

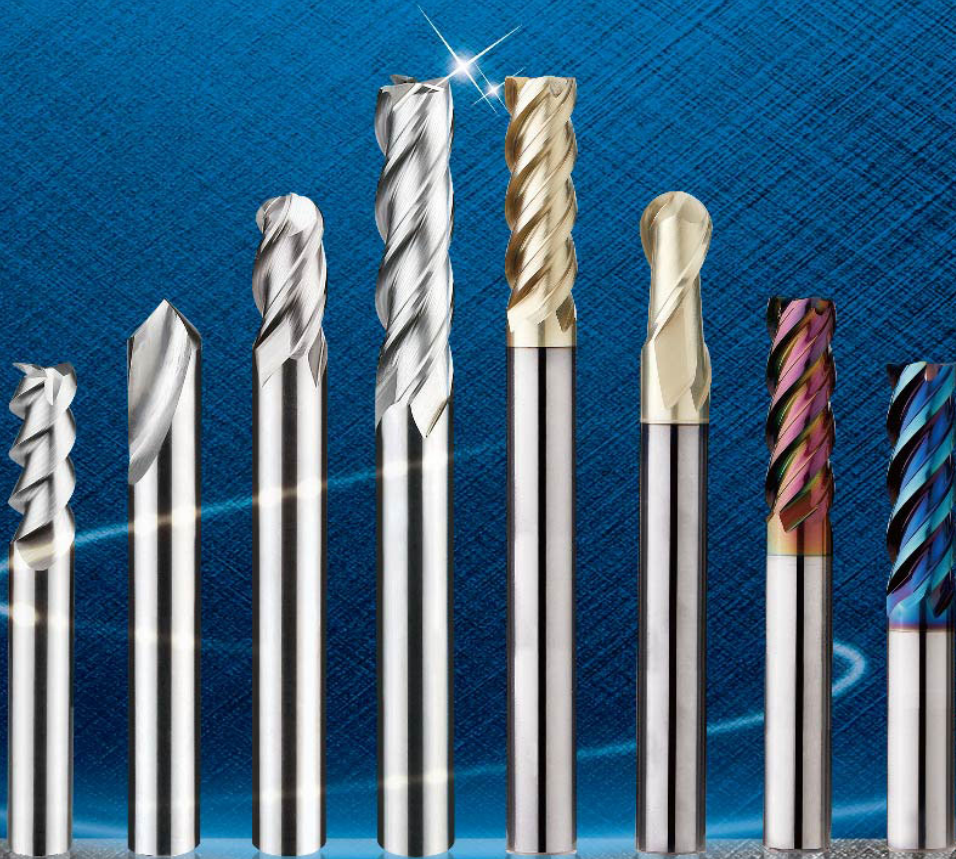

**MSC**

精密工具

PRECISION TOOLS





## 標準長系列

	<b>GCA</b> 2刃超微粒立銼刀 2 Flutes Micro Grain End Mills
P3	
	<b>GC</b> 2刃超微粒立銼刀 2 Flutes Micro Grain End Mills
P4	
	<b>GCA</b> 4刃超微粒立銼刀 4 Flutes Micro Grain End Mills
P5	
	<b>GC</b> 4刃超微粒立銼刀 4 Flutes Micro Grain End Mills
P6	
	<b>FGA</b> 4刃超微粒立銼刀 4 Flutes Micro Grain End Mills
P7	
	<b>FG</b> 4刃超微粒立銼刀 4 Flutes Micro Grain End Mills
P8	
	<b>FGZ</b> 超微粒立銼刀 Micro Grain End Mills
P9	



## 高速及難切削用系列

	<b>XGA</b> 4刃超微粒立銼刀 4 Flutes Micro Grain End Mills
P10	
	<b>HGA</b> 3刃超微粒高螺旋立銼刀 3 Flutes Micro Grain High Helix End Mills
P11	
	<b>VGA</b> 6刃超微粒高硬度立銼刀 6 Flutes Micro Grain High Hardness End Mills
P12	

## 圓頭系列

	<b>BCA</b> 2刃超微粒圓頭立銼刀 2 Flutes Micro Grain Ball End Mills
P13	
	<b>BC</b> 2刃超微粒圓頭立銼刀 2 Flutes Micro Grain Ball End Mills
P14	
	<b>BCZ</b> 超微粒圓頭立銼刀 Micro Grain Ball End Mills
P15	
	<b>BCA</b> 4刃超微粒圓頭立銼刀 4 Flutes Micro Grain Ball End Mills
P16	
	<b>BC</b> 4刃超微粒圓頭立銼刀 4 Flutes Micro Grain Ball End Mills
P17	



## 圓隅角系列

	<b>RGA</b> 2刃超微粒圓隅立銼刀 2 Flutes Micro Grain End Mills
P18	
	<b>RGA</b> 4刃超微粒圓隅立銼刀 4 Flutes Micro Grain End Mills
P19	

## 標準長柄系列

	<b>LGCA</b> 2刃超微粒長柄立銼刀 2 Flutes Micro Grain Long Shank End Mills
P20	
	<b>LGC</b> 2刃超微粒長柄立銼刀 2 Flutes Micro Grain Long Shank End Mills
P21	
	<b>LGCA</b> 4刃超微粒長柄立銼刀 4 Flutes Micro Grain Long Shank End Mills
P22	
	<b>LGC</b> 4刃超微粒長柄立銼刀 4 Flutes Micro Grain Long Shank End Mills
P23	

## 長柄圓頭系列

	<b>LBCA</b> 2刃超微粒長柄圓頭立銼刀 2 Flutes Micro Grain Long Shank Ball End Mills
P24	
	<b>LBC</b> 2刃超微粒長柄圓頭立銼刀 2 Flutes Micro Grain Long Shank Ball End Mills
P25	
	<b>LBCA</b> 4刃超微粒長柄圓頭立銼刀 4 Flutes Micro Grain Long Shank Ball End Mills
P26	

## 長柄圓隅角系列

	<b>LRGA</b> 2刃超微粒長柄圓隅立銼刀 2 Flutes Micro Grain Long Shank Ball End Mills
P27	
	<b>LRGA</b> 4刃超微粒長柄圓隅立銼刀 4 Flutes Micro Grain Long Shank Ball End Mills
P28	

## 標準長刃系列

	<b>LGFA</b> 2刃超微粒長刃立銼刀 2 Flutes Micro Grain Long Flute End Mills
P29	
	<b>LGF</b> 2刃超微粒長刃立銼刀 2 Flutes Micro Grain Long Flute End Mills
P30	
	<b>LGFA</b> 4刃超微粒長刃立銼刀 4 Flutes Micro Grain Long Flute End Mills
P31	
	<b>LGF</b> 4刃超微粒長刃立銼刀 4 Flutes Micro Grain Long Flute End Mills
P32	
	<b>LFGA</b> 4刃超微粒長刃立銼刀 4 Flutes Micro Grain Long Flute End Mills
P33	
	<b>LFG</b> 4刃超微粒長刃立銼刀 4 Flutes Micro Grain Long Flute End Mills
P34	

長刃高速及難切削系列



**LXGA** 4刃超微粒長刃立銼刀  
4 Flutes Micro Grain Long Flute End Mills

P35



**LVGA** 6刃超微粒長刃高硬度立銼刀  
6 Flutes Micro Grain Long High Hardness End Mills

P36

深溝圓頭系列



**LBHA** 4刃超微粒深溝圓頭立銼刀  
4 Flutes Micro Grain Taper End Mills

P37-38

斜度系列



**TGA** 2刃超微粒斜度立銼刀  
2 Flutes Micro Grain Taper End Mills

P39-40

鋁用系列



**AEC** 3刃超微粒鋁用立銼刀  
3 Flutes Micro Grain End Mills

P41

粗齒系列



**GCAE** 4刃超微粒粗齒立銼刀  
4 Flutes Micro Grain Roughing End Mill

P42

定位鑽系列



**WPA** 超微粒定位鑽  
Micro Grain Orientate Drill

P43



**LWPA** 長柄超微粒定位鑽  
Micro Grain Long Shank Orientate Drill

P43



**WP** 超微粒定位鑽  
Micro Grain Orientate Drill

P44



**LWP** 長柄超微粒定位鑽  
Micro Grain Long Shank Orientate Drill

P44

定位鑽系列



**WDA** 4刃超微粒鑽頭  
4 Flutes Micro Grain Coated Drill

P45

極超微粒系列



**UGA** 2刃極超微粒立銼刀  
2 Flutes Super Micro Grain End Mills

P46



**UGA** 4刃極超微粒立銼刀  
4 Flutes Super Micro Grain End Mills

P47



**UFA** 極超微粒立銼刀  
Super Micro Grain End Mills

P48



**UFZ** 極超微粒立銼刀  
Super Micro Grain End Mills

P49



**UFB** 極超微粒立銼刀  
Super Micro Grain End Mills

P50



**UFT** 極超微粒立銼刀  
Super Micro Grain End Mills

P51



**UMGA** 2刃極超微粒微小徑立銼刀  
3 Flutes Super Micro Diameter End Mills

P52



**UVA** 6刃極超微粒高硬度專用立銼刀  
6 Flutes Super Micro Grain High Hardness End Mills

P53



**UBA** 2刃極超微粒圓頭立銼刀  
2 Flutes Super Micro Grain Ball End Mills

P54



**UBZ** 極超微粒圓頭立銼刀  
Super Micro Grain Ball End Mills

P55



**UBB** 極超微粒圓頭立銼刀  
Super Micro Grain Ball End Mills

P56



**URA** 2刃極超微粒圓頭立銼刀  
2 Flutes Super Micro Grain End Mills

P57

焊刀鎢鋼刀具系列



P58



焊刀鎢鋼刀具系列  
Milling Cutter Series

捨棄式刀具系列



捨棄式銼刀具系列  
Disposable Milling Cutter Series



P64

捨棄式車刀具系列  
Disposable Lathe Cutter Series



## 捨棄式刀具系列

-  P65 直角端銑刀  
Shoulder Endmill
-  P66 快削型端銑刀  
High Speed Endmill
-  P67 快削型端銑刀  
High Speed Endmill
-  P67 R角端銑刀  
Radius Endmill
-  P68 快削型平面銑刀  
Face Milling Cutter
-  P68 直角平面銑刀  
Face Milling Cutter
-  P69 CRS型R角平面銑刀  
Face Milling Cutter
-  P69 CRP 型R角平面銑刀  
Face Milling Cutter
-  P70 球形精銑刀  
Ball-Nose Endmill
-  P71 固定式雙刃粗搪刀  
Twin-blade Boring Bar
-  P71 粗重切削筒型銑刀  
Rotgh Milling Cutter
-  P72 高進給切削端銑刀  
High Speed Endmill
-  P72 45度倒角刀  
Chamfering Endmill
-  P73 螺絲頭沉孔銑刀  
Bolt Countersink Endmill
-  P73 T型槽端銑刀  
T-slot Endmill
-  P74 45度高速平面殼型銑刀  
Milling Cutter
-  P74 45度高速殼型銑刀  
Milling Cutter
-  P75 直角平面銑刀  
Shoulder Face Milling Cutter
-  P75 千鳥型側銑刀  
Sidemilling Cutter

## 捨棄式刀具系列

-  P76 T型側銑刀  
T Type Sidemilling Cutter
-  P76 75度平面銑刀  
75° Milling Cutter
-  P77 65度平面銑刀  
65° Face Milling Cutter
-  P78 45度平面銑刀  
45° Face Milling Cutter
-  P79 一體式圓刀刃銑刀  
X-POWER Radius Milling Cutter
-  P80 替換式銑刀  
Radius Corner Modular Endmill
-  P80 快削型平面銑刀  
High-speed Rough Endmill
-  P81 快速型端銑刀  
High Speed Rough Endmill
-  P82 RD型R角端銑刀  
Conner Radius Endmill
-  P82 捨棄快速沈頭用柱孔刀
-  P83 快速鑽2倍長  
Super Power Drill 2d
-  P83 多功能捨棄內外倒角刀
-  P84 快速鑽3倍長  
Super Power Drill 3d
-  P85 快速鑽4倍長  
Super Power Drill 4d
-  P86 快速型端銑刀  
High Speed Roungh Endmill
-  P86 快速型平面銑刀  
High Speed Roungh Face Endmill Cutter

## 機械刀桿系列

-  P87 SDC 後拉式精密刀把
-  P88 SDC 後拉式刀把

機械刀桿系列

-  SK 高精度刀把  
P89
-  SK 筒夾  
P90
-  ER 銑刀夾頭  
P91
-  ER 筒夾  
P94
-  ER 螺帽  
P95
-  扳手  
P96
-  SLA 側固式刀把  
P98
-  SLP 側固式刀把  
P101
-  SLB 側固式刀把  
P101
-  SLA 超短型側固式刀把  
P102
-  DCM 強力型刀把  
P103
-  直筒夾  
P104
-  FMA 平面銑刀把  
P105
-  FMB 平面銑刀把  
P107

量具系列

-  LR-20 光電式尋邊器  
P109
-  MITUTOYO 游標卡尺  
P110
-  Z 軸設定器  
P112

絲攻系列

-  PM 粉末螺旋絲攻  
P113
-  多用途環帶先端絲攻  
P114

超鈷鋼系列

-  超鈷鋼標準立銑刀-2刃型  
P122

超鈷鋼粗銑刀系列

-  超鈷鋼粗銑刀  
P125

鎢鋼鑽頭系列

-  鎢鋼鑽頭  
P126

超鈷鋼鑽頭系列

-  SG-ESS DRILLS 粉末短鑽  
P127

鎢鋼直柄機械絞刀

-  鎢鋼直柄機械絞刀  
P136

超鈷鋼倒角刀系列

-  HSSCo8 90° 單刃倒角刀  
P138

機械配件系列

-  AMS-160AH 強力型工件定位器  
P140



## ● Guide Lines to Icons

<b>鎢鋼材質 Carbide</b>				<b>鍍層 Coating</b>			
UMG S580 Super Micro Grain. 超微粒子		MG M340 Micro Grain. 超微粒子		<b>TiAlN</b> Generally used on all kind of machining with benefits of long tool life. 一般切削加工用，壽命長。		<b>Z3</b> Generally used on all kind of machining with benefits of long tool long life. 一般切削加工用，壽命超長。	
				<b>nAcOB</b> High hardness machining and long life 高硬度加工壽命長		<b>T2</b> Long non-ferrous metal processing life 非鐵金屬加工壽命長	
<b>刃數 Flute</b>				<b>螺旋角 Hilix Angle</b>			
2 Flutes		3 Flutes		4 Flutes		6 Flutes	
				30°		35°	
				45°		55°	
				30°			

## ● OK 被覆 Featheriness

被削材 Wood was cut 外徑 Outside diameter (mm)	普通鋼，合金鋼 Ordinary steel. Alloy Steel						不鏽鋼 Stainless Steel (SUS302. 304)		鑄鐵 Cast Iron (FCD60)		硬質鋁合金 Hard Alloy (AC8A. AC9A)	
	(HRC30未滿 HRC30 Under)		(HRC30~45)		(HRC45~55)		迴轉數 Rotary Few (rpm)	進給 Feed-in (mm/min)	迴轉數 Rotary Few (rpm)	進給 Feed-in (mm/min)	迴轉數 Rotary Few (rpm)	進給 Feed-in (mm/min)
	迴轉數 Rotary Few (rpm)	進給 Feed-in (mm/min)	迴轉數 Rotary Few (rpm)	進給 Feed-in (mm/min)	迴轉數 Rotary Few (rpm)	進給 Feed-in (mm/min)						
1	36000	170	31500	95	15900	40	28500	140	43500	230	28500	230
2	18000	180	15900	100	7950	40	14250	150	21750	240	14250	240
4	9000	210	7950	120	3975	50	7200	175	10800	280	7200	280
6	6000	235	5250	135	2700	55	4800	190	7200	320	4800	320
8	4500	260	3975	150	1950	60	3600	220	5400	350	3600	350
10	3600	280	3150	160	1575	70	2850	230	4350	380	2850	380
16	2250	315	1950	180	990	75	1800	260	2700	420	1800	420
20	1800	305	1575	175	795	70	1425	250	2100	410	1425	410

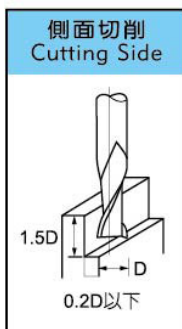
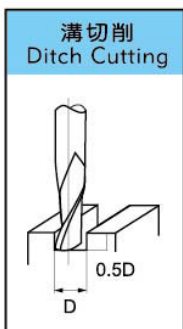

- 註1) 4刃刀請以上表所列 1.4~1.6倍之進給使用。  
 註2) 進刀深度超越左述時，請將進給降低20%~30%。  
 註3) OK被覆品可提升上列迴轉數與進給50%。  
 註4) 請使用鋼性強、精度高之機械與夾具。  
 註5) 請選用適合被削材之切削油。

- 1) 4 bladed knife to the above listed in Table 1.4 to 1.6 times the use of feed.  
 2) Feed in depth beyond the left when you feed reduced by 20% to 30%.  
 3) OK lining materials can enhance the number of the above rotary feed 50%.  
 4) Please use the steel strong, with high precision mechanical fixture.  
 5) Please be selected for cutting wood cutting oil.

## ● Guide Lines to Icons

### 被切削材硬度 Work Material Hardness



Work material hardness in up to HRC30°, HRC45°, HRC60°, HRC65°。  
被切削材質硬度在 HRC30°, HRC45°, HRC60°, HRC65°。

### 夾角 Angle



### 圓隅角 Corner R



### 角度 Angle



偏心圓弧離隙角 Angle of Eccentric Radius Relief.  
斜線切面離隙角 Angle of Slant Tangent Relief.  
大斜線切面離隙角 Angle of Big Slant Tangent Relief.

## ● OK 被覆 Featheriness

被削材 Wood was cut 外徑 Outside diameter (mm)	普通鋼，合金鋼 Ordinary steel, Alloy Steel						不鏽鋼 Stainless Steel (SUS302, 304)		鑄鐵 Cast Iron (FCD60)		硬質鋁合金 Hard Alloy (AC8A, AC9A)	
	(HRC30未滿 HRC30 Under)		(HRC30~45)		(HRC45~55)		迴轉數 Rotary Few (rpm)	進給 Feed-in (mm/min)	迴轉數 Rotary Few (rpm)	進給 Feed-in (mm/min)	迴轉數 Rotary Few (rpm)	進給 Feed-in (mm/min)
	迴轉數 Rotary Few (rpm)	進給 Feed-in (mm/min)	迴轉數 Rotary Few (rpm)	進給 Feed-in (mm/min)	迴轉數 Rotary Few (rpm)	進給 Feed-in (mm/min)						
1	36000	170	31500	95	15900	40	28500	140	43500	230	28500	230
2	18000	180	15900	100	7950	40	14250	150	21750	240	14250	240
4	9000	210	7950	120	3975	50	7200	175	10800	280	7200	280
6	6000	235	5250	135	2700	55	4800	190	7200	320	4800	320
8	4500	260	3975	150	1950	60	3600	220	5400	350	3600	350
10	3600	280	3150	160	1575	70	2850	230	4350	380	2850	380
16	2250	315	1950	180	990	75	1800	260	2700	420	1800	420
20	1800	305	1575	175	795	70	1425	250	2100	410	1425	410

	粗切削 Rough cut	加工 Dressing	
進刀 深度 Feed dep (t)	<0.3D	0.1 ~ 0.3mm	
進給 Feed in (p)	<0.7D	<0.1D	

- 註1) 4刃刀請以上表所列 1.4~1.6倍之進給使用。  
註2) 進刀深度超越左述時，請將進給降低20%~30%。  
註3) OK被覆品可提升上列迴轉數與進給50%。  
註4) 請使用鋼性強、精度高之機械與夾具。  
註5) 請選用適合被削材之切削油。

- 1) 4 bladed knife to the above listed in Table 1.4 to 1.6 times the use of feed.  
2) Feed in depth beyond the left when you feed reduced by 20% to 30%.  
3) OK lining materials can enhance the number of the above rotary feed 50%.  
4) Please use the steel strong, with high precision mechanical fixture.  
5) Please be selected for cutting wood cutting oil.



● **超微粒立銑刀 Micro Grain End Mills**

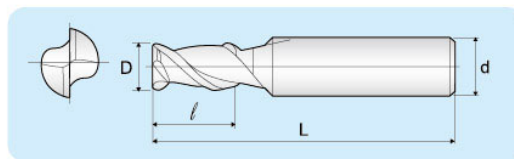

2刃 2 Flutes



標準長系列

**產品特色**

刀刃區近於鏡面，刃口表面光滑，排屑順暢，刀具壽命長，精度也提高。

**FEATURES**

Generally used on wide range of every kind machining. With benefits of fracture resistance and strong edge. Coated TiAlN for maximum heat and wear resistance. Provide maximum hardness and fracture resistance.

適用性	被削鋼材	WORK MATERIAL
★★★	鋼、碳鋼	Steel, Carbon steel S15C
★★★	鋼、碳鋼	Steel, Carbon steel S45C
★★	鋼、碳鋼	Hardened Steel, Carbon steel S45C 硬化處理
★	鋼、碳鋼	Hardened Steel, Carbon steel S75C
★★★	鋼、碳鋼	Hardened Steel, Carbon steel S75C 硬化處理
★★★	低合金鋼	Low allow steel SCM, SNCM
★	低合金鋼	Hardened SCM, SNCM 硬化處理
	低合金鋼	Hardened SCM, SNCM 硬化處理
	低合金鋼	Hardened SCM, SNCM 硬化處理
★★	高合金鋼	High allow steel SKD, SKT, SKH
	高合金鋼	Hardened SKD, SKT, SKH 硬化處理
★	不銹鋼	Stainless steel SUS403
★	不銹鋼	Stainless steel SUS403
★	不銹鋼	Stainless steel SUS304, SUS316
★★★	鑄鐵	Cast iron
★	球墨鑄鐵	Nodular cast iron
	難削材料	Exotic material 耐熱合金、超合金
★	鋁	Aluminum
★	鋁合金	Aluminum alloy

★★★ 極佳 ★★ 佳 ★ 尚可

型號 Type No	直徑 (D) Diameter	刃長 (l) Flute Length	全長 (L) O. A. L.	柄徑 (d) Shank Dta	牌價 Price
GCA0101042	1.0	2.5	50	4	370
GCA0151042	1.5	4.0	50	4	370
GCA0201042	2.0	5.0	50	4	370
GCA0251042	2.5	6.5	50	4	370
GCA0301042	3.0	7.5	50	4	370
GCA0351042	3.5	9.0	50	4	370
GCA0401042	4.0	10.0	50	4	370
GCA0451062	4.5	11.5	50	6	420
GCA0501062	5.0	12.5	50	6	420
GCA0551062	5.5	14.0	50	6	420
GCA0601062	6.0	15.0	50	6	420
GCA0652082	6.5	16.5	60	8	840
GCA0702082	7.0	17.5	60	8	840
GCA0752082	7.5	19.0	60	8	840
GCA0802082	8.0	20.0	60	8	840
GCA0853102	8.5	21.5	75	10	1300
GCA0903102	9.0	22.5	75	10	1300
GCA0953102	9.5	24.0	75	10	1300
GCA1003102	10.0	25.0	75	10	1300
GCA1053122	10.5	26.5	75	12	1750
GCA1103122	11.0	27.5	75	12	1750
GCA1153122	11.5	29.0	75	12	1750
GCA1203122	12.0	30.0	75	12	1750
GCA1304162	13.0	32.5	100	16	4080
GCA1404162	14.0	35.0	100	16	4080
GCA1504162	15.0	37.5	100	16	4450
GCA1604162	16.0	40.0	100	16	4450
GCA1804202	18.0	45.0	100	20	6200
GCA2004202	20.0	50.0	100	20	6200

Unit : mm

3 ※ 本牌價依市場行情依於折扣優惠，歡迎查詢價格  
The discount will be offered based on current prices. Welcome to check the prices.

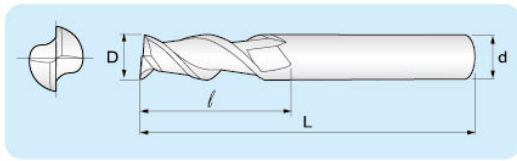

2刃 2 Flutes

● 超微粒立銑刀 Micro Grain End Mills

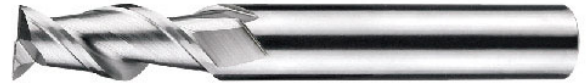

型號 Type No	直徑 (D) Diameter	刃長 (L) Flute Length	全長 (L) O. A. L.	柄徑 (d) Shank Dia.	牌價 Price
GC0101042	1.0	2.5	50	4	335
GC0151042	1.5	4.0	50	4	335
GC0201042	2.0	5.0	50	4	335
GC0251042	2.5	6.5	50	4	335
GC0301042	3.0	7.5	50	4	335
GC0351042	3.5	9.0	50	4	335
GC0401042	4.0	10.0	50	4	335
GC0451062	4.5	11.5	50	6	380
GC0501062	5.0	12.5	50	6	380
GC0551062	5.5	14.0	50	6	380
GC0601062	6.0	15.0	50	6	380
GC0652082	6.5	16.5	60	8	760
GC0702082	7.0	17.5	60	8	760
GC0752082	7.5	19.0	60	8	760
GC0802082	8.0	20.0	60	8	760
GC0853102	8.5	21.5	75	10	1170
GC0903102	9.0	22.5	75	10	1170
GC0953102	9.5	24.0	75	10	1170
GC1003102	10.0	25.0	75	10	1170
GC1053122	10.5	26.5	75	12	1575
GC1103122	11.0	27.5	75	12	1575
GC1153122	11.5	29.0	75	12	1575
GC1203122	12.0	30.0	75	12	1575
GC1304162	13.0	32.5	100	16	3675
GC1404162	14.0	35.0	100	16	3675
GC1504162	15.0	37.5	100	16	4005
GC1604162	16.0	40.0	100	16	4005
GC1804202	18.0	45.0	100	20	5580
GC2004202	20.0	50.0	100	20	5580

Unit : mm

產品特色

刀刃區近於鏡面，刃口表面光滑，排屑順暢，刀具壽命長，精度也提高。

FEATURES

Generally used on wide range of every kind machining. With enefits of fracture resistance and strong edge.

適用性	被削鋼材	WORK MATERIAL
★★★	鋼、碳鋼	Steel, Carbon steel S15C
★★	鋼、碳鋼	Steel, Carbon steel S45C
★	鋼、碳鋼	Hardened S45C 硬化處理
	鋼、碳鋼	Steel, Carbon steel S75C
	鋼、碳鋼	Hardened S75C 硬化處理
★★	低合金鋼	Low allow steel SCM, SNCM
	低合金鋼	Hardened SCM, SNCM 硬化處理
	低合金鋼	Hardened SCM, SNCM 硬化處理
	低合金鋼	Hardened SCM, SNCM 硬化處理
★	高合金鋼	High allow steel SKD, SKT, SKH
	高合金鋼	Hardened SKD, SKT, SKH 硬化處理
	不銹鋼	Stainless steel SUS403
	不銹鋼	Stainless steel SUS403
	不銹鋼	Stainless steel SUS304, SUS316
★★★	鑄鐵	Cast iron
★	球墨鑄鐵	Nodular cast iron
	難削材料	Exotic material 耐熱合金、超合金
★	鋁	Aluminium
★	鋁合金	Aluminium alloy

★★★ 極佳 ★★ 佳 ★ 尚可

※ 本牌價依市場行情依於折扣優惠，歡迎查詢價格  
The discount will be offered based on current prices. Welcome to check the prices.



● **超微粒立銑刀 Micro Grain End Mills**

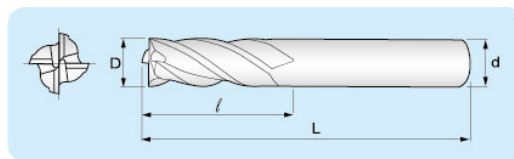

4刃 4 Flutes



標準長系列  
STANDARD SERIES

**產品特色**

刀刃區近於鏡面，刃口表面光滑，排屑順暢，刀具壽命長，精度也提高。

**FEATURES**

Generally used on wide range of every kind machining. With benefits of fracture resistance and strong edge. Coated TiAlN for maximum heat and wear resistance. Provide maximum hardness and fracture resistance.

適用性	被削鋼材	WORK MATERIAL
★★★	鋼、碳鋼	Steel, Carbon steel S15C
★★★	鋼、碳鋼	Steel, Carbon steel S45C
★★	鋼、碳鋼	Hardened Steel, Carbon steel S45C 硬化處理
★	鋼、碳鋼	Steel, Carbon steel S75C
★★	鋼、碳鋼	Hardened Steel S75C 硬化處理
★★★	低合金鋼	Low alloy steel SCM, SNCM
★	低合金鋼	Hardened SCM, SNCM 硬化處理
★★	低合金鋼	Hardened SCM, SNCM 硬化處理
★★	低合金鋼	Hardened SCM, SNCM 硬化處理
★★	高合金鋼	High alloy steel SKD, SKT, SKH
★★	高合金鋼	Hardened SKD, SKT, SKH 硬化處理
★	不銹鋼	Stainless steel SUS403
★	不銹鋼	Stainless steel SUS403
★	不銹鋼	Stainless steel SUS304, SUS316
★★★	鑄鐵	Cast iron
★	球墨鑄鐵	Nodular cast iron
★	難削材料	Exotic material 耐熱合金、超合金
★	鋁	Aluminum
★	鋁合金	Aluminum alloy

★★★ 極佳 ★★ 佳 ★ 尚可

型號 Type No	直徑 (D) Diameter	刃長 (ℓ) Flute Length	全長 (L) O. A. L.	柄徑 (d) Shank Dia.	牌價 Price
GCA0101044	1.0	2.5	50	4	370
GCA0151044	1.5	4.0	50	4	370
GCA0201044	2.0	5.0	50	4	370
GCA0251044	2.5	6.5	50	4	370
GCA0301044	3.0	7.5	50	4	370
GCA0351044	3.5	9.0	50	4	370
GCA0401044	4.0	10.0	50	4	370
GCA0451064	4.5	11.5	50	6	420
GCA0501064	5.0	12.5	50	6	420
GCA0551064	5.5	14.0	50	6	420
GCA0601064	6.0	15.0	50	6	420
GCA0652084	6.5	16.5	60	8	840
GCA0702084	7.0	17.5	60	8	840
GCA0752084	7.5	19.0	60	8	840
GCA0802084	8.0	20.0	60	8	840
GCA0853104	8.5	21.5	75	10	1300
GCA0903104	9.0	22.5	75	10	1300
GCA0953104	9.5	24.0	75	10	1300
GCA1003104	10.0	25.0	75	10	1300
GCA1053124	10.5	26.5	75	12	1750
GCA1103124	11.0	27.5	75	12	1750
GCA1153124	11.5	29.0	75	12	1750
GCA1203124	12.0	30.0	75	12	1750
GCA1304164	13.0	32.5	100	16	4080
GCA1404164	14.0	35.0	100	16	4080
GCA1504164	15.0	37.5	100	16	4450
GCA1604164	16.0	40.0	100	16	4450
GCA1804204	18.0	45.0	100	20	6200
GCA2004204	20.0	50.0	100	20	6200

Unit : mm

5 ※ 本牌價依市場行情依於折扣優惠，歡迎查詢價格  
The discount will be offered based on current prices. Welcome to check the prices.

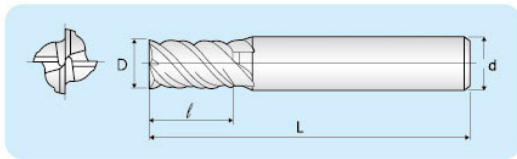

4刃 4 Flutes

● 超微粒立銑刀 Micro Grain End Mills



型號 Type No	直徑 (D) Diameter	刃長 (ℓ) Flute Length	全長 (L) O. A. L.	柄徑 (d) Shank Dia.	牌價 Price
GC0101044	1.0	2.5	50	4	335
GC0151044	1.5	4.0	50	4	335
GC0201044	2.0	5.0	50	4	335
GC0251044	2.5	6.5	50	4	335
GC0301044	3.0	7.5	50	4	335
GC0351044	3.5	9.0	50	4	335
GC0401044	4.0	10.0	50	4	335
GC0451064	4.5	11.5	50	6	380
GC0501064	5.0	12.5	50	6	380
GC0551064	5.5	14.0	50	6	380
GC0601064	6.0	15.0	50	6	380
GC0652084	6.5	16.5	60	8	760
GC0702084	7.0	17.5	60	8	760
GC0752084	7.5	19.0	60	8	760
GC0802084	8.0	20.0	60	8	760
GC0853104	8.5	21.5	75	10	1170
GC0903104	9.0	22.5	75	10	1170
GC0953104	9.5	24.0	75	10	1170
GC1003104	10.0	25.0	75	10	1170
GC1053124	10.5	26.5	75	12	1575
GC1103124	11.0	27.5	75	12	1575
GC1153124	11.5	29.0	75	12	1575
GC1203124	12.0	30.0	75	12	1575
GC1304164	13.0	32.5	100	16	3675
GC1404164	14.0	35.0	100	16	3675
GC1504164	15.0	37.5	100	16	4005
GC1604164	16.0	40.0	100	16	4005
GC1804204	18.0	45.0	100	20	5580
GC2004204	20.0	50.0	100	20	5580

Unit : mm

產品特色

刀刃區近於鏡面，刃口表面光滑，排屑順暢，刀具壽命長，精度也提高。

FEATURES

Generally used on wide range of every kind machining. With enefits of fracture resistance and strong edge.

適用性	被削鋼材	WORK MATERIAL
★★★	鋼、碳鋼	Steel, Carbon steel S15C
★★	鋼、碳鋼	Steel, Carbon steel S45C
★	鋼、碳鋼	Hardened S45C 硬化處理
	鋼、碳鋼	Steel, Carbon steel S75C
	鋼、碳鋼	Hardened S75C 硬化處理
★★	低合金鋼	Low allow steel SCM, SNCM
	低合金鋼	Hardened SCM, SNCM 硬化處理
	低合金鋼	Hardened SCM, SNCM 硬化處理
	低合金鋼	Hardened SCM, SNCM 硬化處理
★	高合金鋼	High allow steel SKD, SKT, SKH
	高合金鋼	Hardened SKD, SKT, SKH 硬化處理
	不銹鋼	Stainless steel SUS403
	不銹鋼	Stainless steel SUS403
	不銹鋼	Stainless steel SUS304, SUS316
★★★	鑄鐵	Cast iron
★	球墨鑄鐵	Nodular cast iron
	難削材料	Exotic material 耐熱合金、超合金
★	鋁	Aluminum
★	鋁合金	Aluminum alloy

★★★ 極佳 ★★ 佳 ★ 尚可

※ 本牌價依市場行情依於折扣優惠，歡迎查詢價格  
The discount will be offered based on current prices. Welcome to check the prices.



● **超微粒立銑刀 Micro Grain End Mills**

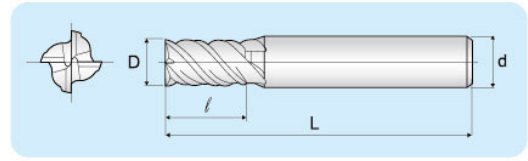

4刃 4 Flutes



標準長系列

**產品特色**

螺旋角為45度，切削阻力小，高效能加工，可應用不鏽鋼、高合金鋼、調質鋼、熱處理鋼及難切削材，性能完全發揮。

**FEATURES**

Helix angle 45°, less cutting drag, more effective working, best for working on stainless steel, high alloy steel, harden steel, and difficult - machine materials. Coated TiAlN for maximum heat and wear resistance provide maximum hardness and fracture resistance.

適用性	被削鋼材	WORK MATERIAL
★★★	鋼、碳鋼	Steel, Carbon steel S15C
★★★	鋼、碳鋼	Steel, Carbon steel S45C
★★	鋼、碳鋼	Hardened S45C 硬化處理
★★	鋼、碳鋼	Steel, Carbon steel S75C
★	鋼、碳鋼	Hardened S75C 硬化處理
★★★	低合金鋼	Low alloy steel SCM, SNCM
★★	低合金鋼	Hardened SCM, SNCM 硬化處理
★	低合金鋼	Hardened SCM, SNCM 硬化處理
★	低合金鋼	Hardened SCM, SNCM 硬化處理
★★★	高合金鋼	High alloy steel SKD, SKT, SKH
★★	高合金鋼	Hardened SKD, SKT, SKH 硬化處理
★★★	不鏽鋼	Stainless steel SUS403
★★★	不鏽鋼	Stainless steel SUS403
★★★	不鏽鋼	Stainless steel SUS304, SUS316
★★	鑄鐵	Cast iron
★★	球墨鑄鐵	Nodular cast iron
★	難削材料	Exotic material 耐熱合金、超合金
★	鋁	Aluminum
★	鋁合金	Aluminum alloy

★★★ 極佳 ★★ 佳 ★ 尚可

型號 Type No	直徑 (D) Diameter	刃長 (ℓ) Flute Length	全長 (L) O. A. L.	柄徑 (d) Shank Dia.	牌價 Price
FGA0101044	1.0	3.0	50	4	450
FGA0151044	1.5	4.5	50	4	450
FGA0201044	2.0	6.0	50	4	450
FGA0251044	2.5	7.5	50	4	450
FGA0301044	3.0	9.0	50	4	450
FGA0351044	3.5	10.5	50	4	450
FGA0401044	4.0	12.0	50	4	450
FGA0451064	4.5	13.5	50	6	510
FGA0501064	5.0	15.0	50	6	510
FGA0551064	5.5	16.5	50	6	510
FGA0601064	6.0	18.0	50	6	510
FGA0652084	6.5	19.5	60	8	1010
FGA0702084	7.0	21.0	60	8	1010
FGA0752084	7.5	22.5	60	8	1010
FGA0802084	8.0	24.0	60	8	1010
FGA0853104	8.5	25.5	75	10	1560
FGA0903104	9.0	27.0	75	10	1560
FGA0953104	9.5	28.5	75	10	1560
FGA1003104	10.0	30.0	75	10	1560
FGA1053124	10.5	31.5	75	12	2100
FGA1103124	11.0	33.0	75	12	2100
FGA1153124	11.5	34.5	75	12	2100
FGA1203124	12.0	36.0	75	12	2100
FGA1304164	13.0	39.0	100	16	5340
FGA1404164	14.0	42.0	100	16	5340
FGA1504164	15.0	45.0	100	16	5340
FGA1604164	16.0	48.0	100	16	5340
FGA1804204	18.0	50.0	100	20	7440
FGA2004204	20.0	50.0	100	20	7440

Unit : mm

7 ※ 本牌價依市場行情依於折扣優惠，歡迎查詢價格  
The discount will be offered based on current prices. Welcome to check the prices.

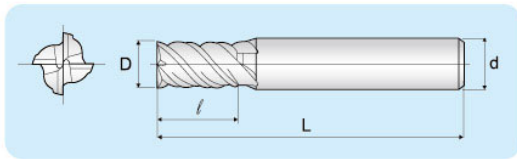

4刃 4 Flutes

● 超微粒立銑刀 Micro Grain End Mills

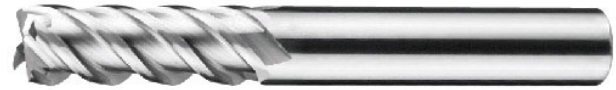

型號 Type No	直徑 (D) Diameter	刃長 (ℓ) Flute Length	全長 (L) O. A. L.	柄徑 (d) Shank Dia.	牌價 Price
FG0101044	1.0	3.0	50	4	410
FG0151044	1.5	4.5	50	4	410
FG0201044	2.0	6.0	50	4	410
FG0251044	2.5	7.5	50	4	410
FG0301044	3.0	9.0	50	4	410
FG0351044	3.5	10.5	50	4	410
FG0401044	4.0	12.0	50	4	410
FG0451064	4.5	13.5	50	4	460
FG0501064	5.0	15.0	50	6	460
FG0551064	5.5	16.5	50	6	460
FG0601064	6.0	18.0	50	6	460
FG0652084	6.5	19.5	50	6	920
FG0702084	7.0	21.0	60	8	920
FG0752084	7.5	22.5	60	8	920
FG0802084	8.0	24.0	60	8	920
FG0853104	8.5	25.5	60	10	1410
FG0903104	9.0	27.0	75	10	1410
FG0953104	9.5	28.5	75	10	1410
FG1003104	10.0	30.0	75	10	1410
FG1053124	10.5	31.5	75	12	1890
FG1103124	11.0	33.0	75	12	1890
FG1153124	11.5	34.5	75	12	1890
FG1203124	12.0	36.0	75	12	1890
FG1304164	13.0	39.0	75	16	4810
FG1404164	14.0	42.0	100	16	4810
FG1504164	15.0	45.0	100	16	4810
FG1604164	16.0	48.0	100	16	4810
FG1804204	18.0	50.0	100	20	6700
FG2004204	20.0	50.0	100	20	6700

Unit : mm

產品特色

螺旋角為45度，切削阻力小，高效能加工，可應用不鏽鋼、高合金鋼、調質鋼、熱處理鋼及難切削材，性能完全發揮。

FEATURES

Helix angle 45°, less cutting drag, more effective working, best for working on stainless steel, high alloy steel, harden steel, and difficult-machine materials. Coated TiAlN for maximum heat and wear resistance provide maximum hardness and fracture resistance.

適用性	被削鋼材	WORK MATERIAL
★★★	鋼、碳鋼	Steel, Carbon steel S15C
★★	鋼、碳鋼	Steel, Carbon steel S45C
★	鋼、碳鋼	Hardened S45C 硬化處理
	鋼、碳鋼	Steel, Carbon steel S75C
	鋼、碳鋼	Hardened S75C 硬化處理
★★	低合金鋼	Low alloy steel SCM, SNCM
	低合金鋼	Hardened SCM, SNCM 硬化處理
	低合金鋼	Hardened SCM, SNCM 硬化處理
	低合金鋼	Hardened SCM, SNCM 硬化處理
★	高合金鋼	High alloy steel SKD, SKT, SKH
	高合金鋼	Hardened SKD, SKT, SKH 硬化處理
	不鏽鋼	Stainless steel SUS403
	不鏽鋼	Stainless steel SUS403
	不鏽鋼	Stainless steel SUS304, SUS316
★★★	鑄鐵	Cast iron
	球墨鑄鐵	Nodular cast iron
	難削材料	Exotic material 耐熱合金、超合金
★	鋁	Aluminum
★	鋁合金	Aluminum alloy

★★★ 極佳 ★★ 佳 ★ 尚可

※ 本牌價依市場行情依於折扣優惠，歡迎查詢價格  
The discount will be offered based on current prices. Welcome to check the prices.



● **超微粒立銑刀 Micro Grain End Mills**

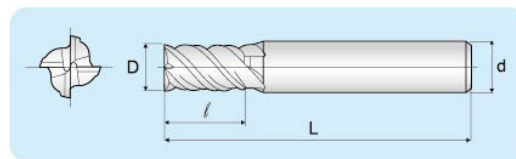

4刃 4 Flutes



**產品特色**

螺旋角為45度，切削阻力小，高效能加工，可應用不鏽鋼、高合金鋼、調質鋼、熱處理鋼及難切削材，性能完全發揮。

**FEATURES**

Helix angle 45°, less cutting drag, more effective working, best for working on stainless steel, high alloy steel, harden steel, and difficult - machine materials. Coated TiAlN for maximum heat and wear resistance provide maximum hardness and fracture resistance.

適用性	被削鋼材	WORK MATERIAL
★★★	鋼、碳鋼	Steel, Carbon steel S15C
★★★	鋼、碳鋼	Steel, Carbon steel S45C
★★	鋼、碳鋼	Hardened S45C 硬化處理
★★	鋼、碳鋼	Steel, Carbon steel S75C
★	鋼、碳鋼	Hardened S75C 硬化處理
★★★	低合金鋼	Low allow steel SCM, SNCM
★★	低合金鋼	Hardened SCM, SNCM 硬化處理
★	低合金鋼	Hardened SCM, SNCM 硬化處理
★	低合金鋼	Hardened SCM, SNCM 硬化處理
★★★	高合金鋼	High allow steel SKD, SKT, SKH
★★	高合金鋼	Hardened SKD, SKT, SKH 硬化處理
★★★	不鏽鋼	Stainless steel SUS403
★★★	不鏽鋼	Stainless steel SUS403
★★★	不鏽鋼	Stainless steel SUS304, SUS316
★★	鑄鐵	Cast iron
★★	球墨鑄鐵	Nodular cast iron
★	難削材料	Exotic material 耐熱合金、超合金
★	鋁	Aluminum
★	鋁合金	Aluminum alloy

★★★ 極佳 ★★ 佳 ★ 尚可

型號 Type No	直徑 (D) Diameter	刃長 (ℓ) Flute Length	全長 (L) O. A. L.	柄徑 (d) Shank Dia.	牌價 Price
FGZ 0101044	1.0	3.0	50	4	450
FGZ 0151044	1.5	4.5	50	4	450
FGZ 0201044	2.0	6.0	50	4	450
FGZ 0251044	2.5	7.5	50	4	450
FGZ 0301044	3.0	9.0	50	4	450
FGZ 0351044	3.5	10.5	50	4	450
FGZ 0401044	4.0	12.0	50	4	450
FGZ 0451064	4.5	13.5	50	6	510
FGZ 0501064	5.0	15.0	50	6	510
FGZ 0551064	5.5	16.5	50	6	510
FGZ 0601064	6.0	18.0	50	6	510
FGZ 0652084	6.5	19.5	60	8	1010
FGZ 0702084	7.0	21.0	60	8	1010
FGZ 0752084	7.5	22.5	60	8	1010
FGZ 0802084	8.0	24.0	60	8	1010
FGZ 0853104	8.5	25.5	75	10	1560
FGZ 0903104	9.0	27.0	75	10	1560
FGZ 0953104	9.5	28.5	75	10	1560
FGZ 1003104	10.0	30.0	75	10	1560
FGZ 1053124	10.5	31.5	75	12	2100
FGZ 1103124	11.0	33.0	75	12	2100
FGZ 1153124	11.5	34.5	75	12	2100
FGZ 1203124	12.0	36.0	75	12	2100
FGZ 1304164	13.0	39.0	100	16	5340
FGZ 1404164	14.0	42.0	100	16	5340
FGZ 1504164	15.0	45.0	100	16	5340
FGZ 1604164	16.0	48.0	100	16	5340
FGZ 1804204	18.0	50.0	100	20	7440
FGZ 2004204	20.0	50.0	100	20	7440

Unit : mm

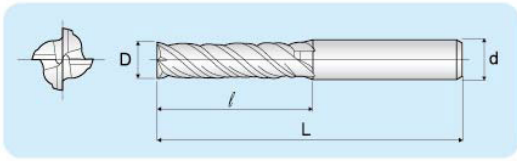

4刃 4 Flutes

● 超微粒立銑刀 Micro Grain End Mills



型號 Type No	直徑 (D) Diameter	刃長 (ℓ) Flute Length	全長 (L) O. A. L.	柄徑 (d) Shank Dia.	牌價 Price
XGA0101044	1.0	2.5	50	4	450
XGA0151044	1.5	4.0	50	4	450
XGA0201044	2.0	5.0	50	4	450
XGA0251044	2.5	6.5	50	4	450
XGA0301044	3.0	7.5	50	4	450
XGA0351044	3.5	9.0	50	4	450
XGA0401044	4.0	10.0	50	4	450
XGA0451064	4.5	11.5	50	6	510
XGA0501064	5.0	12.5	50	6	510
XGA0551064	5.5	14.0	50	6	510
XGA0601064	6.0	15.0	50	6	510
XGA0652084	6.5	16.5	60	8	1010
XGA0702084	7.0	17.5	60	8	1010
XGA0752084	7.5	19.0	60	8	1010
XGA0802084	8.0	20.0	60	8	1010
XGA0853104	8.5	21.5	75	10	1560
XGA0903104	9.0	22.5	75	10	1560
XGA0953104	9.5	24.0	75	10	1560
XGA1003104	10.0	25.0	75	10	1560
XGA1053124	10.5	26.5	75	12	2100
XGA1103124	11.0	27.5	75	12	2100
XGA1153124	11.5	29.0	75	12	2100
XGA1203124	12.0	30.0	75	12	2100
XGA1304164	13.0	32.5	100	16	5340
XGA1404164	14.0	35.0	100	16	5340
XGA1504164	15.0	37.5	100	16	5340
XGA1604164	16.0	40.0	100	16	5340
XGA1804204	18.0	45.0	100	20	7440
XGA2004204	20.0	50.0	100	20	7440

Unit : mm

產品特色

螺旋角為45度，切削阻力小，高效能加工，可應用不銹鋼、高合金鋼、調質鋼、熱處理鋼及難切削材，性能完全發揮。

FEATURES

Helix angle 45°, less cutting drag, more effective working, best for working on stainless steel, high alloy steel, harden steel, and difficult - machine materials. Coated TiAlN for maximum heat and wear resistance provide maximum hardness and fracture resistance.

適用性	被削鋼材	WORK MATERIAL
★★★	鋼、碳鋼	Steel, Carbon steel S15C
★★★	鋼、碳鋼	Steel, Carbon steel S45C
★★	鋼、碳鋼	Hardened S45C 硬化處理
★★	鋼、碳鋼	Steel, Carbon steel S75C
★	鋼、碳鋼	Hardened S75C 硬化處理
★★★	低合金鋼	Low alloy steel SCM, SNCM
★★	低合金鋼	Hardened SCM, SNCM 硬化處理
★	低合金鋼	Hardened SCM, SNCM 硬化處理
★	低合金鋼	Hardened SCM, SNCM 硬化處理
★★★	高合金鋼	High alloy steel SKD, SKT, SKH
★	高合金鋼	Hardened SKD, SKT, SKH 硬化處理
★★★	不銹鋼	Stainless steel SUS403
★★★	不銹鋼	Stainless steel SUS403
★★★	不銹鋼	Stainless steel SUS304, SUS316
★★	鑄鐵	Cast iron
★★	球墨鑄鐵	Nodular cast iron
★	難削材料	Exotic material 耐熱合金、超合金
★	鋁	Aluminum
★	鋁合金	Aluminum alloy

★★★ 極佳 ★★ 佳 ★ 尚可

※ 本牌價依市場行情依於折扣優惠，歡迎查詢價格  
The discount will be offered based on current prices. Welcome to check the prices.



● **超微粒高螺旋立銑刀**  
Micro Grain High Helix End Mills

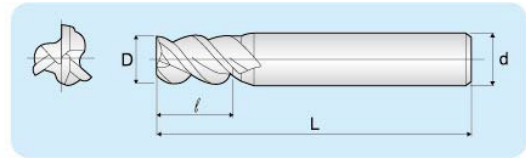

3刃 3 Flutes



型號 Type No	直徑 (D) Diameter	刃長 (ℓ) Flute Length	全長 (L) O. A. L.	柄徑 (d) Shank Dia.	牌價 Price
HGA0101043	1	2.5	50	4	445
HGA0201043	2	5.0	50	4	445
HGA0301043	3	7.5	50	4	445
HGA0401043	4	10.0	50	4	445
HGA0501063	5	12.5	50	6	505
HGA0601063	6	15.0	50	6	505
HGA0702083	7	17.5	60	8	1010
HGA0802083	8	20.0	60	8	1010
HGA0903103	9	22.5	75	10	1560
HGA1003103	10	25.0	75	10	1560
HGA1103123	11	27.5	75	12	2100
HGA1203123	12	30.0	75	12	2100
HGA1604163	16	40.0	100	16	5340

Unit : mm

**產品特色**

螺旋角為45度，切削阻力小，高效能加工，可應用不鏽鋼、高合金鋼、調質鋼、熱處理鋼及難切削材，性能完全發揮。

**FEATURES**

Helix angle 45°, less cutting drag, more effective working, best for working on stainless steel, high alloy steel, harden steel, and difficult-machine materials. Coated TiAlN for maximum heat and wear resistance provide maximum hardness and fracture resistance.

適用性	被削鋼材	WORK MATERIAL
★★★★	鋼、碳鋼	Steel, Carbon steel S15C
★★★★	鋼、碳鋼	Steel, Carbon steel S45C
★★★	鋼、碳鋼	Hardened S45C 硬化處理
★★★	鋼、碳鋼	Steel, Carbon steel S75C
★	鋼、碳鋼	Hardened S75C 硬化處理
★★★★	低合金鋼	Low allow steel SCM, SNCM
★★	低合金鋼	Hardened SCM, SNCM 硬化處理
★	低合金鋼	Hardened SCM, SNCM 硬化處理
★	低合金鋼	Hardened SCM, SNCM 硬化處理
★★★★	高合金鋼	High allow steel SKD, SKT, SKH
★	高合金鋼	Hardened SKD, SKT, SKH 硬化處理
★★★★	不鏽鋼	Stainless steel SUS403
★★★★	不鏽鋼	Stainless steel SUS403
★★★★	不鏽鋼	Stainless steel SUS304, SUS316
★★★	鑄鐵	Cast iron
★★	球墨鑄鐵	Nodular cast iron
★	難削材料	Exotic material 耐熱合金、超合金
★	鋁	Aluminum
★	鋁合金	Aluminum alloy

★★★★ 極佳 ★★★ 佳 ★ 尚可

高速及難切削系列

HIGH SPEED AND DIFFICULT TO CUT SERIES

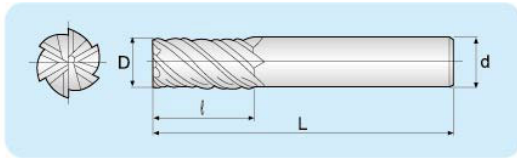

6刃 6 Flutes

## ● 超微粒高硬度立銑刀 Micro Grain High Hardness End Mills



型號 Type No	直徑(D) Diameter	刃長(L) Flute Length	全長(L) O. A. L.	柄徑(d) Shank Dia.	牌價 Price
VGA0301046	3	7.5	50	4	500
VGA0401046	4	10.0	50	4	500
VGA0501066	5	12.5	50	6	570
VGA0601066	6	15.0	50	6	570
VGA0802086	8	20.0	60	8	1135
VGA1003106	10	25.0	75	10	1755
VGA1203126	12	30.0	75	12	2365
VGA1604166	16	40.0	100	16	6010
VGA2004206	20	50.0	100	20	8370
VGA2506256	25	65.0	150	25	28000

Unit : mm

### 產品特色

1. 高硬度加工用，針對熱處理鋼材 HRC60 以上，性能完全發揮。
2. 刀刃區近於鏡面，刃口表面光滑，排屑順暢，刀具壽命長，精度也提高。
3. 使用高速切削，可得到非常光滑的表面。

### FEATURES

Exceptionally strong which improve surface finishes and high feed rates. Coated TiAlN for maximum heat and wear resistance provide maximum hardness and fracture resistance.

適用性	被削鋼材	WORK MATERIAL
★★★	鋼、碳鋼	Steel, Carbon steel S15C
★★★	鋼、碳鋼	Steel, Carbon steel S45C
★★	鋼、碳鋼	Hardened S45C 硬化處理
★★	鋼、碳鋼	Hardened S75C 硬化處理
★★	鋼、碳鋼	Hardened S75C 硬化處理
★★★	低合金鋼	Low allow steel SCM, SNCM
★★	低合金鋼	Hardened SCM, SNCM 硬化處理
★	低合金鋼	Hardened SCM, SNCM 硬化處理
★	低合金鋼	Hardened SCM, SNCM 硬化處理
★★★	高合金鋼	High allow steel SKD, SKT, SKH
★	高合金鋼	Hardened SKD, SKT, SKH 硬化處理
★★	不銹鋼	Stainless steel SUS403
★★	不銹鋼	Stainless steel SUS403
★★	不銹鋼	Stainless steel SUS304, SUS316
★★	鑄鐵	Cast iron
★★	球墨鑄鐵	Nodular cast iron
★★★	難削材料	Exotic material 耐熱合金、超合金
★	鋁	Aluminum
★	鋁合金	Aluminum alloy

★★★ 極佳 ★★ 佳 ★ 尚可



**● 超微粒圓頭立銑刀**  
Micro Grain Ball End Mills

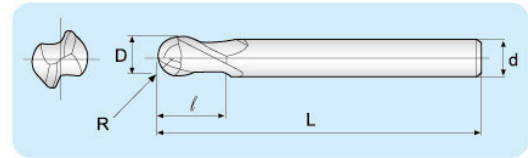

2刃 2 Flutes



型號 Type No	直徑 (D) Diameter	刃長 (ℓ) Flute Length	全長 (L) O. A. L.	柄徑 (d) Shank Dia.	牌價 Price
BCA0101042	0.5 R	2	50	4	480
BCA0151042	0.75 R	3	50	4	480
BCA0201042	1 R	4	50	4	480
BCA0251042	1.25 R	5	50	4	480
BCA0301042	1.5 R	6	50	4	480
BCA0351042	1.75 R	7	50	4	480
BCA0401042	2 R	8	50	4	480
BCA0451062	2.25 R	9	50	6	525
BCA0501062	2.5 R	10	50	6	525
BCA0551062	2.75 R	11	50	6	525
BCA0601062	3 R	12	50	6	525
BCA0652082	3.25 R	13	60	8	950
BCA0702082	3.5 R	14	60	8	950
BCA0752082	3.75 R	15	60	8	950
BCA0802082	4 R	16	60	8	950
BCA0903102	4.5 R	18	75	10	1400
BCA1003102	5 R	20	75	10	1400
BCA1103122	5.5 R	22	75	12	1850
BCA1203122	6 R	24	75	12	1850
BCA1404162	7 R	28	100	16	6000
BCA1604162	8 R	32	100	16	6000
BCA18041202	9 R	36	100	20	8000
BCA2004202	10 R	40	100	20	8000
BCA2505252	12.5 R	50	150	25	-

Unit : mm

**產品特色**

刀刃區近於鏡面，刃口表面光滑，排屑順暢，刀具壽命長，精度也提高。

**FEATURES**

Generally used on wide range of every kind machining. With benefits of fracture resistance and strong edge. Coated TiAlN for maximum heat and wear resistance. Provide maximum hardness and fracture resistance.

適用性	被削鋼材	WORK MATERIAL
★★★	鋼、碳鋼	Steel, Carbon steel S15C
★★★	鋼、碳鋼	Steel, Carbon steel S45C
★★	鋼、碳鋼	Hardened S45C 硬化處理
★	鋼、碳鋼	Steel, Carbon steel S75C
	鋼、碳鋼	Hardened S75C 硬化處理
★★★	低合金鋼	Low allow steel SCM, SNCM
★	低合金鋼	Hardened SCM, SNCM 硬化處理
	低合金鋼	Hardened SCM, SNCM 硬化處理
	低合金鋼	Hardened SCM, SNCM 硬化處理
★★	高合金鋼	High allow steel SKD, SKT, SKH
	高合金鋼	Hardened SKD, SKT, SKH 硬化處理
★	不銹鋼	Stainless steel SUS403
★	不銹鋼	Stainless steel SUS403
★	不銹鋼	Stainless steel SUS304, SUS316
★★★	鑄鐵	Cast iron
★	球墨鑄鐵	Nodular cast iron
	難削材料	Exotic material 耐熱合金、超合金
★	鋁	Aluminum
★	鋁合金	Aluminum alloy

★★★ 極佳 ★★ 佳 ★ 尚可

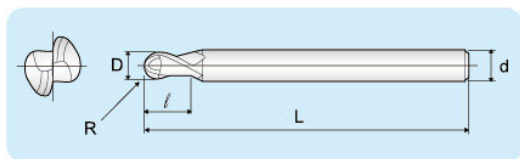

2刃 2 Flutes

## ● 超微粒圓頭立銑刀 Micro Grain Ball End Mills



型號 Type No	直徑 (D) Diameter	刃長 (ℓ) Flute Length	全長 (L) O. A. L.	柄徑 (d) Shank Dia.	牌價 Price
BC0101042	0.5 R	2	50	4	435
BC0151042	0.75 R	3	50	4	435
BC0201042	1.0 R	4	50	4	435
BC0251042	1.25 R	5	50	4	435
BC0301042	1.5 R	6	50	4	435
BC0351042	1.75 R	7	50	4	435
BC0401042	2.0 R	8	50	4	435
BC0451062	2.25 R	9	50	6	475
BC0501062	2.5 R	10	50	6	475
BC0551062	2.75 R	11	50	6	475
BC0601062	3.0 R	12	50	6	475
BC0652082	3.25 R	13	60	8	855
BC0702082	3.5 R	14	60	8	855
BC0752082	3.75 R	15	60	8	855
BC0802082	4.0 R	16	60	8	855
BC0903102	4.5 R	18	75	10	1260
BC1003102	5.0 R	20	75	10	1260
BC1103122	5.5 R	22	75	12	1665
BC1203122	6.0 R	24	75	12	1665
BC1404162	7.0 R	28	100	16	5400
BC1604162	8.0 R	32	100	16	5400
BC1804202	9.0 R	36	100	20	7200
BC2004202	10.0 R	40	100	20	7200
BC2505252	12.5 R	50	150	25	-

Unit : mm

### 產品特色

刀刃區近於鏡面，刃口表面光滑，排屑順暢，刀具壽命長，精度也提高。

### FEATURES

Generally used on wide range of every kind machining. With benefits of fracture resistance and strong edge.

適用性	被削鋼材	WORK MATERIAL
★★★	鋼、碳鋼	Steel, Carbon steel S15C
★★	鋼、碳鋼	Steel, Carbon steel S45C
★	鋼、碳鋼	Hardened S45C 硬化處理
★★	鋼、碳鋼	Steel, Carbon steel S75C
	鋼、碳鋼	Hardened S75C 硬化處理
★★	低合金鋼	Low allow steel SCM, SNCM
	低合金鋼	Hardened SCM, SNCM 硬化處理
	低合金鋼	Hardened SCM, SNCM 硬化處理
	低合金鋼	Hardened SCM, SNCM 硬化處理
★	高合金鋼	High allow steel SKD, SKT, SKH
	高合金鋼	Hardened SKD, SKT, SKH 硬化處理
	不銹鋼	Stainless steel SUS403
	不銹鋼	Stainless steel SUS403
	不銹鋼	Stainless steel SUS304, SUS316
★★★	鑄鐵	Cast iron
★	球墨鑄鐵	Nodular cast iron
	難削材料	Exotic material 耐熱合金、超合金
★	鋁	Aluminum
★	鋁合金	Aluminum alloy

★★★ 極佳 ★★ 佳 ★ 尚可

※ 本牌價依市場行情依於折扣優惠，歡迎查詢價格  
The discount will be offered based on current prices. Welcome to check the prices.

## ● 超微粒圓頭立銑刀 Micro Grain Ball End Mills

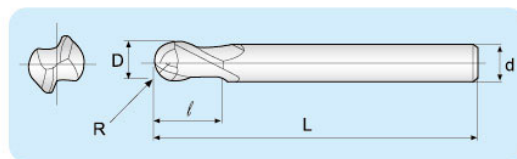
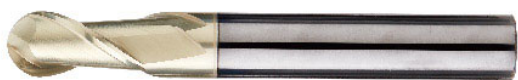

2刃 2 Flutes



### 產品特色

刀刃區近於鏡面，刃口表面光滑，排屑順暢，刀具壽命長，精度也提高。

### FEATURES

Generally used on wide range of every kind machining. With benefits of fracture resistance and strong edge. Coated TiAlN for maximum heat and wear resistance. Provide maximum hardness and fracture resistance.

型號 Type No	直徑 (D) Diameter	刃長 (ℓ) Flute Length	全長 (L) O. A. L.	柄徑 (d) Shank Dia.	牌價 Price
BCZ0101042	0.5 R	2	50	4	480
BCZ0151042	0.75 R	3	50	4	480
BCZ0201042	1 R	4	50	4	480
BCZ0251042	1.25 R	5	50	4	480
BCZ0301042	1.5 R	6	50	4	480
BCZ0351042	1.75 R	7	50	4	480
BCZ0401042	2 R	8	50	4	480
BCZ0451062	2.25 R	9	50	6	525
BCZ0501062	2.5 R	10	50	6	525
BCZ0551062	2.75 R	11	50	6	525
BCZ0601062	3 R	12	50	6	525
BCZ0652082	3.25 R	13	60	8	950
BCZ0702082	3.5 R	14	60	8	950
BCZ0752082	3.75 R	15	60	8	950
BCZ0802082	4 R	16	60	8	950
BCZ0903102	4.5 R	18	75	10	1400
BCZ1003102	5 R	20	75	10	1400
BCZ1103122	5.5 R	22	75	12	1850
BCZ1203122	6 R	24	75	12	1850
BCZ1404162	7 R	28	100	16	6000
BCZ1604162	8 R	32	100	16	6000
BCZ18041202	9 R	36	100	20	8000
BCZ2004202	10 R	40	100	20	8000
BCZ2505252	12.5 R	50	150	25	-

Unit : mm

適用性	被削鋼材	WORK MATERIAL
★★★	鋼、碳鋼	Steel, Carbon steel S15C
★★★	鋼、碳鋼	Steel, Carbon steel S45C
★★	鋼、碳鋼	Hardened S45C 硬化處理
★	鋼、碳鋼	Steel, Carbon steel S75C
	鋼、碳鋼	Hardened S75C 硬化處理
★★★	低合金鋼	Low alloy steel SCM, SNCM
★	低合金鋼	Hardened SCM, SNCM 硬化處理
	低合金鋼	Hardened SCM, SNCM 硬化處理
	低合金鋼	Hardened SCM, SNCM 硬化處理
★★	高合金鋼	High alloy steel SKD, SKT, SKH
	高合金鋼	Hardened SKD, SKT, SKH 硬化處理
★	不銹鋼	Stainless steel SUS403
★	不銹鋼	Stainless steel SUS403
★	不銹鋼	Stainless steel SUS304, SUS316
★★★	鑄鐵	Cast iron
★	球墨鑄鐵	Nodular cast iron
	難削材料	Exotic material 耐熱合金、超合金
★	鋁	Aluminum
★	鋁合金	Aluminum alloy

★★★ 極佳 ★★ 佳 ★ 尚可

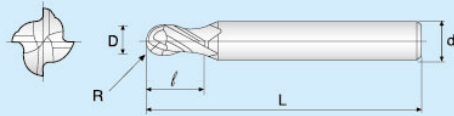

4刃 4 Flutes

● 超微粒圓頭立銑刀  
Micro Grain Ball End Mills



型號 Type No	直徑 (D) Diameter	刃長 (ℓ) Flute Length	全長 (L) O. A. L.	柄徑 (d) Shank Dia.	牌價 Price
BCA0101044	0.5 R	2	50	4	540
BCA0151044	0.75 R	3	50	4	540
BCA0201044	1.0 R	4	50	4	540
BCA0251044	1.25 R	5	50	4	540
BCA0301044	1.5 R	6	50	4	540
BCA0351044	1.75 R	7	50	4	540
BCA0401044	2.0 R	8	50	4	540
BCA0451064	2.25 R	9	50	6	600
BCA0501064	2.5 R	10	50	6	600
BCA0551064	2.75 R	11	50	6	600
BCA0601064	3.0 R	12	50	6	600
BCA0652084	3.25 R	13	60	8	1075
BCA0702084	3.5 R	14	60	8	1075
BCA0752084	3.75 R	15	60	8	1075
BCA0802084	4.0 R	16	60	8	1075
BCA0903104	4.5 R	18	75	10	1575
BCA1003104	5.0 R	20	75	10	1575
BCA1103124	5.5 R	22	75	12	2085
BCA1203124	6.0 R	24	75	12	2085
BCA1404164	7.0 R	28	100	16	6750
BCA1604164	8.0 R	32	100	16	6750
BCA1804204	9.0 R	36	100	20	9000
BCA2004204	10.0 R	40	100	20	9000
BCA2505254	12.5 R	50	150	25	-

Unit : mm

產品特色

刀刃區近於鏡面，刃口表面光滑，排屑順暢，刀具壽命長，精度也提高。

FEATURES

Generally used on wide range of every kind machining. With benefits of fracture resistance and strong edge. Coated TiAlN for maximum heat and wear resistance. Provide maximum hardness and fracture resistance.

適用性	被削鋼材	WORK MATERIAL
★★★★	鋼、碳鋼	Steel, Carbon steel S15C
★★★★	鋼、碳鋼	Steel, Carbon steel S45C
★★	鋼、碳鋼	Hardened S45C 硬化處理
★	鋼、碳鋼	Steel, Carbon steel S75C
	鋼、碳鋼	Hardened S75C 硬化處理
★★★★	低合金鋼	Low alloy steel SCM, SNCM
★	低合金鋼	Hardened SCM, SNCM 硬化處理
	低合金鋼	Hardened SCM, SNCM 硬化處理
★	低合金鋼	Hardened SCM, SNCM 硬化處理
★★	高合金鋼	High alloy steel SKD, SKT, SKH
	高合金鋼	Hardened SKD, SKT, SKH 硬化處理
★	不銹鋼	Stainless steel SUS403
★	不銹鋼	Stainless steel SUS403
★	不銹鋼	Stainless steel SUS304, SUS316
★★★★	鑄鐵	Cast iron
★	球墨鑄鐵	Nodular cast iron
	難削材料	Exotic material 耐熱合金、超合金
★	鋁	Aluminum
★	鋁合金	Aluminum alloy

★★★★ 極佳 ★★ 佳 ★ 尚可

※本牌價依市場行情依於折扣優惠，歡迎查詢價格  
The discount will be offered based on current prices. Welcome to check the prices.



● **超微粒圓頭立銑刀**  
Micro Grain Ball End Mills

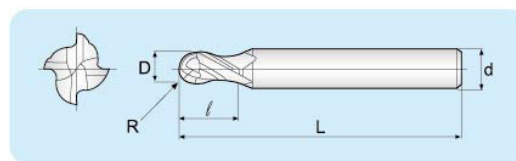

4刃 4 Flutes

圓頭系列  
BALL END SERIES

**產品特色**

刀刃區近於鏡面，刃口表面光滑，排屑順暢，刀具壽命長，精度也提高。

**FEATURES**

Generally used on wide range of every kind machining. With benefits of fracture resistance and strong edge. Coated TiAlN for maximum heat and wear resistance. Provide maximum hardness and fracture resistance.

適用性	被削鋼材	WORK MATERIAL
★★★	鋼、碳鋼	Steel, Carbon steel S15C
★★	鋼、碳鋼	Steel, Carbon steel S45C
★	鋼、碳鋼	Hardened S45C 硬化處理
	鋼、碳鋼	Steel, Carbon steel S75C
	鋼、碳鋼	Hardened S75C 硬化處理
★★	低合金鋼	Low allow steel SCM, SNCM
	低合金鋼	Hardened SCM, SNCM 硬化處理
	低合金鋼	Hardened SCM, SNCM 硬化處理
	低合金鋼	Hardened SCM, SNCM 硬化處理
★	高合金鋼	High allow steel SKD, SKT, SKH
	高合金鋼	Hardened SKD, SKT, SKH 硬化處理
	不銹鋼	Stainless steel SUS403
	不銹鋼	Stainless steel SUS403
	不銹鋼	Stainless steel SUS304, SUS316
★★★	鑄鐵	Cast iron
★	球墨鑄鐵	Nodular cast iron
	難削材料	Exotic material 耐熱合金、超合金
★	鋁	Aluminum
★	鋁合金	Aluminum alloy

★★★ 極佳 ★★ 佳 ★ 尚可



型號 Type No	直徑 (D) Diameter	刃長 (ℓ) Flute Length	全長 (L) O. A. L.	柄徑 (d) Shank Dia.	牌價 Price
BC0101044	0.5 R	2	50	4	490
BC0151044	0.75 R	3	50	4	490
BC0201044	1.0 R	4	50	4	490
BC0251044	1.25 R	5	50	4	490
BC0301044	1.5 R	6	50	4	490
BC0351044	1.75 R	7	50	4	490
BC0401044	2.0 R	8	50	4	490
BC0451064	2.25 R	9	50	6	540
BC0501064	2.5 R	10	50	6	540
BC0551064	2.75 R	11	50	6	540
BC0601064	3.0 R	12	50	6	540
BC0652084	3.25 R	13	60	8	970
BC0702084	3.5 R	14	60	8	970
BC0752084	3.75 R	15	60	8	970
BC0802084	4.0 R	16	60	8	970
BC0903104	4.5 R	18	75	10	1420
BC1003104	5.0 R	20	75	10	1420
BC1103124	5.5 R	22	75	12	1880
BC1203124	6.0 R	24	75	12	1880
BC1404164	7.0 R	28	100	16	6070
BC1604164	8.0 R	32	100	16	6070
BC1804204	9.0 R	36	100	20	8100
BC2004204	10.0 R	40	100	20	8100
BC2505254	12.5 R	50	150	25	-

Unit : mm

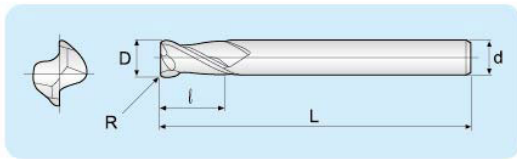

2刃 2 Flutes

● 超微粒圓隅角立銑刀  
Micro Grain Corner Radius End Mills



型號 Type No	直徑 (D) Diameter	刃長 (L) Flute Length	R角 (D) Corner R	全長 (L) O. A. L.	柄徑 (d) Shank Dia.	牌價 Price
RGA03051032	3	6	0.5	50	3	480
RGA03101032	3	6	1.0	50	3	480
RGA04051042	4	8	0.5	50	4	480
RGA04101042	4	8	1.0	50	4	480
RGA06051062	6	12	0.5	50	6	525
RGA06101062	6	12	1.0	50	6	525
RGA06151062	6	12	1.5	50	6	525
RGA06201062	6	12	2.0	50	6	525
RGA08052082	8	16	0.5	60	8	950
RGA08102082	8	16	1.0	60	8	950
RGA08152082	8	16	1.5	60	8	950
RGA08202082	8	16	2.0	60	8	950
RGA08252082	8	16	2.5	60	8	950
RGA08302082	8	16	3.0	60	8	950
RGA10053102	10	20	0.5	75	10	1400
RGA10103102	10	20	1.0	75	10	1400
RGA10153102	10	20	1.5	75	10	1400
RGA10203102	10	20	2.0	75	10	1400
RGA10253102	10	20	2.5	75	10	1400
RGA10303102	10	20	3.0	75	10	1400
RGA12053122	12	24	0.5	75	12	1850
RGA12103122	12	24	1.0	75	12	1850
RGA12153122	12	24	1.5	75	12	1850
RGA12203122	12	24	2.0	75	12	1850
RGA12253122	12	24	2.5	75	12	1850
RGA12303122	12	24	3.0	75	12	1850

Unit : mm

產品特色

1. 使用圓隅角立銑刀可提高進給速率，一次加工完成，增加生產效能降低成本。
2. 圓隅角的設計比一般立銑刀更耐磨耗，延長刀具壽命。
3. 應用於模具加工，適用於一般鋼材、難切削材質，如不銹鋼、鋁合金、調質鋼、NAK55、NAK80、高合金鋼等。

FEATURES

The corner radius design strengthens the end mill by reducing chipping, providing longer tool life. Corner more material faster, improve productivity and reduce cost.

適用性	被削鋼材	WORK MATERIAL
★★	鋼、碳鋼	Steel, Carbon steel S15C
★★★	鋼、碳鋼	Steel, Carbon steel S45C
★★	鋼、碳鋼	Hardened S45C 硬化處理
★	鋼、碳鋼	Steel, Carbon steel S75C
	鋼、碳鋼	Hardened S75C 硬化處理
★★★	低合金鋼	Low allow steel SCM, SNCM
★	低合金鋼	Hardened SCM, SNCM 硬化處理
	低合金鋼	Hardened SCM, SNCM 硬化處理
	低合金鋼	Hardened SCM, SNCM 硬化處理
★★	高合金鋼	High allow steel SKD, SKT, SKH
	高合金鋼	Hardened SKD, SKT, SKH 硬化處理
★	不銹鋼	Stainless steel SUS403
★	不銹鋼	Stainless steel SUS403
★	不銹鋼	Stainless steel SUS304, SUS316
★★★	鑄鐵	Cast iron
★	球墨鑄鐵	Nodular cast iron
	難削材料	Exotic material 耐熱合金、超合金
★	鋁	Aluminum
★	鋁合金	Aluminum alloy

★★★ 極佳 ★★ 佳 ★ 尚可



## ● 超微粒圓隅角立銑刀 Micro Grain Corner Radius End Mills

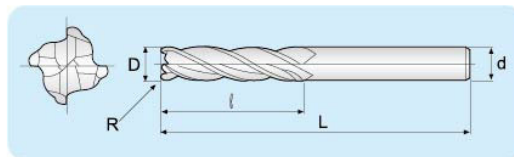

4刃 4 Flutes



### 產品特色

1. 使用圓隅角立銑刀可提高進給速率，一次加工完成，增加生產效能降低成本。
2. 圓隅角的設計比一般立銑刀更耐磨耗，延長刀具壽命。
3. 應用於模具加工，適用於一般鋼材、難切削材質，如不銹鋼、鋁合金、調質鋼、NAK55、NAK80、高合金鋼等。

### FEATURES

The corner radius design strengthens the end mill by reducing chipping, providing longer tool life. Corner more material faster, improve productivity and reduce cost.

適用性	被削鋼材	WORK MATERIAL
★★★	鋼、碳鋼	Steel, Carbon steel S15C
★★★	鋼、碳鋼	Steel, Carbon steel S45C
★★	鋼、碳鋼	Hardened S45C 硬化處理
★	鋼、碳鋼	Steel, Carbon steel S75C
	鋼、碳鋼	Hardened S75C 硬化處理
★★★	低合金鋼	Low allow steel SCM, SNCM
★	低合金鋼	Hardened SCM, SNCM 硬化處理
	低合金鋼	Hardened SCM, SNCM 硬化處理
	低合金鋼	Hardened SCM, SNCM 硬化處理
★★	高合金鋼	High allow steel SKD, SKT, SKH
	高合金鋼	Hardened SKD, SKT, SKH 硬化處理
★	不銹鋼	Stainless steel SUS403
★	不銹鋼	Stainless steel SUS403
★	不銹鋼	Stainless steel SUS304, SUS316
★★★	鑄鐵	Cast iron
★	球墨鑄鐵	Nodular cast iron
	難削材料	Exotic material 耐熱合金、超合金
★	鋁	Aluminum
★	鋁合金	Aluminum alloy

★★★ 極佳 ★★ 佳 ★ 尚可

型號 Type No	直徑 (D) Diameter	刃長 (L) Flute Length	R角 (D) Corner R	全長 (L) O. A. L.	柄徑 (d) Shank Dia.	牌價 Price
RGA03051034	3	6	0.5	50	3	480
RGA03101034	3	6	1.0	50	3	480
RGA04051044	4	8	0.5	50	4	480
RGA04101044	4	8	1.0	50	4	480
RGA06051064	6	12	0.5	50	6	525
RGA06101064	6	12	1.0	50	6	525
RGA06151064	6	12	1.5	50	6	525
RGA06201064	6	12	2.0	60	6	525
RGA08052084	8	16	0.5	60	8	950
RGA08102084	8	16	1.0	60	8	950
RGA08152084	8	16	1.5	60	8	950
RGA08202084	8	16	2.0	60	8	950
RGA08252084	8	16	2.5	60	8	950
RGA08302084	8	16	3.0	60	8	950
RGA10053104	10	20	0.5	75	10	1400
RGA10103104	10	20	1.0	75	10	1400
RGA10153104	10	20	1.5	75	10	1400
RGA10203104	10	20	2.0	75	10	1400
RGA10253104	10	20	2.5	75	10	1400
RGA10303104	10	20	3.0	75	10	1400
RGA12053124	12	24	0.5	75	12	1850
RGA12103124	12	24	1.0	75	12	1850
RGA12153124	12	24	1.5	75	12	1850
RGA12203124	12	24	2.0	75	12	1850
RGA12253124	12	24	2.5	75	12	1850
RGA12303124	12	24	3.0	75	12	1850

Unit : mm

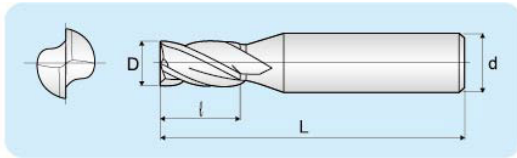

2刃 2 Flutes

● 超微粒長柄立銑刀  
Micro Grain Long Shand End Mills



型號 Type No	直徑 (D) Diameter	刃長 (ℓ) Flute Length	全長 (L) O. A. L.	柄徑 (d) Shank Dia.	牌價 Price
LGCA0303032	3	9	75	3	555
LGCA0403032	4	12	75	4	555
LGCA0604062	6	18	100	6	840
LGCA0605062	6	18	150	6	1260
LGCA0804082	8	24	100	8	1400
LGCA0805082	8	24	150	8	2100
LGCA1004102	10	30	100	10	1850
LGCA1005102	10	30	150	10	2775
LGCA1204122	12	36	100	12	2350
LGCA1205122	12	36	150	12	3450

Unit : mm

產品特色

刀刃區近於鏡面，刃口表面光滑，排屑順暢，刀具壽命長，精度也提高。

FEATURES

Generally used on wide range of every kind machining. With benefits of fracture resistance and strong edge.

適用性	被削鋼材	WORK MATERIAL
★★★★	鋼、碳鋼	Steel, Carbon steel S15C
★★★★	鋼、碳鋼	Steel, Carbon steel S45C
★★	鋼、碳鋼	Hardened S45C 硬化處理
★	鋼、碳鋼	Hardened S75C 硬化處理
★★★★	鋼、碳鋼	Hardened S75C 硬化處理
★★★	低合金鋼	Low allow steel SCM, SNCM
★	低合金鋼	Hardened SCM, SNCM 硬化處理
	低合金鋼	Hardened SCM, SNCM 硬化處理
	低合金鋼	Hardened SCM, SNCM 硬化處理
★★	高合金鋼	High allow steel SKD, SKT, SKH
	高合金鋼	Hardened SKD, SKT, SKH 硬化處理
★	不銹鋼	Stainless steel SUS403
★	不銹鋼	Stainless steel SUS403
★	不銹鋼	Stainless steel SUS304, SUS316
★★★★	鑄鐵	Cast iron
★	球墨鑄鐵	Nodular cast iron
	難削材料	Exotic material 耐熱合金、超合金
★	鋁	Aluminum
★	鋁合金	Aluminum alloy

★★★★ 極佳 ★★ 佳 ★ 尚可

※本牌價依市場行情依於折扣優惠，歡迎查詢價格 20  
The discount will be offered based on current prices. Welcome to check the prices.



● 超微粒長柄立銑刀  
Micro Grain Long Shank End Mills

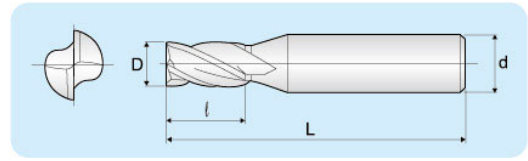

2刃 2 Flutes



型號 Type No	直徑 (D) Diameter	刃長 (ℓ) Flute Length	全長 (L) O. A. L.	柄徑 (d) Shank Dia.	牌價 Price
LGC0303032	3	9	75	3	500
LGC0403042	4	12	75	4	500
LGC0604062	6	18	100	6	760
LGC0605062	6	18	150	6	1135
LGC0804082	8	24	100	8	1260
LGC0805082	8	24	150	8	1890
LGC1004102	10	30	100	10	1665
LGC1005102	10	30	150	10	2070
LGC1204122	12	36	100	12	2500
LGC1205122	12	36	150	12	3105

Unit : mm

產品特色

刀刃區近於鏡面，刃口表面光滑，排屑順暢，刀具壽命長，精度也提高。

FEATURES

Generally used on wide range of every kind machining. With benefits of fracture resistance and strong edge.

標準長柄系列

LONG SHANK SERIES

適用性	被削鋼材	WORK MATERIAL
★★★	鋼、碳鋼	Steel, Carbon steel S15C
★★	鋼、碳鋼	Steel, Carbon steel S45C
★	鋼、碳鋼	Hardened S45C 硬化處理
	鋼、碳鋼	Steel, Carbon steel S75C
	鋼、碳鋼	Hardened S75C 硬化處理
★★	低合金鋼	Low allow steel SCM, SNCM
	低合金鋼	Hardened SCM, SNCM 硬化處理
	低合金鋼	Hardened SCM, SNCM 硬化處理
	低合金鋼	Hardened SCM, SNCM 硬化處理
★	高合金鋼	High allow steel SKD, SKT, SKH
	高合金鋼	Hardened SKD, SKT, SKH 硬化處理
	不銹鋼	Stainless steel SUS403
	不銹鋼	Stainless steel SUS403
	不銹鋼	Stainless steel SUS304, SUS316
★★★	鑄鐵	Cast iron
★	球墨鑄鐵	Nodular cast iron
	難削材料	Exotic material 耐熱合金、超合金
★	鋁	Aluminum
★	鋁合金	Aluminum alloy

★★★ 極佳 ★★ 佳 ★ 尚可

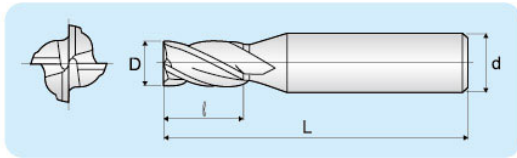

4刃 4 Flutes

## ●超微粒長柄立銑刀 Micro Grain Long Shank End Mills



型號 Type No	直徑 (D) Diameter	刃長 (ℓ) Flute Length	全長 (L) O. A. L.	柄徑 (d) Shank Dia.	牌價 Price
LGCA0303034	3	9	75	3	555
LGCA0403034	4	12	75	4	555
LGCA0604064	6	18	100	6	840
LGCA0605064	6	18	150	6	1260
LGCA0804084	8	24	100	8	1400
LGCA0805084	8	24	150	8	2100
LGCA1004104	10	30	100	10	1850
LGCA1005104	10	30	150	10	2775
LGCA1204124	12	36	100	12	2350
LGCA1205124	12	36	150	12	3450

Unit : mm

### 產品特色

刀刃區近於鏡面，刃口表面光滑，排屑順暢，刀具壽命長，精度也提高。

### FEATURES

Generally used on wide range of every kind machining. With benefits of fracture resistance and strong edge.

適用性	被削鋼材	WORK MATERIAL
★★★	鋼、碳鋼	Steel, Carbon steel S15C
★★★	鋼、碳鋼	Steel, Carbon steel S45C
★★	鋼、碳鋼	Hardened S45C 硬化處理
★	鋼、碳鋼	Hardened S75C 硬化處理
★★★	鋼、碳鋼	Hardened S75C 硬化處理
★★★	低合金鋼	Low allow steel SCM, SNCM
★	低合金鋼	Hardened SCM, SNCM 硬化處理
	低合金鋼	Hardened SCM, SNCM 硬化處理
	低合金鋼	Hardened SCM, SNCM 硬化處理
★★	高合金鋼	High allow steel SKD, SKT, SKH
	高合金鋼	Hardened SKD, SKT, SKH 硬化處理
★	不銹鋼	Stainless steel SUS403
★	不銹鋼	Stainless steel SUS403
★	不銹鋼	Stainless steel SUS304, SUS316
★★★	鑄鐵	Cast iron
★	球墨鑄鐵	Nodular cast iron
	難削材料	Exotic material 耐熱合金、超合金
★	鋁	Aluminum
★	鋁合金	Aluminum alloy

★★★ 極佳 ★★ 佳 ★ 尚可



## ● 超微粒長柄立銑刀 Micro Grain Long Shank End Mills

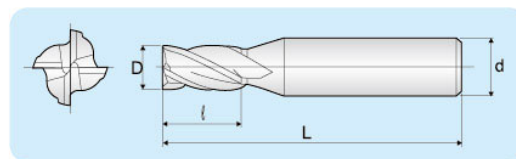

4刃 4 Flutes



型號 Type No	直徑 (D) Diameter	刃長 (L) Flute Length	全長 (L) O. A. L.	柄徑 (d) Shank Dia.	牌價 Price
LGC0303034	3	9	75	3	500
LGC0403044	4	12	75	4	500
LGC0604064	6	18	100	6	760
LGC0605064	6	18	150	6	1135
LGC0804084	8	24	100	8	1260
LGC0805084	8	24	150	8	1890
LGC1004104	10	30	100	10	1665
LGC1005104	10	30	150	10	2070
LGC1204124	12	36	100	12	2500
LGC1205124	12	36	150	12	3105

Unit : mm

### 產品特色

刀刃區近於鏡面，刃口表面光滑，排屑順暢，刀具壽命長，精度也提高。

### FEATURES

Generally used on wide range of every kind machining. With benefits of fracture resistance and strong edge.

標準長柄系列

LONG SHANK SERIES

適用性	被削鋼材	WORK MATERIAL
★★★	鋼、碳鋼	Steel, Carbon steel S15C
★★	鋼、碳鋼	Steel, Carbon steel S45C
★	鋼、碳鋼	Hardened S45C 硬化處理
	鋼、碳鋼	Steel, Carbon steel S75C
	鋼、碳鋼	Hardened S75C 硬化處理
★★	低合金鋼	Low allow steel SCM, SNCM
	低合金鋼	Hardened SCM, SNCM 硬化處理
	低合金鋼	Hardened SCM, SNCM 硬化處理
	低合金鋼	Hardened SCM, SNCM 硬化處理
★	高合金鋼	High allow steel SKD, SKT, SKH
	高合金鋼	Hardened SKD, SKT, SKH 硬化處理
	不銹鋼	Stainless steel SUS403
	不銹鋼	Stainless steel SUS403
	不銹鋼	Stainless steel SUS304, SUS316
★★★	鑄鐵	Cast iron
★	球墨鑄鐵	Nodular cast iron
	難削材料	Exotic material 耐熱合金、超合金
★	鋁	Aluminum
★	鋁合金	Aluminum alloy

★★★ 極佳 ★★ 佳 ★ 尚可

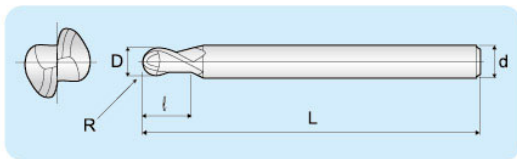

2刃 2 Flutes

● 超微粒長柄圓頭立銑刀  
Micro Grain Long Shank Ball End Mills



型號 Type No	直徑 (D) Diameter	刃長 (ℓ) Flute Length	全長 (L) O. A. L.	柄徑 (d) Shank Dia.	牌價 Price
LBCA0103042	0.5 R	2	75	4	720
LBCA0104042	0.5 R	2	100	4	960
LBCA0153042	0.75 R	3	75	4	720
LBCA0154042	0.75 R	3	100	4	960
LBCA0203042	1 R	4	75	4	720
LBCA0204042	1 R	4	100	4	960
LBCA0253042	1.25 R	5	75	4	720
LBCA0254042	1.25 R	5	100	4	960
LBCA0303042	1.5 R	6	75	4	720
LBCA0304042	1.5 R	6	100	4	960
LBCA0353042	1.75 R	7	75	4	720
LBCA0354042	1.75 R	7	100	4	960
LBCA0403042	2 R	8	75	4	720
LBCA0404042	2 R	8	100	4	960
LBCA0503062	2.5 R	10	75	6	790
LBCA0504062	2.5 R	10	100	6	1050
LBCA0603062	3 R	12	75	6	790
LBCA0604062	3 R	12	100	6	1050
LBCA0804082	4 R	16	100	8	1590
LBCA0805082	4 R	16	150	8	2375
LBCA1004102	5 R	20	100	10	2000
LBCA1005102	5 R	20	150	10	3000
LBCA1204122	6 R	24	100	12	2470
LBCA1205122	6 R	24	150	12	3700
LBCA1605162	8 R	32	150	16	9000
LBCA2005202	10 R	40	150	20	12000

Unit : mm

產品特色

刀刃區近於鏡面，刃口表面光滑，排屑順暢，刀具壽命長，精度也提高。

FEATURES

Generally used on wide range of every kind machining. With benefits of fracture resistance and strong edge. Coated TiAlN for maximum heat and wear resistance. Provide maximum hardness and fracture resistance.

適用性	被削鋼材	WORK MATERIAL
★★★★	鋼、碳鋼	Steel, Carbon steel S15C
★★★★	鋼、碳鋼	Steel, Carbon steel S45C
★★	鋼、碳鋼	Hardened S45C 硬化處理
★	鋼、碳鋼	Steel, Carbon steel S75C
	鋼、碳鋼	Hardened S75C 硬化處理
★★★★	低合金鋼	Low alloy steel SCM, SNCM
★	低合金鋼	Hardened SCM, SNCM 硬化處理
	低合金鋼	Hardened SCM, SNCM 硬化處理
	低合金鋼	Hardened SCM, SNCM 硬化處理
★★	高合金鋼	High alloy steel SKD, SKT, SKH
	高合金鋼	Hardened SKD, SKT, SKH 硬化處理
★	不銹鋼	Stainless steel SUS403
★	不銹鋼	Stainless steel SUS403
★	不銹鋼	Stainless steel SUS304, SUS316
★★★★	鑄鐵	Cast iron
★	球墨鑄鐵	Nodular cast iron
	難削材料	Exotic material 耐熱合金、超合金
★	鋁	Aluminum
★	鋁合金	Aluminum alloy

★★★★ 極佳 ★★ 佳 ★ 尚可

※本牌價依市場行情依於折扣優惠，歡迎查詢價格 24  
The discount will be offered based on current prices. Welcome to check the prices.



## ● 超微粒長柄圓頭立銑刀 Micro Grain Long Shank Ball End Mills

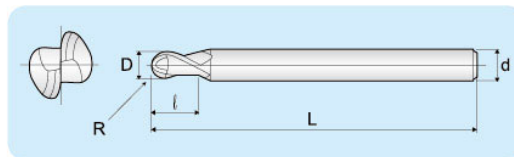

2刃 2 Flutes



**產品特色**

刀刃區近於鏡面，刃口表面光滑，排屑順暢，刀具壽命長，精度也提高。

**FEATURES**

Generally used on wide range of every kind machining. With benefits of fracture resistance and strong edge.

型號 Type No	直徑 (D) Diameter	刃長 (ℓ) Flute Length	全長 (L) O. A. L.	柄徑 (d) Shank Dia.	牌價 Price
LBC0103042	0.5 R	2	75	4	650
LBC0104042	0.5 R	2	100	4	865
LBC0153042	0.75 R	3	75	4	650
LBC0154042	0.75 R	3	100	4	865
LBC0203042	1 R	4	75	4	650
LBC0204042	1 R	4	100	4	865
LBC0253042	1.25R	5	75	4	650
LBC0254042	1.25R	5	100	4	865
LBC0303042	1.5R	6	75	4	650
LBC0304042	1.5R	6	100	4	865
LBC0353042	1.75R	7	75	4	650
LBC0354042	1.75R	7	100	4	865
LBC0403042	2 R	8	75	4	650
LBC0404042	2 R	8	100	4	865
LBC0503062	2.5 R	10	75	6	710
LBC0504062	2.5 R	10	100	6	945
LBC0603062	3 R	12	75	6	710
LBC0604062	3 R	12	100	6	945
LBC0804082	4 R	16	100	8	1425
LBC0805082	4 R	16	150	8	2140
LBC1004102	5 R	20	100	10	1800
LBC1005102	5 R	20	150	10	2700
LBC1204122	6 R	24	100	12	2220
LBC1205122	6 R	24	150	12	3330
LBC1605162	8 R	32	150	16	8100
LBC2005202	10 R	40	150	20	10800

Unit : mm

長柄圓頭系列

LONG SHANK BALL END SERIES

適用性	被削鋼材	WORK MATERIAL
★★★	鋼、碳鋼	Steel, Carbon steel S15C
★★	鋼、碳鋼	Steel, Carbon steel S45C
★	鋼、碳鋼	Hardened S45C 硬化處理
	鋼、碳鋼	Steel, Carbon steel S75C
	鋼、碳鋼	Hardened S75C 硬化處理
★★	低合金鋼	Low allow steel SCM, SNCM
	低合金鋼	Hardened SCM, SNCM 硬化處理
	低合金鋼	Hardened SCM, SNCM 硬化處理
	低合金鋼	Hardened SCM, SNCM 硬化處理
★	高合金鋼	High allow steel SKD, SKT, SKH
	高合金鋼	Hardened SKD, SKT, SKH 硬化處理
	不銹鋼	Stainless steel SUS403
	不銹鋼	Stainless steel SUS403
	不銹鋼	Stainless steel SUS304, SUS316
★★★	鑄鐵	Cast iron
★	球墨鑄鐵	Nodular cast iron
	難削材料	Exotic material 耐熱合金、超合金
★	鋁	Aluminum
★	鋁合金	Aluminum alloy

★★★ 極佳 ★★ 佳 ★ 尚可

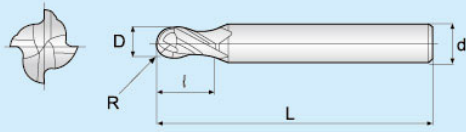

4刃 4 Flutes

● 超微粒長柄圓頭立銑刀  
Micro Long Shank Ball End Mills



型號 Type No	直徑 (D) Diameter	刃長 (ℓ) Flute Length	全長 (L) O. A. L.	柄徑 (d) Shank Dia.	牌價 Price
LBCA0103044	0.5 R	2	75	4	720
LBCA0104044	0.5 R	2	100	4	960
LBCA0153044	0.75 R	3	75	4	720
LBCA0154044	0.75 R	3	100	4	960
LBCA0203044	1 R	4	75	4	720
LBCA0204044	1 R	4	100	4	960
LBCA0253044	1.25 R	5	75	4	720
LBCA0254044	1.25 R	5	100	4	960
LBCA0303044	1.5 R	6	75	4	720
LBCA0304044	1.5 R	6	100	4	960
LBCA0353044	1.75 R	7	75	4	720
LBCA0354044	1.75 R	7	100	4	960
LBCA0403044	2 R	8	75	4	720
LBCA0404044	2 R	8	100	4	960
LBCA0503064	2.5 R	10	75	6	790
LBCA0504064	2.5 R	10	100	6	1050
LBCA0603064	3 R	12	75	6	790
LBCA0604064	3 R	12	100	6	1050
LBCA0804084	4 R	16	100	8	1590
LBCA0805084	4 R	16	150	8	2375
LBCA1004104	5 R	20	100	10	2000
LBCA1005104	5 R	20	150	10	3000
LBCA1204124	6 R	24	100	12	2470
LBCA1205124	6 R	24	150	12	3700
LBCA1605164	8 R	32	150	16	9000
LBCA2005204	10 R	40	150	20	12000

Unit : mm

產品特色

刀刃區近於鏡面，刃口表面光滑，排屑順暢，刀具壽命長，精度也提高。

FEATURES

Generally used on wide range of every kind machining. With benefits of fracture resistance and strong edge. Coated TiAlN for maximum heat and wear resistance. Provide maximum hardness and fracture resistance.

適用性	被削鋼材	WORK MATERIAL
★★★	鋼、碳鋼	Steel, Carbon steel S15C
★★★	鋼、碳鋼	Steel, Carbon steel S45C
★★	鋼、碳鋼	Hardened S45C 硬化處理
★	鋼、碳鋼	Steel, Carbon steel S75C
	鋼、碳鋼	Hardened S75C 硬化處理
★★★	低合金鋼	Low alloy steel SCM, SNCM
★	低合金鋼	Hardened SCM, SNCM 硬化處理
	低合金鋼	Hardened SCM, SNCM 硬化處理
	低合金鋼	Hardened SCM, SNCM 硬化處理
★★	高合金鋼	High alloy steel SKD, SKT, SKH
	高合金鋼	Hardened SKD, SKT, SKH 硬化處理
★	不銹鋼	Stainless steel SUS403
★	不銹鋼	Stainless steel SUS403
★	不銹鋼	Stainless steel SUS304, SUS316
★★★	鑄鐵	Cast iron
★	球墨鑄鐵	Nodular cast iron
	難削材料	Exotic material 耐熱合金、超合金
★	鋁	Aluminum
★	鋁合金	Aluminum alloy

★★★ 極佳 ★★ 佳 ★ 尚可

※本牌價依市場行情依於折扣優惠，歡迎查詢價格  
The discount will be offered based on current prices. Welcome to check the prices.



## ● 超微粒長柄圓隅角立銼刀 Micro Grain Long Corner Radius End Mills

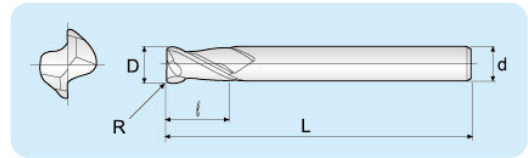

2刃 2 Flutes



長柄圓隅角系列

LONG SHANK CORNER RADIUS END SERIES

### 產品特色

1. 使用圓隅角立銼刀可提高進給速率，一次加工完成，增加生產效能降低成本。
2. 圓隅角的設計比一般立銼刀更耐磨耗，延長刀具壽命。
3. 應用於模具加工，適用於一般鋼材、難切削材質，如不鏽鋼、鎳合金、調質鋼、NAK55、NAK80、高合金鋼等。

### FEATURES

The corner radius design strengthens the end mill by reducing chipping, providing longer tool life. Corner more material faster, improve productivity and reduce cost.

適用性	被削鋼材	WORK MATERIAL
★★★	鋼、碳鋼	Steel, Carbon steel S15C
★★★	鋼、碳鋼	Steel, Carbon steel S45C
★★	鋼、碳鋼	Hardened S45C 硬化處理
★	鋼、碳鋼	Steel, Carbon steel S75C
	鋼、碳鋼	Hardened S75C 硬化處理
★★★	低合金鋼	Low allow steel SCM, SNCM
★	低合金鋼	Hardened SCM, SNCM 硬化處理
	低合金鋼	Hardened SCM, SNCM 硬化處理
	低合金鋼	Hardened SCM, SNCM 硬化處理
★★	高合金鋼	High allow steel SKD, SKT, SKH
	高合金鋼	Hardened SKD, SKT, SKH 硬化處理
★	不鏽鋼	Stainless steel SUS403
★	不鏽鋼	Stainless steel SUS403
★	不鏽鋼	Stainless steel SUS304, SUS316
★★★	鑄鐵	Cast iron
★	球墨鑄鐵	Nodular cast iron
	難削材料	Exotic material 耐熱合金、超合金
★	鋁	Aluminum
★	鋁合金	Aluminum alloy

★★★ 極佳 ★★ 佳 ★ 尚可

型號 Type No	直徑 (D) Diameter	刃長 (L) Flute Length	R角 (D) Corner R	全長 (L) O. A. L.	柄徑 (d) Shank Dia.	牌價 Price
LRGA03053032	3	6	0.5	75	3	720
LRGA03103032	3	6	1.0	75	3	720
LRGA04053042	4	8	0.5	75	4	720
LRGA04103042	4	8	1.0	75	4	720
LRGA06053062	6	12	0.5	75	6	720
LRGA06103062	6	12	1.0	75	6	720
LRGA06153062	6	12	1.5	75	6	720
LRGA06203062	6	12	2.0	75	6	720
LRGA08054082	8	16	0.5	100	8	1585
LRGA08104082	8	16	1.0	100	8	1585
LRGA08154082	8	16	1.5	100	8	1585
LRGA08204082	8	16	2.0	100	8	1585
LRGA08254082	8	16	2.5	100	8	1585
LRGA08304082	8	16	3.0	100	8	1585
LRGA10054102	10	20	0.5	100	10	2000
LRGA10104102	10	20	1.0	100	10	2000
LRGA10154102	10	20	1.5	100	10	2000
LRGA10204102	10	20	2.0	100	10	2000
LRGA10254102	10	20	2.5	100	10	2000
LRGA10304102	10	20	3.0	100	10	2000
LRGA12054122	12	24	0.5	100	12	2470
LRGA12104122	12	24	1.0	100	12	2470
LRGA12154122	12	24	5.0	100	12	2470
LRGA12204122	12	24	2.0	100	12	2470
LRGA12254122	12	24	2.5	100	12	2470
LRGA12304122	12	24	3.0	100	12	2470

Unit : mm

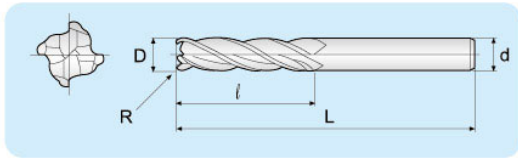

4刃 4 Flutes

●超微粒長柄圓隅角立銑刀  
Micro Grain Long Corner Radius End Mills



型號 Type No	直徑 (D) Diameter	刃長 (L) Flute Length	R角 (D) Corner R	全長 (L) O. A. L.	柄徑 (d) Shank Dia.	牌價 Price
LRGA03053034	3	4	0.5	75	3	720
LRGA03103034	3	4	1.0	75	4	720
LRGA04053044	4	5	0.5	75	4	720
LRGA04103044	4	5	1.0	75	4	720
LRGA06053064	6	7.5	0.5	75	6	720
LRGA06103064	6	7.5	1.0	75	6	720
LRGA06153064	6	7.5	1.5	75	6	720
LRGA06203064	6	7.5	2.0	75	6	720
LRGA08054084	8	10	0.5	100	8	1585
LRGA0804084	8	10	1.0	100	8	1585
LRGA08154084	8	10	1.5	100	8	1585
LRGA08204084	8	10	2.0	100	8	1585
LRGA08254084	8	10	2.5	100	8	1585
LRGA08304084	8	10	3.0	100	8	1585
LRGA10054104	10	12	0.5	100	10	2000
LRGA10104104	10	12	1.0	100	10	2000
LRGA10154104	10	12	1.5	100	10	2000
LRGA10204104	10	12	2.0	100	10	2000
LRGA10254104	10	12	2.5	100	10	2000
LRGA10304104	10	12	3.0	100	10	2000
LRGA12054124	12	14.5	0.5	100	12	2470
LRGA12104124	12	14.5	1.0	100	12	2470
LRGA12154124	12	14.5	1.5	100	12	2470
LRGA1204124	12	14.5	2.0	100	12	2470
LRGA1204124	12	14.5	2.5	100	12	2470
LRGA12304124	12	14.5	3.0	100	12	2470

Unit : mm

產品特色

1. 使用圓隅角立銑刀可提高進給速率，一次加工完成，增加生產效能降低成本。
2. 圓隅角的設計比一般立銑刀更耐磨耗，延長刀具壽命。
3. 應用於模具加工，適用於一般鋼材、難切削材質，如不銹鋼、鋁合金、調質鋼、NAK55、NAK80、高合金鋼等。

FEATURES

The corner radius design strengthens the end mill by reducing chipping, providing longer tool life. Corner more material faster, improve productivity and reduce cost.

適用性	被削鋼材	WORK MATERIAL
★★★	鋼、碳鋼	Steel, Carbon steel S15C
★★★	鋼、碳鋼	Steel, Carbon steel S45C
★★	鋼、碳鋼	Hardened S45C 硬化處理
★	鋼、碳鋼	Steel, Carbon steel S75C
★	鋼、碳鋼	Hardened S75C 硬化處理
★★★	低合金鋼	Low alloy steel SCM, SNCM
★	低合金鋼	Hardened SCM, SNCM 硬化處理
★	低合金鋼	Hardened SCM, SNCM 硬化處理
★	低合金鋼	Hardened SCM, SNCM 硬化處理
★★	高合金鋼	High alloy steel SKD, SKT, SKH
★	高合金鋼	Hardened SKD, SKT, SKH 硬化處理
★	不銹鋼	Stainless steel SUS403
★	不銹鋼	Stainless steel SUS403
★	不銹鋼	Stainless steel SUS304, SUS316
★★★	鑄鐵	Cast iron
★	球墨鑄鐵	Nodular cast iron
★	難削材料	Exotic material 耐熱合金、超合金
★	鋁	Aluminum
★	鋁合金	Aluminum alloy

★★★ 極佳 ★★ 佳 ★ 尚可

※本牌價依市場行情依於折扣優惠，歡迎查詢價格  
The discount will be offered based on current prices. Welcome to check the prices.



## ● 超微粒長刃立銑刀 Micro Grain Long Flute End Mills

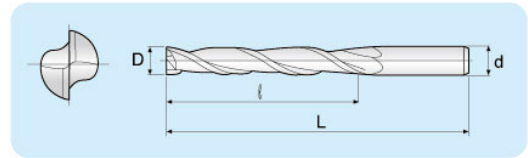

2刃 2 Flutes



標準長刃系列

LONG FLUTE SERIES

**產品特色**

刀刃區近於鏡面，刃口表面光滑，排屑順暢，刀具壽命長，精度也提高。

**FEATURES**

Generally used on wide range of every kind machining. With benefits of fracture resistance and strong edge. Coated TiAlN for maximum heat and wear resistance. Provide maximum hardness and foracture resistance.

適用性	被削鋼材	WORK MATERIAL
★★★	鋼、碳鋼	Steel, Carbon steel S15C
★★★	鋼、碳鋼	Steel, Carbon steel S45C
★★	鋼、碳鋼	Hardened S45C 硬化處理
★	鋼、碳鋼	Steel, Carbon steel S75C
	鋼、碳鋼	Hardened S75C 硬化處理
★★★	低合金鋼	Low allow steel SCM, SNCM
★	低合金鋼	Hardened SCM, SNCM 硬化處理
	低合金鋼	Hardened SCM, SNCM 硬化處理
	低合金鋼	Hardened SCM, SNCM 硬化處理
★★	高合金鋼	High allow steel SKD, SKT, SKH
	高合金鋼	Hardened SKD, SKT, SKH 硬化處理
★	不銹鋼	Stainless steel SUS403
★	不銹鋼	Stainless steel SUS403
★	不銹鋼	Stainless steel SUS304, SUS316
★★★	鑄鐵	Cast iron
★	球墨鑄鐵	Nodular cast iron
	難削材料	Exotic material 耐熱合金、超合金
★	鋁	Aluminum
★	鋁合金	Aluminum alloy

★★★ 極佳 ★★ 佳 ★ 尚可

型號 Type No	直徑 (D) Diameter	刃長 (l) Flute Length	全長 (L) O. A. L.	柄徑 (d) Shank Dia.	牌價 Price
LGFA0101042	1.0	5.0	50	4	1000
LGFA0151042	1.5	7.5	50	4	1000
LGFA0201042	2.0	10	50	4	1000
LGFA0251042	2.5	12.5	50	4	1000
LGFA0301042	3.0	15.0	50	4	1000
LGFA0352042	3.5	17.5	60	4	1000
LGFA0402042	4.0	20.0	60	4	1000
LGFA0453062	4.5	22.5	75	6	1200
LGFA0503062	5.0	25.0	75	6	1200
LGFA0553062	5.5	27.5	75	6	1200
LGFA0603062	6.0	30.0	75	6	1200
LGFA0654082	6.5	32.5	100	8	1400
LGFA0704082	7.0	35	100	8	1400
LGFA0754082	7.5	35	100	8	1400
LGFA0804082	8.0	35	100	8	1400
LGFA0854102	8.5	40	100	10	1860
LGFA0904102	9.0	40	100	10	1860
LGFA1004102	10.0	40	100	10	1860
LGFA1104122	11.0	50	100	12	2350
LGFA1204122	12.0	50	100	12	2350
LGFA1405162	14.0	60	150	16	7650
LGFA1605162	16.0	60	150	16	7650
LGFA2005202	20.0	60	150	20	10350

Unit : mm

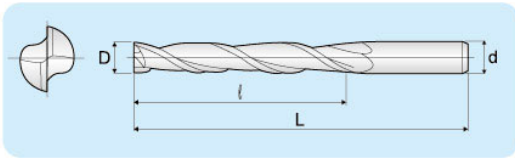

2刃 2 Flutes

● 超微粒長刃立銑刀  
Micro Grain Long Flute End Mills



型號 Type No	直徑 (D) Diameter	刃長 (L) Flute Length	全長 (L) O. A. L.	柄徑 (d) Shank Dia.	牌價 Price
LGF0101042	1.0	5.0	50	4	900
LGF0151042	1.5	7.5	50	4	900
LGF0201042	2.0	10.0	50	4	900
LGF0251042	2.5	12.5	50	4	900
LGF0301042	3.0	15.0	50	4	900
LGF0352042	3.5	17.5	60	4	900
LGF0402042	4.0	20.0	60	4	900
LGF0453062	4.5	22.5	75	6	1080
LGF0503062	5.0	2.05	75	6	1080
LGF0553062	5.5	27.5	75	6	1080
LGF0603062	6.0	30.0	75	6	1080
LGF0654082	6.5	32.5	100	8	1260
LGF0704082	7.0	35	100	8	1260
LGF0754082	7.5	35	100	8	1675
LGF0804082	8.0	35	100	8	1675
LGF0854102	8.5	40	100	10	1675
LGF0904102	9.0	40	100	10	1675
LGF1004102	10.0	40	100	10	1675
LGF1104122	11.0	50	100	12	2115
LGF1204122	12.0	50	100	12	2115
LGF1405162	14.0	60	150	16	6885
LGF1605162	16.0	60	150	16	6885
LGF2005202	20.0	60	150	20	9315

Unit : mm

產品特色

刀刃區近於鏡面，刃口表面光滑，排屑順暢，刀具壽命長，精度也提高。

FEATURES

Generally used on wide range of every kind machining. With benefits of fracture resistance and strong edge.

適用性	被削鋼材	WORK MATERIAL
★★★	鋼、碳鋼	Steel, Carbon steel S15C
★★	鋼、碳鋼	Steel, Carbon steel S45C
★	鋼、碳鋼	Hardened S45C 硬化處理
	鋼、碳鋼	Steel, Carbon steel S75C
	鋼、碳鋼	Hardened S75C 硬化處理
★★	低合金鋼	Low alloy steel SCM, SNCM
	低合金鋼	Hardened SCM, SNCM 硬化處理
	低合金鋼	Hardened SCM, SNCM 硬化處理
	低合金鋼	Hardened SCM, SNCM 硬化處理
★	高合金鋼	High alloy steel SKD, SKT, SKH
	高合金鋼	Hardened SKD, SKT, SKH 硬化處理
	不銹鋼	Stainless steel SUS403
	不銹鋼	Stainless steel SUS403
	不銹鋼	Stainless steel SUS304, SUS316
★★★	鑄鐵	Cast iron
★	球墨鑄鐵	Nodular cast iron
	難削材料	Exotic material 耐熱合金、超合金
★	鋁	Aluminum
★	鋁合金	Aluminum alloy

★★★ 極佳 ★★ 佳 ★ 尚可

※ 本牌價依市場行情依於折扣優惠，歡迎查詢價格  
The discount will be offered based on current prices. Welcome to check the prices.



● **超微粒長刃立銑刀**  
**Micro Grain Long Flute End Mills**

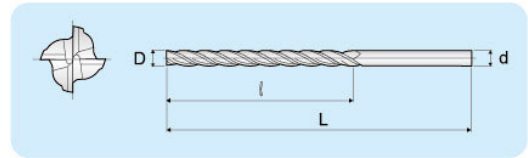

4刃 4 Flutes



標準長刃系列

**產品特色**

刀刃區近於鏡面，刃口表面光滑，排屑順暢，刀具壽命長，精度也提高。

**FEATURES**

Generally used on wide range of every kind machining. With benefits of fracture resistance and strong edge. Coated TiAlN for maximum heat and wear resistance. Provide maximum hardness and fracture resistance.

型號 Type No	直徑 (D) Diameter	刃長 (l) Flute Length	全長 (L) O. A. L.	柄徑 (d) Shank Dia.	牌價 Price
LGFA0101044	1.0	5.0	50	4	1000
LGFA0151044	1.5	7.5	50	4	1000
LGFA0201044	2.0	10.0	50	4	1000
LGFA0251044	2.5	12.5	50	4	1000
LGFA0301044	3.0	15.0	50	4	1000
LGFA0352044	3.5	17.5	60	4	1000
LGFA0402044	4.0	20.0	60	4	1000
LGFA0453064	4.5	22.5	75	6	1200
LGFA0503064	5.0	25.0	75	6	1200
LGFA0553064	5.5	27.5	75	6	1200
LGFA0603064	6.0	30.0	75	6	1200
LGFA0654084	6.5	32.5	100	8	1400
LGFA0704084	7.0	35	100	8	1400
LGFA0754084	7.5	35	100	8	1400
LGFA0804084	8.0	35	100	8	1400
LGFA0854104	8.5	40	100	10	1860
LGFA0904104	9.0	40	100	10	1860
LGFA1004104	10.0	40	100	10	1860
LGFA1104124	11.0	50	100	12	2350
LGFA1204124	12.0	50	100	12	2350
LGFA1405164	14.0	60	150	16	7650
LGFA1605164	16.0	60	150	16	7650
LGFA2005204	20.0	60	150	20	10350

Unit : mm

適用性	被削鋼材	WORK MATERIAL
★★★	鋼、碳鋼	Steel, Carbon steel S15C
★★★	鋼、碳鋼	Steel, Carbon steel S45C
★★	鋼、碳鋼	Hardened S45C 硬化處理
★	鋼、碳鋼	Steel, Carbon steel S75C
	鋼、碳鋼	Hardened S75C 硬化處理
★★★	低合金鋼	Low alloy steel SCM, SNCM
★	低合金鋼	Hardened SCM, SNCM 硬化處理
	低合金鋼	Hardened SCM, SNCM 硬化處理
	低合金鋼	Hardened SCM, SNCM 硬化處理
★★	高合金鋼	High alloy steel SKD, SKT, SKH
	高合金鋼	Hardened SKD, SKT, SKH 硬化處理
★	不銹鋼	Stainless steel SUS403
★	不銹鋼	Stainless steel SUS403
★	不銹鋼	Stainless steel SUS304, SUS316
★★	鑄鐵	Cast iron
★	球墨鑄鐵	Nodular cast iron
	難削材料	Exotic material 耐熱合金、超合金
★	鋁	Aluminum
★	鋁合金	Aluminum alloy

★★★ 極佳 ★★ 佳 ★ 尚可

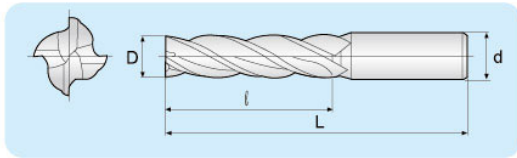

4刃 4 Flutes

● 超微粒長刃立銑刀  
Micro Grain Long Flute End Mills



型號 Type No	直徑 (D) Diameter	刃長 (L) Flute Length	全長 (L) O. A. L.	柄徑 (d) Shank Dia.	牌價 Price
LGF0101044	1.0	5.0	50	4	900
LGF0151044	1.5	7.5	50	4	900
LGF0201044	2.0	10.0	50	4	900
LGF0251044	2.5	12.5	50	4	900
LGF0301044	3.0	15.0	50	4	900
LGF0352044	3.5	17.5	60	4	900
LGF0402044	4.0	20.0	60	4	900
LGF0453064	4.5	22.5	75	6	1080
LGF0503064	5.0	25.0	75	6	1080
LGF0553064	5.5	27.5	75	6	1080
LGF0603064	6.0	30.0	75	6	1080
LGF0654084	6.5	32.5	100	8	1260
LGF0704084	7.0	35	100	8	1260
LGF0754084	7.5	35	100	8	1260
LGF0804084	8.0	35	100	8	1260
LGF0854104	8.5	40	100	10	1675
LGF0904104	9.0	40	100	10	1675
LGF1004104	10.0	40	100	10	1675
LGF1104124	11.0	50	100	12	2115
LGF1204124	12.0	50	100	12	2115
LGF1405164	14.0	60	150	16	6885
LGF1605164	16.0	60	150	16	6885
LGF2005204	20.0	60	150	20	9315

Unit : mm

產品特色

刀刃區近於鏡面，刃口表面光滑，排屑順暢，刀具壽命長，精度也提高。

FEATURES

Generally used on wide range of every kind machining. With benefits of fracture resistance and strong edge.

適用性	被削鋼材	WORK MATERIAL
★★★	鋼、碳鋼	Steel, Carbon steel S15C
★★	鋼、碳鋼	Steel, Carbon steel S45C
★	鋼、碳鋼	Hardened S45C 硬化處理
	鋼、碳鋼	Steel, Carbon steel S75C
	鋼、碳鋼	Hardened S75C 硬化處理
★★	低合金鋼	Low alloy steel SCM, SNCM
	低合金鋼	Hardened SCM, SNCM 硬化處理
	低合金鋼	Hardened SCM, SNCM 硬化處理
	低合金鋼	Hardened SCM, SNCM 硬化處理
★	高合金鋼	High alloy steel SKD, SKT, SKH
	高合金鋼	Hardened SKD, SKT, SKH 硬化處理
	不銹鋼	Stainless steel SUS403
	不銹鋼	Stainless steel SUS403
	不銹鋼	Stainless steel SUS304, SUS316
★★★	鑄鐵	Cast iron
★	球墨鑄鐵	Nodular cast iron
	難削材料	Exotic material 耐熱合金、超合金
★	鋁	Aluminum
★	鋁合金	Aluminum alloy

★★★ 極佳 ★★ 佳 ★ 尚可

※ 本牌價依市場行情依於折扣優惠，歡迎查詢價格  
The discount will be offered based on current prices. Welcome to check the prices.



## ● 超微粒長刃立銑刀 Micro Grain Long Flute End Mills

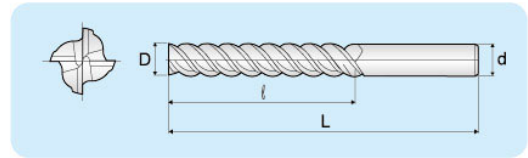

4刃 4 Flutes



標準長刃系列

### 產品特色

螺旋角為45度，切削阻力小，高效能加工，可應用不鏽鋼、高合金鋼、調質鋼、熱處理鋼及難切削材，性能完全發揮。

### FEATURES

Helix angle 45°, less cutting drag, more effective working, best for working on stainless steel, high alloy steel, harden steel, and difficult-machine materials. Coated TiAlN for maximum heat and wear resistance provide maximum hardness and fracture resistance.

適用性	被削鋼材	WORK MATERIAL
★★★	鋼、碳鋼	Steel, Carbon steel S15C
★★★	鋼、碳鋼	Steel, Carbon steel S45C
★★	鋼、碳鋼	Hardened S45C 硬化處理
★★	鋼、碳鋼	Steel, Carbon steel S75C
★	鋼、碳鋼	Hardened S75C 硬化處理
★★★	低合金鋼	Low alloy steel SCM, SNCM
★★	低合金鋼	Hardened SCM, SNCM 硬化處理
★	低合金鋼	Hardened SCM, SNCM 硬化處理
★	低合金鋼	Hardened SCM, SNCM 硬化處理
★★★	高合金鋼	High alloy steel SKD, SKT, SKH
★★	高合金鋼	Hardened SKD, SKT, SKH 硬化處理
★★★	不鏽鋼	Stainless steel SUS403
★★★	不鏽鋼	Stainless steel SUS403
★★★	不鏽鋼	Stainless steel SUS304, SUS316
★★	鑄鐵	Cast iron
★★	球墨鑄鐵	Nodular cast iron
★	難削材料	Exotic material 耐熱合金、超合金
★	鋁	Aluminum
★	鋁合金	Aluminum alloy

★★★ 極佳 ★★ 佳 ★ 尚可

型號 Type No	直徑 (D) Diameter	刃長 (ℓ) Flute Length	全長 (L) O. A. L.	柄徑 (d) Shank Dia.	牌價 Price
LFGA0101044	1.0	5.0	50	4	1000
LFGA0151044	1.5	7.5	50	4	1000
LFGA0201044	2.0	10.0	50	4	1000
LFGA0251044	2.5	12.5	50	4	1000
LFGA0301044	3.0	15.0	50	4	1000
LFGA0352044	3.5	17.5	60	4	1000
LFGA0402044	4.0	20.0	60	4	1000
LFGA0453064	4.5	22.5	75	6	1200
LFGA0503064	5.0	25.0	75	6	1200
LFGA0553064	5.5	27.5	75	6	1200
LFGA0603064	6.0	30.0	75	6	1200
LFGA0654084	6.5	32.5	100	8	1400
LFGA0704084	7.0	35	100	8	1400
LFGA0754084	7.5	35	100	8	1400
LFGA0804084	8.0	35	100	8	1400
LFGA0854104	8.5	40	100	10	1860
LFGA0904104	9.0	40	100	10	1860
LFGA1004104	10.0	40	100	10	1860
LFGA1104124	11.0	50	100	12	2350
LFGA1204124	12.0	50	100	12	2350
LFGA1405164	14.0	60	150	16	7650
LFGA1605164	16.0	60	150	16	7650
LFGA2005204	20.0	60	150	20	10350

Unit : mm

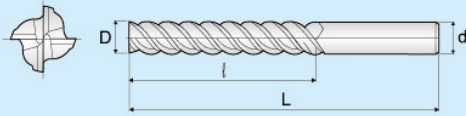

4刃 4 Flutes

● 超微粒長刃立銑刀  
Micro Grain Long Flute End Mills



型號 Type No	直徑 (D) Diameter	刃長 (ℓ) Flute Length	全長 (L) O. A. L.	柄徑 (d) Shank Dia.	牌價 Price
LFG0101044	1.0	5.0	50	4	900
LFG0151044	1.5	7.5	50	4	900
LFG0201044	2.0	10.0	50	4	900
LFG0251044	2.5	12.5	50	4	900
LFG0301044	3.0	15.0	50	4	900
LFG0352044	3.5	17.5	60	4	900
LFG0402044	4.0	20.0	60	4	900
LFG0453064	4.5	22.5	75	6	1080
LFG0503064	5.0	25.0	75	6	1080
LFG0553064	5.5	27.5	75	6	1080
LFG0603064	6.0	30.0	75	6	1080
LFG0654084	6.5	32.5	100	8	1260
LFG0704084	7.0	35	100	8	1260
LFG0754084	7.5	35	100	8	1260
LFG0804084	8.0	35	100	8	1260
LFG0854104	8.5	40	100	10	1675
LFG0904104	9.0	40	100	10	1675
LFG1004104	10.0	40	100	10	1675
LFG1104124	11.0	50	100	12	2115
LFG1204124	12.0	50	100	12	2115
LFG1405164	14.0	60	150	16	6885
LFG1605164	16.0	60	150	16	6885
LFG2005204	20.0	60	150	20	9315

Unit : mm

產品特色

螺旋角為45度，切削阻力小，高效能加工，可應用不鏽鋼、高合金鋼、調質鋼、熱處理鋼及難切削材，性能完全發揮。

FEATURES

Helix angle 45°, less cutting drag, more effective working, best for working on stainless steel, high alloy steel, harden steel, and difficult - machine materials. Coated TiAlN for maximum heat and wear resistance provide maximum hardness and fracture resistance.

適用性	被削鋼材	WORK MATERIAL
★★★	鋼、碳鋼	Steel, Carbon steel S15C
★★	鋼、碳鋼	Steel, Carbon steel S45C
★	鋼、碳鋼	Hardened S45C 硬化處理
	鋼、碳鋼	Steel, Carbon steel S75C
	鋼、碳鋼	Hardened S75C 硬化處理
★★	低合金鋼	Low alloy steel SCM, SNCM
	低合金鋼	Hardened SCM, SNCM 硬化處理
	低合金鋼	Hardened SCM, SNCM 硬化處理
	低合金鋼	Hardened SCM, SNCM 硬化處理
★	高合金鋼	High alloy steel SKD, SKT, SKH
	高合金鋼	Hardened SKD, SKT, SKH 硬化處理
	不鏽鋼	Stainless steel SUS403
	不鏽鋼	Stainless steel SUS403
	不鏽鋼	Stainless steel SUS304, SUS316
★★★	鑄鐵	Cast iron
★	球墨鑄鐵	Nodular cast iron
	難削材料	Exotic material 耐熱合金、超合金
★	鋁	Aluminum
★	鋁合金	Aluminum alloy

★★★ 極佳 ★★ 佳 ★ 尚可

※ 本牌價依市場行情依於折扣優惠，歡迎查詢價格  
The discount will be offered based on current prices. Welcome to check the prices.



● 超微粒長刃立銑刀  
Micro Grain Long Flute End Mills

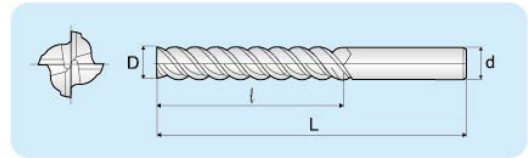

4刃 4 Flutes



長刃高硬度系列  
LONG FLUTE HIGH HARDNESS SERIES

**產品特色**

螺旋角為45度，切削阻力小，高效能加工，可應用不鏽鋼、高合金鋼、調質鋼、熱處理鋼及難切削材，性能完全發揮。

**FEATURES**

Helix angle 45°, less cutting drag, more effective working, best for working on stainless steel, high alloy steel, harden steel, and difficult - machine materials. Coated TiAlN for maximum heat and wear resistance provide maximum hardness and fracture resistance.

適用性	被削鋼材	WORK MATERIAL
★★★	鋼、碳鋼	Steel, Carbon steel S15C
★★★	鋼、碳鋼	Steel, Carbon steel S45C
★★	鋼、碳鋼	Hardened S45C 硬化處理
★★	鋼、碳鋼	Steel, Carbon steel S75C
★	鋼、碳鋼	Hardened S75C 硬化處理
★★★	低合金鋼	Low allow steel SCM, SNCM
★★	低合金鋼	Hardened SCM, SNCM 硬化處理
★	低合金鋼	Hardened SCM, SNCM 硬化處理
★	低合金鋼	Hardened SCM, SNCM 硬化處理
★★★	高合金鋼	High allow steel SKD, SKT, SKH
★★	高合金鋼	Hardened SKD, SKT, SKH 硬化處理
★★★	不鏽鋼	Stainless steel SUS403
★★★	不鏽鋼	Stainless steel SUS403
★★★	不鏽鋼	Stainless steel SUS304, SUS316
★★	鑄鐵	Cast iron
★★	球墨鑄鐵	Nodular cast iron
★	難削材料	Exotic material 耐熱合金、超合金
★	鋁	Aluminum
★	鋁合金	Aluminum alloy

★★★ 極佳 ★★ 佳 ★ 尚可

型號 Type No	直徑 (D) Diameter	刃長 (ℓ) Flute Length	全長 (L) O. A. L.	柄徑 (d) Shank Dia.	牌價 Price
LXGA0101044	1.0	5.0	50	4	900
LXGA0151044	1.5	7.5	50	4	900
LXGA0201044	2.0	10.0	50	4	900
LXGA0251044	2.5	12.5	50	4	900
LXGA0301044	3.0	15.0	50	4	900
LXGA0352044	3.5	17.5	60	4	900
LXGA0402044	4.0	20.0	60	4	900
LXGA0453064	4.5	22.5	75	6	1080
LXGA0503064	5.0	25.0	75	6	1080
LXGA0553064	5.5	27.5	75	6	1080
LXGA0603064	6.0	30.0	75	6	1080
LXGA0654084	6.5	32.5	100	8	1260
LXGA0704084	7.0	35	100	8	1260
LXGA0754084	7.5	35	100	8	1260
LXGA0804084	8.0	35	100	8	1260
LXGA0854104	8.5	40	100	10	1675
LXGA0904104	9.0	40	100	10	1675
LXGA1004104	10.0	40	100	10	1675
LXGA1104124	11.0	50	100	12	2115
LXGA1204124	12.0	50	100	12	2115
LXGA1405164	14.0	60	150	16	6885
LXGA1605164	16.0	60	150	16	6885
LXGA2005204	20.0	60	150	20	9315

Unit : mm

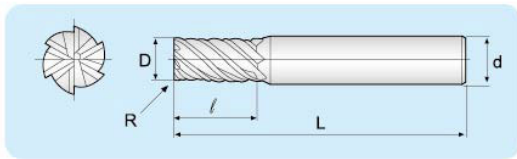

6刃 6 Flutes

● 超微粒長刃高硬度立銑刀  
Micro Grain Long High Hardness End Mills



型號 Type No	直徑 (D) Diameter	刃長 (ℓ) Flute Length	全長 (L) O. A. L.	柄徑 (d) Shank Dia.	牌價 Price
LVGA0101046	1.0	5.0	50	4	1350
LVGA0151046	1.5	7.5	50	4	1350
LVGA0201046	2.0	10.0	50	4	1350
LVGA0251046	2.5	12.5	50	4	1350
LVGA0301046	3.0	15.0	50	4	1350
LVGA0352046	3.5	17.5	60	4	1350
LVGA0402046	4.0	20.0	60	4	1350
LVGA0453066	4.5	22.5	75	6	1620
LVGA0503066	5.0	25.0	75	6	1620
LVGA0553066	5.5	27.5	75	6	1620
LVGA0603066	6.0	30.0	75	6	1620
LVGA0654086	6.5	32.5	100	8	1890
LVGA0704086	7.0	35	100	8	1890
LVGA0754086	7.5	35	100	8	1890
LVGA0804086	8.0	35	100	8	1890
LVGA0854106	8.5	40	100	10	2511
LVGA0904106	9.0	40	100	10	2511
LVGA1004106	10.0	40	100	10	2511
LVGA1104126	11.0	50	100	12	3173
LVGA1204126	12.0	50	100	12	3173
LVGA1405166	14.0	60	150	16	10328
LVGA1605166	16.0	60	150	16	10328
LVGA2005206	20.0	60	150	20	10328

Unit : mm

產品特色

1. 高硬度加工用，針對熱處理鋼材 HRC60 以上，性能完全發揮。
2. 刀刃區近於鏡面，刃口表面光滑，排屑順暢，刀具壽命長，精度也提高。
3. 使用高速切削，可得到非常光滑的表面。

FEATURES

Exceptionally strong which improve surface finishes and high feed rates. Coated TiAlN for maximum heat and wear resistance provide maximum hardness and fracture resistance.

適用性	被削鋼材	WORK MATERIAL
★★★	鋼、碳鋼	Steel, Carbon steel S15C
★★★	鋼、碳鋼	Steel, Carbon steel S45C
★★	鋼、碳鋼	Hardened S45C 硬化處理
★★	鋼、碳鋼	Steel, Carbon steel S75C
★	鋼、碳鋼	Hardened S75C 硬化處理
★★★	低合金鋼	Low allow steel SCM, SNCM
★★	低合金鋼	Hardened SCM, SNCM 硬化處理
★	低合金鋼	Hardened SCM, SNCM 硬化處理
★	低合金鋼	Hardened SCM, SNCM 硬化處理
★★★	高合金鋼	High allow steel SKD, SKT, SKH
★	高合金鋼	Hardened SKD, SKT, SKH 硬化處理
★★★	不銹鋼	Stainless steel SUS403
★★★	不銹鋼	Stainless steel SUS403
★★★	不銹鋼	Stainless steel SUS304, SUS316
★★	鑄鐵	Cast iron
★★	球墨鑄鐵	Nodular cast iron
★	難削材料	Exotic material 耐熱合金、超合金
★	鋁	Aluminum
★	鋁合金	Aluminum alloy

★★★ 極佳 ★★ 佳 ★ 尚可

※ 本牌價依市場行情依於折扣優惠，歡迎查詢價格  
The discount will be offered based on current prices. Welcome to check the prices.



## ● 超微粒深溝圓頭立銑刀 Micro Grain Taper End Mills

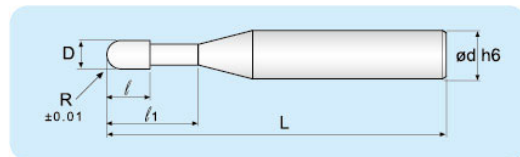

4刃 4 Flutes



### 產品特色

刀刃區近於鏡面，刃口表面光滑，排屑順暢，刀具壽命長，精度也提高。

### FEATURES

Generally used on wide range of every kind machining. With benefits of fracture resistance and strong edge. Coated TiAlN for maximum heat and wear resistance. Provide maximum hardness and fracture resistance.

型號 Type No	R角 Corner R	刃長( $l$ ) Flute Length	有效長( $l_1$ ) Lange Min Dia	全長(L) O. A. L.	柄徑(d) Shank Dia.	牌價 Price
LBHA020005454	0.2	0.4	0.5	45	4	715
LBHA020010454	0.2	0.4	1	45	4	715
LBHA020015454	0.2	0.4	1.5	45	4	715
LBHA020020454	0.2	0.4	2	45	4	715
LBHA020030454	0.2	0.4	3	45	4	715
LBHA020040454	0.2	0.4	4	45	4	715
LBHA020050454	0.2	0.4	5	45	4	810
LBHA025010454	0.25	0.5	1	45	4	655
LBHA025020454	0.25	0.5	2	45	4	655
LBHA025030454	0.25	0.5	3	45	4	655
LBHA025040454	0.25	0.5	4	45	4	655
LBHA025050454	0.25	0.5	5	45	4	655
LBHA025060454	0.25	0.5	6	45	4	765
LBHA025080454	0.25	0.5	8	45	4	765
LBHA030010454	0.3	0.6	1	45	4	655
LBHA030020454	0.3	0.6	2	45	4	655
LBHA030030454	0.3	0.6	3	45	4	655
LBHA030040454	0.3	0.6	4	45	4	655
LBHA030050454	0.3	0.6	5	45	4	655
LBHA030060454	0.3	0.6	6	45	4	655
LBHA060080454	0.3	0.6	8	45	4	765
LBHA030100454	0.3	0.6	10	45	4	765
LBHA040020454	0.4	0.8	2	45	4	605
LBHA040040454	0.4	0.8	4	45	4	605
LBHA040060454	0.4	0.8	6	45	4	605
LBHA040080454	0.4	0.8	8	45	4	605
LBHA040100454	0.4	0.8	10	45	4	765
LBHA050030454	0.5	1.0	3	45	4	555
LBHA050040454	0.5	1.0	4	45	4	555

Unit : mm

深溝圓頭系列

TAPER END MILLS SERIES

適用性	被削鋼材	WORK MATERIAL
★★★	鋼、碳鋼	Steel, Carbon steel S15C
★★★	鋼、碳鋼	Steel, Carbon steel S45C
★★	鋼、碳鋼	Hardened S45C 硬化處理
★	鋼、碳鋼	Steel, Carbon steel S75C
	鋼、碳鋼	Hardened S75C 硬化處理
★★★	低合金鋼	Low allow steel SCM, SNCM
★	低合金鋼	Hardened SCM, SNCM 硬化處理
	低合金鋼	Hardened SCM, SNCM 硬化處理
	低合金鋼	Hardened SCM, SNCM 硬化處理
★★	高合金鋼	High allow steel SKD, SKT, SKH
	高合金鋼	Hardened SKD, SKT, SKH 硬化處理
★	不銹鋼	Stainless steel SUS403
★	不銹鋼	Stainless steel SUS403
★	不銹鋼	Stainless steel SUS304, SUS316
★★★	鑄鐵	Cast iron
★	球墨鑄鐵	Nodular cast iron
	難削材料	Exotic material 耐熱合金、超合金
★	鋁	Aluminum
★	鋁合金	Aluminum alloy

★★★ 極佳 ★★ 佳 ★ 尚可

型號 Type No	R角 Corner R	刃長(ℓ) Flute Length	有效長(ℓ1) Lange Min Dia	全長(L) O. A. L.	柄徑(d) Shank Dia.	牌價 Price
LBHA050050454	0.5	1	5	45	4	555
LBHA050060454	0.5	1	6	45	4	555
LBHA050070454	0.5	1	7	45	4	555
LBHA050080454	0.5	1	8	45	4	555
LBHA050100454	0.5	1	10	45	4	555
LBHA050120454	0.5	1	12	45	4	585
LBHA050140504	0.5	1	14	50	4	585
LBHA050160504	0.5	1	16	50	4	630
LBHA150200554	0.5	1	20	55	4	665
LBHA060040454	0.6	1.2	4	45	4	555
LBHA060060454	0.6	1.2	6	45	4	555
LBHA060080454	0.6	1.2	8	45	4	555
LBHA060100454	0.6	1.2	10	45	4	555
LBHA060120454	0.6	1.2	12	45	4	585
LBHA070080454	0.7	1.4	8	45	4	555
LBHA070120454	0.7	1.4	12	45	4	585
LBHA070160504	0.7	1.4	16	50	4	630
LBHA075040454	0.75	1.5	4	45	4	555
LBHA075060454	0.75	1.5	6	45	4	555
LBHA075080454	0.75	1.5	8	45	4	555
LBHA075100454	0.75	1.5	10	45	4	555
LBHA075120454	0.75	1.5	12	45	4	585
LBHA075140504	0.75	1.5	14	50	4	585
LBHA075160504	0.75	1.5	16	50	4	630
LBHA075200554	0.75	1.5	20	55	4	630
LBHA080080454	0.8	1.6	8	45	4	555
LBHA080120454	0.8	1.6	12	45	4	585
LBHA080160504	0.8	1.6	16	50	4	630
LBHA080200554	0.8	1.6	20	55	4	630
LBHA090080454	0.9	1.8	8	45	4	555
LBHA090120454	0.9	1.8	12	45	4	585
LBHA090160504	0.9	1.8	16	50	4	630
LBHA090200554	0.9	1.8	20	55	4	630
LBHA100040454	1	2	4	45	4	525
LBHA100060454	1	2	6	45	4	525
LBHA100080454	1	2	8	45	4	525
LBHA100100454	1	2	10	45	4	525
LBHA100120504	1	2	12	50	4	525
LBHA100140504	1	2	14	50	4	555

Unit : mm

型號 Type No	R角 Corner R	刃長(ℓ) Flute Length	有效長(ℓ1) Lange Min Dia	全長(L) O. A. L.	柄徑(d) Shank Dia.	牌價 Price
LBHA100160504	1	2	16	50	4	555
LBHA100180554	1	2	18	55	4	585
LBHA100200554	1	2	20	55	4	585
LBHA100220604	1	2	22	60	4	585
LBHA100260704	1	2	26	70	4	680
LBHA100300704	1	2	30	70	4	680
LBHA125080506	1.25	2.5	8	50	6	790
LBHA125100506	1.25	2.5	10	50	6	790
LBHA125160556	1.25	2.5	16	55	6	790
LBHA125200606	1.25	2.5	20	60	6	850
LBHA150080506	1.5	3	8	50	6	790
LBHA150100506	1.5	3	10	50	6	790
LBHA150120506	1.5	3	12	50	6	790
LBHA150140556	1.5	3	14	55	6	790
LBHA150160556	1.5	3	16	55	6	790
LBHA150180606	1.5	3	18	60	6	850
LBHA150200606	1.5	3	20	60	6	850
LBHA150260706	1.5	3	26	70	6	900
LBHA150300706	1.5	3	30	70	6	900
LBHA150360806	1.5	3	36	80	6	995
LBHA200100606	2	4	10	60	6	790
LBHA200120606	2	4	12	60	6	790
LBHA200160606	2	4	16	60	6	790
LBHA200200656	2	4	20	65	6	850
LBHA200260706	2	4	26	70	6	900
LBHA200300706	2	4	30	70	6	900
LBHA200360806	2	4	36	80	6	995
LBHA200400906	2	4	40	90	6	1195
LBHA200460906	2	4	46	90	6	1195
LBHA200500106	2	4	50	100	6	1275
LBHA250160606	2.5	5	16	60	6	790
LBHA250200606	2.5	5	20	60	6	850
LBHA250260706	2.5	5	26	70	6	850
LBHA250300806	2.5	5	30	80	6	900
LBHA250360806	2.5	5	36	80	6	995
LBHA300200806	3	6	20	80	6	995
LBHA300300906	3	6	30	90	6	1195
LBHA300400106	3	6	40	100	6	1275
LBHA300500116	3	6	50	110	6	1275



● 超微粒斜度立銑刀  
Micro Grain Taper End Mills

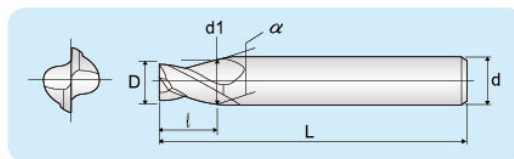

2刃 2 Flutes



產品特色

刀刃區近於鏡面，刃口表面光滑，排屑順暢，刀具壽命長，精度也提高。

FEATURES

Generally used on wide range of every kind machining. With benefits of fracture resistance and strong edge.

型號 Type No	先端徑 (D) Small Min Dia	刃長 (ℓ) Flute Length	斜角 (α) Taper Angle	粗端徑 (d1) Large Min Dia	全長 (L) O. A. L.	柄徑 (d) Shank Dia.	牌價 Price
TGA005051042	0.5	2	30'	0.6	50	4	1380
TGA005101042	0.5	2	1°	0.5	50	4	1380
TGA005151042	0.5	2	1° 30'	0.5	50	4	1380
TGA005301042	0.5	2	3°	0.6	50	4	1380
TGA005251042	0.5	2	2° 30'	0.6	50	4	1380
TGA005301042	0.5	2	3°	0.5	50	4	1380
TGA005501042	0.5	2	5°	0.6	50	4	1380
TGA005701042	0.5	2	7°	0.5	50	4	1650
TGA0051001042	0.5	2	10°	0.6	50	4	1650
TGA010051042	1.0	4	30'	1.7	50	4	980
TGA010101042	1.0	4	1°	1.14	50	4	980
TGA010151042	1.0	4	1° 30'	1.21	50	4	980
TGA010201042	1.0	4	2°	1.28	50	4	980
TGA010251042	1.0	4	2° 30'	1.35	50	4	980
TGA010301042	1.0	4	3°	1.42	50	4	980
TGA010501042	1.0	4	5°	1.70	50	4	1280
TGA010701042	1.0	4	7°	1.98	50	4	1280
TGA015051042	1.5	5	30'	1.59	50	4	980
TGA015101042	1.5	5	1°	1.67	50	4	980
TGA015151042	1.5	5	1° 30'	1.76	50	4	980
TGA015201042	11.5	5	2°	1.85	50	4	980
TGA015251042	1.5	5	2° 30'	1.93	50	4	980
TGA015301042	1.5	5	3°	2.02	50	4	980
TGA015501042	1.5	5	5°	2.37	50	4	1280
TGA015701042	1.5	5	7°	2.72	50	4	1280
TGA0151001042	1.5	5	10°	3.26	50	4	1280
TGA020051042	2.0	6	30'	2.10	50	4	980
TGA020101042	2.0	6	1°	2.21	50	4	980
TGA020151042	2.0	6	1° 30'	2.31	50	4	980
TGA020201042	2.0	6	2°	2.41	50	4	980

Unit : mm

斜度系列  
TAPER SERIES

適用性	被削鋼材	WORK MATERIAL
★★★	鋼、碳鋼	Steel, Carbon steel S15C
★★★	鋼、碳鋼	Steel, Carbon steel S45C
★★	鋼、碳鋼	Hardened S45C 硬化處理
★	鋼、碳鋼	Steel, Carbon steel S75C
	鋼、碳鋼	Hardened S75C 硬化處理
★★★	低合金鋼	Low allow steel SCM, SNCM
★	低合金鋼	Hardened SCM, SNCM 硬化處理
	低合金鋼	Hardened SCM, SNCM 硬化處理
	低合金鋼	Hardened SCM, SNCM 硬化處理
★★	高合金鋼	High allow steel SKD, SKT, SKH
	高合金鋼	Hardened SKD, SKT, SKH 硬化處理
★	不銹鋼	Stainless steel SUS403
★	不銹鋼	Stainless steel SUS403
★	不銹鋼	Stainless steel SUS304, SUS316
★★★	鑄鐵	Cast iron
★	球墨鑄鐵	Nodular cast iron
	難削材料	Exotic material 耐熱合金、超合金
★	鋁	Aluminum
★	鋁合金	Aluminum alloy

★★★ 極佳 ★★ 佳 ★ 尚可



型號 Type No	先端徑(D) Small Min Dia	刃長(ℓ) Flute Length	斜角 Taper Angle	粗端徑(L) Lange Min Dia	全長(L) O. A. L.	柄徑(d) Shank Dia.	牌價 Price	型號 Type No	先端徑(D) Small Min Dia	刃長(ℓ) Flute Length	斜角 Taper Angle	粗端徑(L) Lange Min Dia	全長(L) O. A. L.	柄徑(d) Shank Dia.	牌價 Price
TGA020251042	2.0	6	2° 30'	2.52	50	4	980	TGA040702062	4.0	15	7°	7.68	60	6	1780
TGA020301042	2.0	6	3°	2.62	50	4	980	TGA050052062	5.0	20	30'	5.34	60	6	1380
TGA020501042	2.0	6	5°	3.05	50	4	1280	TGA050102062	5.0	20	1°	5.70	60	6	1380
TGA020701042	2.0	6	7°	3.47	50	4	1280	TGA050152062	5.0	20	1° 30'	6.04	60	6	1380
TGA0201001042	2.0	6	10°	4.12	50	4	1280	TGA050202062	5.0	20	2°	6.39	60	6	1380
TGA025051042	2.5	8	30'	2.64	50	4	980	TGA050252062	5.0	20	2° 30'	6.74	60	6	1380
TGA025101042	2.5	8	1°	2.71	50	4	980	TGA050302062	5.0	20	3°	7.10	60	6	1380
TGA025151042	2.5	8	1° 30'	2.91	50	4	980	TGA050503062	5.0	20	5°	8.50	70	6	1880
TGA025201042	2.5	8	2°	3.05	50	4	980	TGA050703062	5.0	20	7°	9.91	70	6	2080
TGA025251042	2.5	8	2° 30'	3.20	50	4	1280	TGA060051062	6.0	20	30'	6.35	60	6	1380
TGA025301042	2.5	8	3°	3.33	50	4	1280	TGA060101062	6.0	20	1°	6.70	60	6	1380
TGA025501042	2.5	8	5°	3.90	50	4	1280	TGA060152062	6.0	20	1° 30'	7.05	60	6	1380
TGA025701062	2.5	8	7°	4.46	50	6	980	TGA060202062	6.0	20	2°	7.40	60	6	1380
TGA0251001062	2.5	8	10°	5.32	50	6	980	TGA060252062	6.0	20	2° 30'	7.75	60	6	1780
TGA030051062	3.0	10	30'	3.17	50	6	980	TGA060302062	6.0	20	3°	8.10	60	8	1780
TGA030101062	3.0	10	1°	3.35	50	6	980	TGA060505082	6.0	20	5°	9.50	80	8	2080
TGA030151062	3.0	10	1° 30'	3.52	50	6	950	TGA080053082	8.0	25	30'	8.44	70	8	2080
TGA030201062	3.0	10	2°	3.69	50	6	950	TGA080103082	8.0	25	1°	8.87	70	8	2080
TGA030251062	3.0	10	2° 30'	3.87	50	6	980	TGA080153082	8.0	25	1° 30'	9.31	70	8	2080
TGA030301062	3.0	10	3°	4.05	50	6	980	TGA080203082	8.0	25	2°	9.74	70	8	2080
TGA030501062	3.0	10	5°	4.75	50	6	1280	TGA080253102	8.0	25	2° 30'	10.18	70	10	2880
TGA030701062	3.0	10	7°	5.45	50	6	1580	TGA08302102	8.0	25	3°	10.62	70	10	2880
TGA0301001062	3.0	10	10°	6.53	50	6	1780	TGA08503122	8.0	25	5°	12.37	90	12	3280
TGA040051062	4.0	15	30'	4.26	50	6	980	TGA10053102	10.0	35	30'	10.61	90	10	2880
TGA040101062	4.0	15	1°	4.52	50	6	980	TGA10103102	10.0	35	1°	11.22	90	10	2880
TGA040151062	4.0	15	1° 30'	4.79	50	6	980	TGA10153102	10.0	35	1° 30'	11.83	90	10	2880
TGA040201062	4.0	15	2°	5.04	50	6	980	TGA10203122	10.0	35	2°	12.44	90	12	3580
TGA040251062	4.0	15	2° 30'	5.31	50	6	980	TGA10253122	10.0	35	2° 30'	13.06	90	12	3880
TGA040301062	4.0	15	3°	5.57	50	6	980	TGA10503162	10.0	35	5°	16.12	115	16	5280
TGA040501062	4.0	15	5°	6.62	50	6	1580								

Unit : mm

※本牌價依市場行情依於折扣優惠，歡迎查詢價格  
The discount will be offered based on current prices. Welcome to check the prices.



● 超微粒鋁用立銑刀  
Micro Grain End Mills

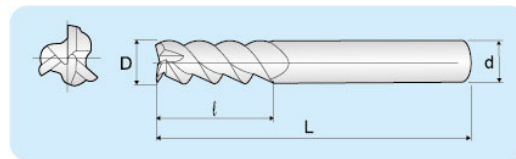

3刃 3 Flutes



型號 Type No	直徑 (D) Diameter	刃長 (l) Flute Length	全長 (L) O. A. L.	柄徑 (d) Shank Dia.	牌價 Price
AEC0051043	0.5	1.25	50	4	1100
AEC0061043	0.6	1.5	50	4	1100
AEC0081043	0.8	2.0	50	6	1100
AEC0101063	1.0	2.5	50	6	530
AEC0121063	1.2	9.5	50	6	530
AEC0151063	1.5	4.0	50	6	530
AEC0181063	1.8	4.5	50	6	530
AEC0201063	2.0	5.0	50	6	530
AEC0301063	3.0	7.5	50	6	530
AEC0401063	4.0	10.0	50	6	530
AEC0501063	5.0	12.5	50	6	530
AEC0601063	6.0	15.0	50	6	530
AEC0802083	8.0	20.0	60	8	1050
AEC1003103	10.0	25.0	75	10	1650
AEC1203123	12.0	30.0	75	12	2200

Unit : mm

產品特色

特殊切削角度與特殊刃口設計，針對輕合金加工有良好表現，高效能排屑效果，特別在鋁合金加工可高速切削，達到光滑的表面。

FEATURES

Generally used on wide range of every kind machining. With benefits of fracture resistance and strong edge. Coated TiAlN for maximum heat and wear resistance. Provide maximum hardness and fracture resistance.

適用性	被削鋼材	WORK MATERIAL
★★★	鋼、碳鋼	Steel, Carbon steel S15C
★★★	鋼、碳鋼	Steel, Carbon steel S45C
★★★	鋼、碳鋼	Hardened S45C 硬化處理
★★★	鋼、碳鋼	Steel, Carbon steel S75C
★★★	鋼、碳鋼	Hardened S75C 硬化處理
★★★	低合金鋼	Low alloy steel SCM, SNCM
★★★	低合金鋼	Hardened SCM, SNCM 硬化處理
★★★	低合金鋼	Hardened SCM, SNCM 硬化處理
★★★	低合金鋼	Hardened SCM, SNCM 硬化處理
★★★	高合金鋼	High alloy steel SKD, SKT, SKH
★★★	高合金鋼	Hardened SKD, SKT, SKH 硬化處理
★★★	不銹鋼	Stainless steel SUS403
★★★	不銹鋼	Stainless steel SUS403
★★★	不銹鋼	Stainless steel SUS304, SUS316
★★★	鑄鐵	Cast iron
★★★	球墨鑄鐵	Nodular cast iron
★★★	難削材料	Exotic material 耐熱合金、超合金
★★★	鋁	Aluminum
★★★	鋁合金	Aluminum alloy

★★★ 極佳 ★★ 佳 ★ 尚可

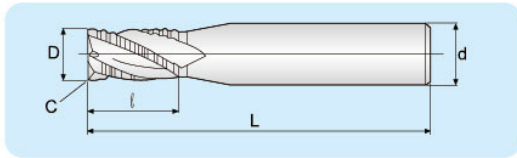

4刃 4 Flutes

● 超微粒粗齒立銑刀  
Micro Grain Roughing End Mill



型號 Type No	直徑(D) Diameter	刃長(L) Flute Length	刀尖倒角 (C)	全長(L) O. A. L.	柄徑(d) Shank Dia.	牌價 Price
GCAE0601064	6	15	0.5	50	6	630
GCAE0802084	8	20	0.5	60	8	1260
GCAE1003104	10	25	0.5	75	10	1950
GCAE1203124	12	30	0.5	75	12	2625
GCAE1404164	14	35	0.5	100	16	6675
GCAE1604164	16	40	0.6	100	16	6675
GCAE1804204	18	40	0.6	100	20	9300
GCAE2004204	20	40	0.6	100	20	9300
GCAE2204254	22	45	0.6	100	25	20000
GCAE2504254	25	50	0.6	100	25	20000

Unit : mm

產品特色

刀刃區近於鏡面，刃口表面光滑，排屑順暢，刀具壽命長，精度也提高。

FEATURES

Generally used on wide range of every kind machining. With benefits of fracture resistance and strong edge. Coated TiAlN for maximum heat and wear resistance. Provide maximum hardness and fracture resistance.

適用性	被削鋼材	WORK MATERIAL
★★★★	鋼、碳鋼	Steel, Carbon steel S15C
★★★★	鋼、碳鋼	Steel, Carbon steel S45C
★★	鋼、碳鋼	Hardened S45C 硬化處理
★★	鋼、碳鋼	Hardened S75C 硬化處理
★	鋼、碳鋼	Hardened S75C 硬化處理
★★★★	低合金鋼	Low allow steel SCM, SNCM
★★	低合金鋼	Hardened SCM, SNCM 硬化處理
★	低合金鋼	Hardened SCM, SNCM 硬化處理
★	低合金鋼	Hardened SCM, SNCM 硬化處理
★★★★	高合金鋼	High allow steel SKD, SKT, SKH
★	高合金鋼	Hardened SKD, SKT, SKH 硬化處理
★★★★	不銹鋼	Stainless steel SUS403
★★★★	不銹鋼	Stainless steel SUS403
★★★★	不銹鋼	Stainless steel SUS304, SUS316
★★	鑄鐵	Cast iron
★★	球墨鑄鐵	Nodular cast iron
★	難削材料	Exotic material 耐熱合金、超合金
★	鋁	Aluminum
★	鋁合金	Aluminum alloy

★★★★ 極佳 ★★ 佳 ★ 尚可



## ● 超微粒定位鑽 Micro Grain Orientate Drill

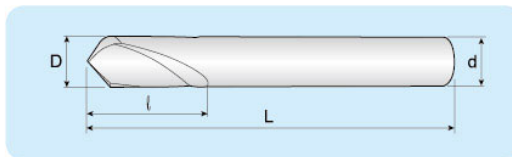

### 產品特色

刀刃區近於鏡面，刃口表面光滑，排屑順暢，刀具壽命長，精度也提高。

### FEATURES

Generally used on wide range of every kind machining. With benefits of fracture resistance and strong edge. Coated TialN for maximum heat and wear resistance. Provide maximum hardness and fracture resistance.



型號 Type No	直徑 (D) Diameter	刃長 (ℓ) Flute Length	全長 (L) O. A. L.	柄徑 (d) Shank Dia.	牌價 Price
WPA3	3	4.5	75	6	510
WPA4	4	6	75	6	510
WPA6	6	9	75	6	510
WPA8	8	12	100	8	1010
WPA10	10	15	100	10	1560
WPA12	12	18	100	12	2100
WPA16	16	24	150	16	5340
WPA20	20	30	150	20	7440

Unit : mm

## ● 長柄超微粒定位鑽 Micro Grain Long Shank Orientate Drill

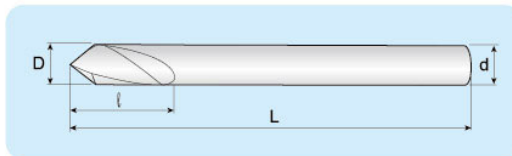

型號 Type No	直徑 (D) Diameter	刃長 (ℓ) Flute Length	全長 (L) O. A. L.	柄徑 (d) Shank Dia.	牌價 Price
LWPA3	3	4.5	100	6	510
LWPA4	4	6	100	6	510
LWPA6	6	9	100	6	510
LWPA8	8	12	150	8	1010
LWPA10	10	15	150	10	1560
LWPA12	12	18	150	12	2100
LWPA16	16	24	150	16	5340
LWPA20	20	30	150	20	7440

Unit : mm

適用性	被削鋼材	WORK MATERIAL
★★★	鋼、碳鋼	Steel, Carbon steel S15C
★★★	鋼、碳鋼	Steel, Carbon steel S45C
★★	鋼、碳鋼	Hardened Steel, Carbon steel S45C 硬化處理
★★	鋼、碳鋼	Steel, Carbon steel S75C
★	鋼、碳鋼	Hardened S75C 硬化處理
★★★	低合金鋼	Low alloy steel SCM, SNCM
★★	低合金鋼	Hardened SCM, SNCM 硬化處理
★	低合金鋼	Hardened SCM, SNCM 硬化處理
★	低合金鋼	Hardened SCM, SNCM 硬化處理
★★★	高合金鋼	High alloy steel SKD, SKT, SKH
★	高合金鋼	Hardened SKD, SKT, SKH 硬化處理
★★★	不銹鋼	Stainless steel SUS403
★★★	不銹鋼	Stainless steel SUS403
★★★	不銹鋼	Stainless steel SUS304, SUS316
★★	鑄鐵	Cast iron
★★	球墨鑄鐵	Nodular cast iron
★	難削材料	Exotic material 耐熱合金、超合金
★	鋁	Aluminum
★	鋁合金	Aluminum alloy

★★★ 極佳 ★★ 佳 ★ 尚可

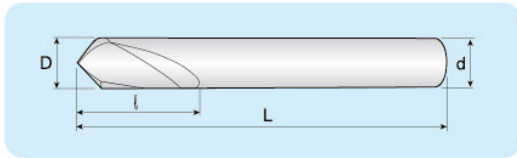

### ● 超微粒定位鑽

## Micro Grain Orientate Drill



型號 Type No	直徑 (D) Diameter	刃長 (l) Flute Length	全長 (L) O. A. L.	柄徑 (d) Shank Dia.	牌價 Price
WP3	3	4.5	50	6	460
WP4	4	6	50	6	460
WP6	6	9	50	6	460
WP8	8	12	60	8	920
WP10	10	15	75	10	1410
WP12	12	18	75	12	1890
WP16	16	24	100	16	5340
WP20	20	30	100	20	7440

Unit : mm

#### 產品特色

刀刃區近於鏡面，刃口表面光滑，排屑順暢，刀具壽命長，精度也提高。

#### FEATURES

Generally used on wide range of every kind machining. With benefits of fracture resistance and strong edge. Coated TiAlN for maximum heat and wear resistance. Provide maximum hardness and fracture resistance.

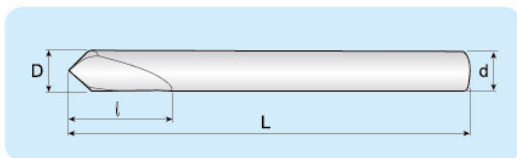

### ● 長柄超微粒定位鑽

## Micro Grain Long Shank Orientate Drill



型號 Type No	直徑 (D) Diameter	刃長 (l) Flute Length	全長 (L) O. A. L.	柄徑 (d) Shank Dia.	牌價 Price
LWP3	3	4.5	100	6	460
LWP4	4	6	100	6	460
LWP6	6	9	100	6	460
LWP8	8	12	150	8	920
LWP10	10	15	150	10	1410
LWP12	12	18	150	12	1890
LWP16	16	24	150	16	5340
LWP20	20	30	150	20	7440

Unit : mm

適用性	被削鋼材	WORK MATERIAL
★★★	鋼、碳鋼	Steel, Carbon steel S15C
★★	鋼、碳鋼	Steel, Carbon steel S45C
★	鋼、碳鋼	Steel, Carbon steel S45C 硬化處理
	鋼、碳鋼	Steel, Carbon steel S75C
	鋼、碳鋼	Hardened S75C 硬化處理
★★	低合金鋼	Low alloy steel SCM, SNCM
	低合金鋼	Hardened SCM, SNCM 硬化處理
	低合金鋼	Hardened SCM, SNCM 硬化處理
	低合金鋼	Hardened SCM, SNCM 硬化處理
★	高合金鋼	High alloy steel SKD, SKT, SKH
	高合金鋼	Hardened SKD, SKT, SKH 硬化處理
	不銹鋼	Stainless steel SUS403
	不銹鋼	Stainless steel SUS403
	不銹鋼	Stainless steel SUS304, SUS316
★★★	鑄鐵	Cast iron
	球墨鑄鐵	Nodular cast iron
	難削材料	Exotic material 耐熱合金、超合金
★	鋁	Aluminum
★	鋁合金	Aluminum alloy

★★★ 極佳 ★★ 佳 ★ 尚可

※ 本牌價依市場行情依於折扣優惠，歡迎查詢價格  
The discount will be offered based on current prices. Welcome to check the prices.



● **超微粒鑽頭**  
Micro Grain Coated Drill

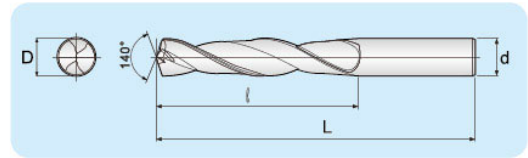

2刃 2 Flutes



**產品特色**

刀刃區近於鏡面，刃口表面光滑，排屑順暢，刀具壽命長，精度也提高。

**FEATURES**

Generally used on wide range of every kind machining. With benefits of fracture resistance and strong edge. Coated TiAlN for maximum heat and wear resistance. Provide maximum hardness and fracture resistance.

型號 Type No	直徑 (D) Diameter	刃長 (l) Flute Length	全長 (L) O. A. L.	柄徑 (d) Shank Dia.	牌價 Price
WDA3.0~3.7	3.0~3.7	22	62	6	1500
WDA3.8~4.7	3.8~4.7	26	66	6	1850
WDA4.8~6.0	4.8~6.0	30	66	6	2250
WDA6.1~7.0	6.1~7.0	38	79	8	2800
WDA7.1~8.0	7.1~8.0	42	79	8	3150
WDA8.1~9.0	8.1~9.0	49	89	10	4100
WDA9.1~10.0	9.1~10.0	49	89	10	4100
WDA10.1~11.0	10.1~11.0	56	102	12	5600
WDA11.1~12.0	11.1~12.0	56	102	12	5600
WDA12.1~13.0	12.1~13.0	61	107	14	8500
WDA13.1~14.0	13.1~14.0	61	107	14	8500
WDA14.1~15.0	14.1~15.0	65	115	16	11100
WDA15.1~16.0	15.1~16.0	65	115	16	11100
WDA16.5	16.5	73	123	18	15000
WDA17.0	17.0	73	123	18	15000
WDA17.5	17.5	73	123	18	15000
WDA18.0	18.0	73	123	18	15000
WDA18.5	18.5	79	131	20	18500
WDA19.0	19.0	79	131	20	18500
WDA19.5	19.5	79	131	20	18500
WDA20.0	20.0	79	131	20	18500

Unit : mm

適用性	被削鋼材	WORK MATERIAL
★★★	鋼、碳鋼	Steel, Carbon steel S15C
★★★	鋼、碳鋼	Steel, Carbon steel S45C
★★	鋼、碳鋼	Hardened S45C 硬化處理
★★	鋼、碳鋼	Steel, Carbon steel S75C
★	鋼、碳鋼	Hardened S75C 硬化處理
★★★	低合金鋼	Low allow steel SCM, SNCM
★★	低合金鋼	Hardened SCM, SNCM 硬化處理
★	低合金鋼	Hardened SCM, SNCM 硬化處理
★	低合金鋼	Hardened SCM, SNCM 硬化處理
★★★	高合金鋼	High allow steel SKD, SKT, SKH
★	高合金鋼	Hardened SKD, SKT, SKH 硬化處理
★★★	不銹鋼	Stainless steel SUS403
★★★	不銹鋼	Stainless steel SUS403
★★★	不銹鋼	Stainless steel SUS304, SUS316
★★	鑄鐵	Cast iron
★★	球墨鑄鐵	Nodular cast iron
★	難削材料	Exotic material 耐熱合金、超合金
★	鋁	Aluminum
★	鋁合金	Aluminum alloy

★★★ 極佳 ★★ 佳 ★ 尚可

鑽頭系列

COATED DRILL SERIES

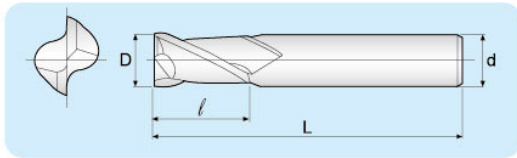

2刃 2 Flutes

● 極超微粒立銑刀  
Super Micro Grain End Mills



型號 Type No	直徑 (D) Diameter	刃長 (ℓ) Flute Length	全長 (L) O. A. L.	柄徑 (d) Shank Dia.	牌價 Price
UGA0101042	1.0	2.5	50	4	550
UGA0151042	1.5	4.0	50	4	550
UGA0201042	2.0	5.0	50	4	550
UGA0251042	2.5	6.5	50	4	550
UGA0301042	3.0	7.5	50	4	550
UGA0351042	3.5	9.0	50	4	550
UGA0401042	4.0	10.0	50	4	550
UGA0451062	4.5	11.5	50	6	635
UGA0501062	5.0	12.5	50	6	635
UGA0551062	5.5	14.0	50	6	635
UGA0601062	6.0	15.0	50	6	635
UGA0652082	6.5	16.5	60	8	1260
UGA0702082	7.0	17.5	60	8	1260
UGA0752082	7.5	19.0	60	8	1260
UGA0802082	8.0	20.0	60	8	1260
UGA0853102	8.5	21.5	75	10	1950
UGA0903102	9.0	22.5	75	10	1950
UGA0953102	9.5	24.0	75	10	1950
UGA1003102	10.0	25.0	75	10	1950
UGA1053122	10.5	27.0	75	12	2750
UGA1103122	11.0	27.5	75	12	2750
UGA1153122	11.5	29.0	75	12	2750
UGA1203122	12.0	30.0	75	12	2750
UGA1304162	13.0	32.5	100	16	6200
UGA1404162	14.0	35.0	100	16	6200
UGA1504162	15.0	37.5	100	16	6200
UGA1604162	16.0	40.0	100	16	6200

Unit : mm

產品特色

1. 適用高速切削極高硬度切割。
2. 針對熱處理鋼材HRC60以上，性能完全發揮。
3. 刀刃趨於近鏡面，刃口表面光滑，排屑順暢，刀具壽命長，精度也提高。

FEATURES

Goof at High Speed and hardness cutting. It may achieve best above HRC60. With benefits of fracture resistance and strong edge.

適用性	被削鋼材	WORK MATERIAL
★★★	鋼、碳鋼	Steel, Carbon steel S15C
★★★	鋼、碳鋼	Steel, Carbon steel S45C
★★	鋼、碳鋼	Hardened S45C 硬化處理
★★	鋼、碳鋼	Steel, Carbon steel S75C
★	鋼、碳鋼	Hardened S75C 硬化處理
★★★	低合金鋼	Low alloy steel SCM, SNCM
★★	低合金鋼	Hardened SCM, SNCM 硬化處理
★	低合金鋼	Hardened SCM, SNCM 硬化處理
★	低合金鋼	Hardened SCM, SNCM 硬化處理
★★★	高合金鋼	High alloy steel SKD, SKT, SKH
★	高合金鋼	Hardened SKD, SKT, SKH 硬化處理
★★★	不銹鋼	Stainless steel SUS403
★★★	不銹鋼	Stainless steel SUS403
★★★	不銹鋼	Stainless steel SUS304, SUS316
★★	鑄鐵	Cast iron
★★	球墨鑄鐵	Nodular cast iron
★	難削材料	Exotic material 耐熱合金、超合金
★	鋁	Aluminum
★	鋁合金	Aluminum alloy

★★★ 極佳 ★★ 佳 ★ 尚可

※ 本牌價依市場行情依於折扣優惠，歡迎查詢價格  
The discount will be offered based on current prices. Welcome to check the prices.



## ●極超微粒立銑刀 Super Micro Grain End Mills

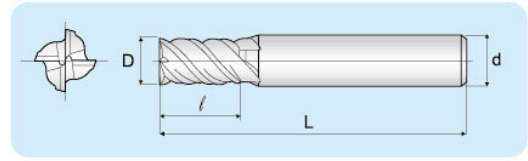

4刃 4 Flutes



極超微粒系列  
SUPER MICRO GRAIN END SERIES

### 產品特色

1. 適用高速切削極高硬度切割。
2. 針對熱處理鋼材HRC60以上，性能完全發揮。
3. 刃刃趨於近鏡面，刃口表面光滑，排屑順暢，刀具壽命長，精度也提高。

### FEATURES

Goof at High Speed and hardness cutting. It may achieve best above HRC60. With benefits of fracture resistance and strong edge.

適用性	被削鋼材	WORK MATERIAL
★★★	鋼、碳鋼	Steel, Carbon steel S15C
★★★	鋼、碳鋼	Steel, Carbon steel S45C
★★	鋼、碳鋼	Hardened S45C 硬化處理
★★	鋼、碳鋼	Steel, Carbon steel S75C
★	鋼、碳鋼	Hardened S75C 硬化處理
★★★	低合金鋼	Low allow steel SCM, SNCM
★★	低合金鋼	Hardened SCM, SNCM 硬化處理
★	低合金鋼	Hardened SCM, SNCM 硬化處理
★	低合金鋼	Hardened SCM, SNCM 硬化處理
★★★	高合金鋼	High allow steel SKD, SKT, SKH
★★	高合金鋼	Hardened SKD, SKT, SKH 硬化處理
★★★	不銹鋼	Stainless steel SUS403
★★★	不銹鋼	Stainless steel SUS403
★★★	不銹鋼	Stainless steel SUS304, SUS316
★★	鑄鐵	Cast iron
★★	球墨鑄鐵	Nodular cast iron
★	難削材料	Exotic material 耐熱合金、超合金
★	鋁	Aluminum
★	鋁合金	Aluminum alloy

★★★ 極佳 ★★ 佳 ★ 尚可

型號 Type No	直徑 (D) Diameter	刃長 (l) Flute Length	全長 (L) O. A. L.	柄徑 (d) Shank Dia.	牌價 Price
UGA0101044	1.0	2.5	50	4	550
UGA0151044	1.5	4.0	50	4	550
UGA0201044	2.0	5.0	50	4	550
UGA0251044	2.5	6.5	50	4	550
UGA0301044	3.0	7.5	50	4	550
UGA0351044	3.5	9.0	50	4	550
UGA0401044	4.0	10.0	50	4	550
UGA0451064	4.5	11.5	50	6	635
UGA0501064	5.0	12.5	50	6	635
UGA0551064	5.5	14.0	50	6	635
UGA0601064	6.0	15.0	50	6	635
UGA0652084	6.5	16.5	60	8	1260
UGA0702084	7.0	17.5	60	8	1260
UGA0752084	7.5	19.0	60	8	1260
UGA0802084	8.0	20.0	60	8	1260
UGA0853104	8.5	21.5	75	10	1950
UGA0903104	9.0	22.5	75	10	1950
UGA0953104	9.5	24.0	75	10	1950
UGA1003104	10.0	25.0	75	10	1950
UGA1053124	10.5	27.0	75	12	2750
UGA1103124	11.0	27.5	75	12	2750
UGA1153124	11.5	29.0	75	12	2750
UGA1203124	12.0	30.0	75	12	2750
UGA1304164	13.0	32.5	100	16	6200
UGA1404164	14.0	35.0	100	16	6200
UGA1504164	15.0	37.5	100	16	6200
UGA1604164	16.0	40.0	100	16	6200

Unit : mm

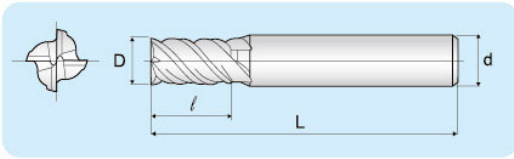

4刃 4 Flutes

●極超微粒立銑刀  
Super Micro Grain End Mills



型號 Type No	直徑 (D) Diameter	刃長 (ℓ) Flute Length	全長 (L) O. A. L.	柄徑 (d) Shank Dia.	牌價 Price
UFA0101044	1.0	2.5	50	4	550
UFA0151044	1.5	4.0	50	4	550
UFA0201044	2.0	5.0	50	4	550
UFA0251044	2.5	6.5	50	4	550
UFA0301044	3.0	7.5	50	4	550
UFA0351044	3.5	9.0	50	4	550
UFA0401044	4.0	10.0	50	4	550
UFA0451064	4.5	11.5	50	6	635
UFA0501064	5.0	12.5	50	6	635
UFA0551064	5.5	14.0	50	6	635
UFA0601064	6.0	15.0	50	6	635
UFA0652084	6.5	16.5	60	8	1260
UFA0702084	7.0	17.5	60	8	1260
UFA0752084	7.5	19.0	60	8	1260
UFA0802084	8.0	20.0	60	8	1260
UFA0853104	8.5	21.5	75	10	1950
UFA0903104	9.0	22.5	75	10	1950
UFA0953104	9.5	24.0	75	10	1950
UFA1003104	10.0	25.0	75	10	1950
UFA1053124	10.5	27.0	75	12	2750
UFA1103124	11.0	27.5	75	12	2750
UFA1153124	11.5	29.0	75	12	2750
UFA1203124	12.0	30.0	75	12	2750
UFA1304164	13.0	32.5	100	16	6200
UFA1404164	14.0	35.0	100	16	6200
UFA1504164	15.0	37.5	100	16	6200
UFA1604164	16.0	40.0	100	16	6200

Unit : mm

產品特色

1. 適用高速切削極高硬度切割。
2. 針對熱處理鋼材HRC60以上，性能完全發揮。
3. 刀刃趨於近鏡面，刃口表面光滑，排屑順暢，刀具壽命長，精度也提高。

FEATURES

Goof at High Speed and hardness cutting. It may achieve best above HRC60. With benefits of fracture resistance and strong edge.

適用性	被削鋼材	WORK MATERIAL
★★★	鋼、碳鋼	Steel, Carbon steel S15C
★★★	鋼、碳鋼	Steel, Carbon steel S45C
★★	鋼、碳鋼	Hardened S45C 硬化處理
★★	鋼、碳鋼	Steel, Carbon steel S75C
★	鋼、碳鋼	Hardened S75C 硬化處理
★★★	低合金鋼	Low allow steel SCM, SNCM
★★	低合金鋼	Hardened SCM, SNCM 硬化處理
★	低合金鋼	Hardened SCM, SNCM 硬化處理
★	低合金鋼	Hardened SCM, SNCM 硬化處理
★★★	高合金鋼	High allow steel SKD, SKT, SKH
★	高合金鋼	Hardened SKD, SKT, SKH 硬化處理
★★★	不銹鋼	Stainless steel SUS403
★★★	不銹鋼	Stainless steel SUS403
★★★	不銹鋼	Stainless steel SUS304, SUS316
★★	鑄鐵	Cast iron
★★	球墨鑄鐵	Nodular cast iron
★	難削材料	Exotic material 耐熱合金、超合金
★	鋁	Aluminum
★	鋁合金	Aluminum alloy

★★★ 極佳 ★★ 佳 ★ 尚可

※本牌價依市場行情依於折扣優惠，歡迎查詢價格  
The discount will be offered based on current prices. Welcome to check the prices.



## ●極超微粒立銑刀 Super Micro Grain End Mills

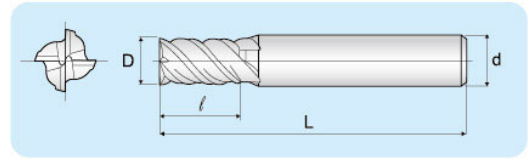

4刃 4 Flutes



極超微粒系列  
SUPER MICRO GRAIN END SERIES

### 產品特色

1. 適用高速切削極高硬度切割。
2. 針對熱處理鋼材HRC60以上，性能完全發揮。
3. 刃刃趨於近鏡面，刃口表面光滑，排屑順暢，刀具壽命長，精度也提高。

### FEATURES

Goof at High Speed and hardness cutting. It may achieve best above HRC60. With benefits of fracture resistance and strong edge.

適用性	被削鋼材	WORK MATERIAL
★★★	鋼、碳鋼	Steel, Carbon steel S15C
★★★	鋼、碳鋼	Steel, Carbon steel S45C
★★	鋼、碳鋼	Hardened S45C 硬化處理
★★	鋼、碳鋼	Steel, Carbon steel S75C
★	鋼、碳鋼	Hardened S75C 硬化處理
★★★	低合金鋼	Low allow steel SCM, SNCM
★★	低合金鋼	Hardened SCM, SNCM 硬化處理
★	低合金鋼	Hardened SCM, SNCM 硬化處理
★	低合金鋼	Hardened SCM, SNCM 硬化處理
★★★	高合金鋼	High allow steel SKD, SKT, SKH
★★	高合金鋼	Hardened SKD, SKT, SKH 硬化處理
★★★	不銹鋼	Stainless steel SUS403
★★★	不銹鋼	Stainless steel SUS403
★★★	不銹鋼	Stainless steel SUS304, SUS316
★★	鑄鐵	Cast iron
★★	球墨鑄鐵	Nodular cast iron
★	難削材料	Exotic material 耐熱合金、超合金
★	鋁	Aluminum
★	鋁合金	Aluminum alloy

★★★ 極佳 ★★ 佳 ★ 尚可

型號 Type No	直徑 (D) Diameter	刃長 (l) Flute Length	全長 (L) O. A. L.	柄徑 (d) Shank Dia.	牌價 Price
UFZ0101044	1.0	2.5	50	4	550
UFZ0151044	1.5	4.0	50	4	550
UFZ0201044	2.0	5.0	50	4	550
UFZ0251044	2.5	6.5	50	4	550
UFZ0301044	3.0	7.5	50	4	550
UFZ0351044	3.5	9.0	50	4	550
UFZ0401044	4.0	10.0	50	4	550
UFZ0451064	4.5	11.5	50	6	635
UFZ0501064	5.0	12.5	50	6	635
UFZ0551064	5.5	14.0	50	6	635
UFZ0601064	6.0	15.0	50	6	635
UFZ0652084	6.5	16.5	60	8	1260
UFZ0702084	7.0	17.5	60	8	1260
UFZ0752084	7.5	19.0	60	8	1260
UFZ0802084	8.0	20.0	60	8	1260
UFZ0853104	8.5	21.5	75	10	1950
UFZ0903104	9.0	22.5	75	10	1950
UFZ0953104	9.5	24.0	75	10	1950
UFZ1003104	10.0	25.0	75	10	1950
UFZ1053124	10.5	27.0	75	12	2750
UFZ1103124	11.0	27.5	75	12	2750
UFZ1153124	11.5	29.0	75	12	2750
UFZ1203124	12.0	30.0	75	12	2750
UFZ1304164	13.0	32.5	100	16	6200
UFZ1404164	14.0	35.0	100	16	6200
UFZ1504164	15.0	37.5	100	16	6200
UFZ1604164	16.0	40.0	100	16	6200

Unit : mm

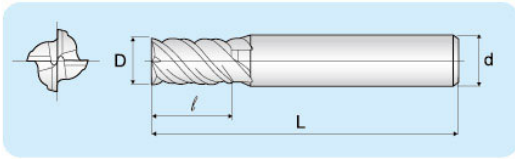

4刃 4 Flutes

●極超微粒立銑刀  
Super Micro Grain End Mills



型號 Type No	直徑 (D) Diameter	刃長 (ℓ) Flute Length	全長 (L) O. A. L.	柄徑 (d) Shank Dia.	牌價 Price
UFB0101044	1.0	2.5	50	4	633
UFB0151044	1.5	4.0	50	4	633
UFB0201044	2.0	5.0	50	4	633
UFB0251044	2.5	6.5	50	4	633
UFB0301044	3.0	7.5	50	4	633
UFB0351044	3.5	9.0	50	4	633
UFB0401044	4.0	10.0	50	4	633
UFB0451064	4.5	11.5	50	6	730
UFB0501064	5.0	12.5	50	6	730
UFB0551064	5.5	14.0	50	6	730
UFB0601064	6.0	15.0	50	6	730
UFB0652084	6.5	16.5	60	8	1449
UFB0702084	7.0	17.5	60	8	1449
UFB0752084	7.5	19.0	60	8	1449
UFB0802084	8.0	20.0	60	8	1449
UFB0853104	8.5	21.5	75	10	2243
UFB0903104	9.0	22.5	75	10	2243
UFB0953104	9.5	24.0	75	10	2243
UFB1003104	10.0	25.0	75	10	2243
UFB1053124	10.5	27.0	75	12	3163
UFB1103124	11.0	27.5	75	12	3163
UFB1153124	11.5	29.0	75	12	3163
UFB1203124	12.0	30.0	75	12	3163
UFB1304164	13.0	32.5	100	16	7130
UFB1404164	14.0	35.0	100	16	7130
UFB1504164	15.0	37.5	100	16	7130
UFB1604164	16.0	40.0	100	16	7130

Unit : mm

產品特色

1. 適用高速切削極高硬度切割。
2. 針對熱處理鋼材HRC60以上，性能完全發揮。
3. 刀刃趨於近鏡面，刃口表面光滑，排屑順暢，刀具壽命長，精度也提高。

FEATURES

Goof at High Speed and hardness cutting. It may achieve best above HRC60. With benefits of fracture resistance and strong edge.

適用性	被削鋼材	WORK MATERIAL
★★★	鋼、碳鋼	Steel, Carbon steel S15C
★★★	鋼、碳鋼	Steel, Carbon steel S45C
★★	鋼、碳鋼	Hardened S45C 硬化處理
★★	鋼、碳鋼	Steel, Carbon steel S75C
★	鋼、碳鋼	Hardened S75C 硬化處理
★★★	低合金鋼	Low allow steel SCM, SNCM
★★	低合金鋼	Hardened SCM, SNCM 硬化處理
★	低合金鋼	Hardened SCM, SNCM 硬化處理
★	低合金鋼	Hardened SCM, SNCM 硬化處理
★★★	高合金鋼	High allow steel SKD, SKT, SKH
★	高合金鋼	Hardened SKD, SKT, SKH 硬化處理
★★★	不銹鋼	Stainless steel SUS403
★★★	不銹鋼	Stainless steel SUS403
★★★	不銹鋼	Stainless steel SUS304, SUS316
★★	鑄鐵	Cast iron
★★	球墨鑄鐵	Nodular cast iron
★	難削材料	Exotic material 耐熱合金、超合金
★	鋁	Aluminum
★	鋁合金	Aluminum alloy

★★★ 極佳 ★★ 佳 ★ 尚可

※本牌價依市場行情依於折扣優惠，歡迎查詢價格  
The discount will be offered based on current prices. Welcome to check the prices. 50



## ●極超微粒立銑刀 Super Micro Grain End Mills

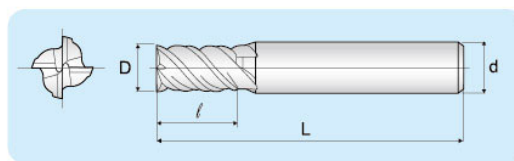

4刃 4 Flutes



極超微粒系列

SUPER MICRO GRAIN END SERIES

**產品特色**

1. 適用高速切削極高硬度切割。
2. 針對熱處理鋼材HRC60以上，性能完全發揮。
3. 刃刃趨於近鏡面，刃口表面光滑，排屑順暢，刀具壽命長，精度也提高。

**FEATURES**

Good at High Speed and hardness cutting. It may achieve best above HRC60. With benefits of fracture resistance and strong edge.

適用性	被削鋼材	WORK MATERIAL
	鋼、碳鋼	Steel, Carbon steel S15C
	鋼、碳鋼	Steel, Carbon steel S45C
	鋼、碳鋼	Hardened S45C 硬化處理
	鋼、碳鋼	Steel, Carbon steel S75C
	鋼、碳鋼	Hardened S75C 硬化處理
	低合金鋼	Low allow steel SCM, SNCM
	低合金鋼	Hardened SCM, SNCM 硬化處理
	低合金鋼	Hardened SCM, SNCM 硬化處理
	低合金鋼	Hardened SCM, SNCM 硬化處理
	高合金鋼	High allow steel SKD, SKT, SKH
	高合金鋼	Hardened SKD, SKT, SKH 硬化處理
	不銹鋼	Stainless steel SUS403
	不銹鋼	Stainless steel SUS403
	不銹鋼	Stainless steel SUS304, SUS316
	鑄鐵	Cast iron
★★★	球墨鑄鐵	Nodular cast iron
	難削材料	Exotic material 耐熱合金、超合金
	鋁	Aluminum
	鋁合金	Aluminum alloy
★★★	非金屬材料	
★★★	碳纖維	
★★★	玻璃纖維	

★★★極佳 ★★佳 ★尚可

型號 Type No	直徑 (D) Diameter	刃長 (ℓ) Flute Length	全長 (L) O. A. L.	柄徑 (d) Shank Dia.	牌價 Price
UFT0101044	1.0	2.5	50	4	1100
UFT0151044	1.5	4.0	50	4	1100
UFT0201044	2.0	5.0	50	4	1100
UFT0251044	2.5	6.5	50	4	1100
UFT0301044	3.0	7.5	50	4	1100
UFT0351044	3.5	9.0	50	4	1100
UFT0401044	4.0	10.0	50	4	1100
UFT0451064	4.5	11.5	50	6	1270
UFT0501064	5.0	12.5	50	6	1270
UFT0551064	5.5	14.0	50	6	1270
UFT0601064	6.0	15.0	50	6	1270
UFT0652084	6.5	16.5	60	8	2520
UFT0702084	7.0	17.5	60	8	2520
UFT0752084	7.5	19.0	60	8	2520
UFT0802084	8.0	20.0	60	8	2520
UFT0853104	8.5	21.5	75	10	3900
UFT0903104	9.0	22.5	75	10	3900
UFT0953104	9.5	24.0	75	10	3900
UFT1003104	10.0	25.0	75	10	3900
UFT1053124	10.5	27.0	75	12	5500
UFT1103124	11.0	27.5	75	12	5500
UFT1153124	11.5	29.0	75	12	5500
UFT1203124	12.0	30.0	75	12	5500
UFT1304164	13.0	32.5	100	16	12400
UFT1404164	14.0	35.0	100	16	12400
UFT1504164	15.0	37.5	100	16	12400
UFT1604164	16.0	40.0	100	16	12400

Unit : mm

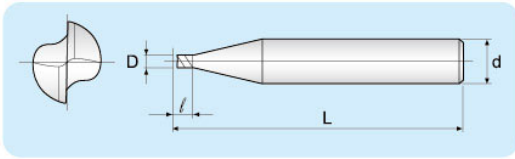

2刃 2 Flutes

●極超微粒微小徑立銑刀  
Super Micro Diameter End Mills



型號 Type No	直徑 (D) Diameter	刃長 (ℓ) Flute Length	全長 (L) O. A. L.	柄徑 (d) Shank Dia.	牌價 Price
UMGA0021042	0.2	0.4	50	4	1500
UMGA0031042	0.3	0.6	50	4	1300
UMGA0041042	0.4	0.8	50	4	1300
UMGA0051042	0.5	1.0	50	4	1100
UMGA0061042	0.6	1.2	50	4	1100
UMGA0071042	0.7	1.4	50	4	1100
UMGA0081042	0.8	1.6	50	4	1100
UMGA0091042	0.9	1.8	50	4	1100
UMGA0101042	1.0	2.5	50	4	550
UMGA0111042	1.1	3.0	50	4	780
UMGA0121042	1.2	3.0	50	4	780
UMGA0130142	1.3	3.5	50	4	780
UMGA0141042	1.4	3.5	50	4	780
UMGA0151042	1.5	4.0	50	4	550
UMGA0161042	1.6	4.0	50	4	750
UMGA0171042	1.7	4.5	50	4	750
UMGA0181042	1.8	4.5	50	4	750
UMGA0191042	1.9	5.0	50	4	750
UMGA0201042	2.0	5.0	50	4	550
UMGA0211042	2.1	5.5	50	4	750
UMGA0221042	2.2	5.5	50	4	750
UMGA0221042	2.3	6.0	50	4	750
UMGA0241042	2.4	6.0	50	4	750
UMGA0251042	2.5	6.5	50	4	550
UMGA0261042	2.6	6.5	50	4	750
UMGA0271042	2.7	7.0	50	4	750
UMGA0281042	2.8	7.0	50	4	750
UMGA0291042	2.9	7.5	50	4	750
UMGA0301042	3.0	7.5	50	4	550

Unit : mm

產品特色

1. 適用高速切削極高硬度切割。
2. 針對熱處理鋼材HRC60以上，性能完全發揮。
3. 刀刃趨於近鏡面，刃口表面光滑，排屑順暢，刀具壽命長，精度也提高。

FEATURES

Goof at High Speed and hardness cutting. It may achieve best above HRC60. With benefits of fracture resistance and strong edge.

適用性	被削鋼材	WORK MATERIAL
★★★	鋼、碳鋼	Steel, Carbon steel S15C
★★★	鋼、碳鋼	Steel, Carbon steel S45C
★★	鋼、碳鋼	Hardened S45C 硬化處理
★★	鋼、碳鋼	Steel, Carbon steel S75C
★	鋼、碳鋼	Hardened S75C 硬化處理
★★★	低合金鋼	Low alloy steel SCM, SNCM
★★	低合金鋼	Hardened SCM, SNCM 硬化處理
★	低合金鋼	Hardened SCM, SNCM 硬化處理
★	低合金鋼	Hardened SCM, SNCM 硬化處理
★★★	高合金鋼	High alloy steel SKD, SKT, SKH
★	高合金鋼	Hardened SKD, SKT, SKH 硬化處理
★★★	不銹鋼	Stainless steel SUS403
★★★	不銹鋼	Stainless steel SUS403
★★★	不銹鋼	Stainless steel SUS304, SUS316
★★	鑄鐵	Cast iron
★★	球墨鑄鐵	Nodular cast iron
★	難削材料	Exotic material 耐熱合金、超合金
★	鋁	Aluminum
★	鋁合金	Aluminum alloy

★★★ 極佳 ★★ 佳 ★ 尚可

※本牌價依市場行情依於折扣優惠，歡迎查詢價格  
The discount will be offered based on current prices. Welcome to check the prices.



● **極超微粒高硬度專用立銑刀**  
**Super Micro Grain High Hardness End Mills**

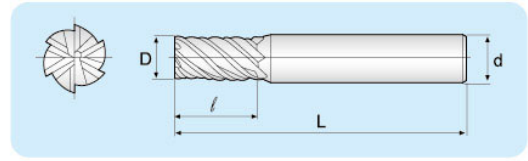

6刃 6 Flutes



**產品特色**

1. 適用高速洩消極高硬度切割。
2. 針對熱處理鋼材HRC60以上，性能完全發揮。
3. 刃刃趨於近鏡面，刃口表面光滑，排屑順暢，刀具壽命長，精度也提高。

**FEATURES**

Goof at High Speed and hardness cutting. It may achieve best above HRC60. With benefits of fracture resistance and strong edge.

型號 Type No	直徑 (D) Diameter	刃長(ℓ) Flute Length	全長(L) O. A. L.	柄徑(d) Shank Dia.	牌價 Price
UVA0201046	2.0	5.0	50	4	625
UVA0301046	3.0	7.5	50	4	625
UVA0401046	4.0	10.0	50	4	625
UVA0501066	5.0	12.5	50	6	710
UVA0601066	6.0	15.0	50	6	710
UVA0603066	6.0	26.0	75	6	1065
UVA0802086	8.0	20.0	60	8	1420
UVA0804086	8.0	35.0	100	8	2370
UVA1003106	10.0	25.0	75	10	2370
UVA1004106	10.0	40.0	100	10	3135
UVA1203126	12.0	30.0	75	12	2955
UVA1204126	12.0	50.0	100	12	3940
UVA1605166	16.0	50.0	150	16	12520
UVA2006206	20.0	50.0	150	20	17440

Unit : mm

適用性	被削鋼材	WORK MATERIAL
★★★	鋼、碳鋼	Steel, Carbon steel S15C
★★★	鋼、碳鋼	Steel, Carbon steel S45C
★★	鋼、碳鋼	Hardened S45C 硬化處理
★★	鋼、碳鋼	Steel, Carbon steel S75C
★	鋼、碳鋼	Hardened S75C 硬化處理
★★★	低合金鋼	Low allow steel SCM, SNCM
★★	低合金鋼	Hardened SCM, SNCM 硬化處理
★	低合金鋼	Hardened SCM, SNCM 硬化處理
★	低合金鋼	Hardened SCM, SNCM 硬化處理
★★★	高合金鋼	High allow steel SKD, SKT, SKH
★	高合金鋼	Hardened SKD,SKT,SKH 硬化處理
★★★	不銹鋼	Stainless steel SUS403
★★★	不銹鋼	Stainless steel SUS403
★★★	不銹鋼	Stainless steel SUS304, SUS316
★★	鑄鐵	Cast iron
★★	球墨鑄鐵	Nodular cast iron
★	難削材料	Exotic material 耐熱合金、超合金
★	鋁	Aluminum
★	鋁合金	Aluminum alloy

★★★ 極佳 ★★ 佳 ★ 尚可

極超微粒系列

SUPER MICRO GRAIN END SERIES

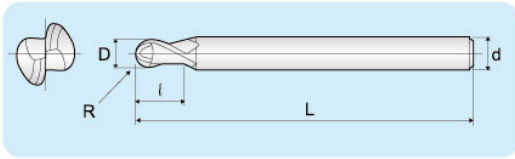

2刃 2 Flutes

## ● 極超微粒圓頭立銑刀 Super Micro Grain Ball End Mills



型號 Type No	直徑 (D) Diameter	刃長 (ℓ) Flute Length	全長 (L) O. A. L.	柄徑 (d) Shank Dia.	牌價 Price
UBA0041042	0.2 R	0.8	50	4	1350
UBA0061042	0.3 R	1.2	50	4	1350
UBA0081042	0.4 R	1.6	50	4	1350
UBA0101042	0.5 R	2.0	50	4	600
UBA0151042	0.75 R	3.0	50	4	600
UBA0201042	1.0 R	4.0	50	4	600
UBA0251042	1.25 R	5.0	50	4	600
UBA0301042	1.5 R	6.0	50	4	600
UBA0401042	2.0 R	8.0	50	4	600
UBA0601042	3.0 R	12.0	50	6	725
UBA0802082	4.0 R	16.0	60	8	1430
UBA1003102	5.0 R	20.0	75	10	2100
UBA1203122	6.0 R	24.0	75	12	2950

Unit : mm

### 產品特色

1. 適用高速切削極高硬度切割。
2. 針對熱處理鋼材HRC60以上，性能完全發揮。
3. 刀刃趨於近鏡面，刃口表面光滑，排屑順暢，刀具壽命長，精度也提高。

### FEATURES

Goof at High Speed and hardness cutting. It may achieve best above HRC60. With benefits of fracture resistance and strong edge.

適用性	被削鋼材	WORK MATERIAL
★★★★	鋼、碳鋼	Steel, Carbon steel S15C
★★★★	鋼、碳鋼	Steel, Carbon steel S45C
★★★	鋼、碳鋼	Hardened S45C 硬化處理
★★★	鋼、碳鋼	Hardened S75C
★	鋼、碳鋼	Hardened S75C 硬化處理
★★★★	低合金鋼	Low allow steel SCM, SNCM
★★★	低合金鋼	Hardened SCM, SNCM 硬化處理
★	低合金鋼	Hardened SCM, SNCM 硬化處理
★	低合金鋼	Hardened SCM, SNCM 硬化處理
★★★★	高合金鋼	High allow steel SKD, SKT, SKH
★	高合金鋼	Hardened SKD, SKT, SKH 硬化處理
★★★★	不銹鋼	Stainless steel SUS403
★★★★	不銹鋼	Stainless steel SUS403
★★★★	不銹鋼	Stainless steel SUS304, SUS316
★★★	鑄鐵	Cast iron
★★★	球墨鑄鐵	Nodular cast iron
★	難削材料	Exotic material 耐熱合金、超合金
★	鋁	Aluminum
★	鋁合金	Aluminum alloy

★★★★ 極佳 ★★ 佳 ★ 尚可

※ 本牌價依市場行情依於折扣優惠，歡迎查詢價格  
The discount will be offered based on current prices. Welcome to check the prices. 54



● **極超微粒圓頭立銑刀**  
Super Micro Grain Ball End Mills

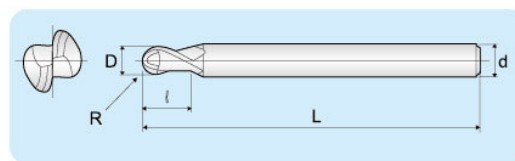

2刃 2 Flutes



**產品特色**

1. 適用高速切削極高硬度切割。
2. 針對熱處理鋼材HRC60以上，性能完全發揮。
3. 刀刃趨於近鏡面，刃口表面光滑，排屑順暢，刀具壽命長，精度也提高。

**FEATURES**

Goof at High Speed and hardness cutting. It may achieve best above HRC60. With benefits of fracture resistance and strong edge.

型號 Type No	直徑 (D) Diameter	刃長 (ℓ) Flute Length	全長 (L) O. A. L.	柄徑 (d) Shank Dia.	牌價 Price
UBZ0041042	0.2 R	0.8	50	4	1350
UBZ0061042	0.3 R	1.2	50	4	1350
UBZ0081042	0.4 R	1.6	50	4	1350
UBZ0101042	0.5 R	2.0	50	4	600
UBZ0151042	0.75 R	3.0	50	4	600
UBZ0201042	1.0 R	4.0	50	4	600
UBZ0251042	1.25 R	5.0	50	4	600
UBZ0301042	1.5 R	6.0	50	4	600
UBZ0401042	2.0 R	8.0	50	4	600
UBZ0601042	3.0 R	12.0	50	6	725
UBZ0802082	4.0 R	16.0	60	8	1430
UBZ1003102	5.0 R	20.0	75	10	2100
UBZ1203122	6.0 R	24.0	75	12	2950

Unit : mm

適用性	被削鋼材	WORK MATERIAL
★★★★	鋼、碳鋼	Steel, Carbon steel S15C
★★★★	鋼、碳鋼	Steel, Carbon steel S45C
★★	鋼、碳鋼	Hardened S45C 硬化處理
★★	鋼、碳鋼	Steel, Carbon steel S75C
★	鋼、碳鋼	Hardened S75C 硬化處理
★★★★	低合金鋼	Low allow steel SCM, SNCM
★★	低合金鋼	Hardened SCM, SNCM 硬化處理
★	低合金鋼	Hardened SCM, SNCM 硬化處理
★	低合金鋼	Hardened SCM, SNCM 硬化處理
★★★★	高合金鋼	High allow steel SKD, SKT, SKH
★	高合金鋼	Hardened SKD,SKT,SKH 硬化處理
★★★★	不銹鋼	Stainless steel SUS403
★★★★	不銹鋼	Stainless steel SUS403
★★★★	不銹鋼	Stainless steel SUS304, SUS316
★★	鑄鐵	Cast iron
★★	球墨鑄鐵	Nodular cast iron
★	難削材料	Exotic material 耐熱合金、超合金
★	鋁	Aluminum
★	鋁合金	Aluminum alloy

★★★★ 極佳 ★★ 佳 ★ 尚可

極超微粒系列

SUPER MICRO GRAIN END SERIES

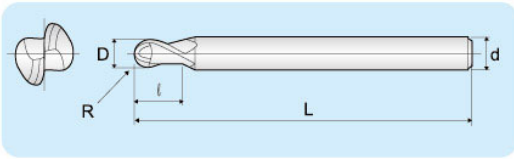

2刃 2 Flutes

● 極超微粒圓頭立銑刀  
Super Micro Grain Ball End Mills



型號 Type No	直徑 (D) Diameter	刃長 (L) Flute Length	全長 (L) O. A. L.	柄徑 (d) Shank Dia.	牌價 Price
UBB0041042	0.2 R	0.8	50	4	1553
UBB0061042	0.3 R	1.2	50	4	1553
UBB0081042	0.4 R	1.6	50	4	1553
UBB0101042	0.5 R	2.0	50	4	690
UBB0151042	0.75 R	3.0	50	4	690
UBB0201042	1.0 R	4.0	50	4	690
UBB0251042	1.25 R	5.0	50	4	690
UBB0301042	1.5 R	6.0	50	4	690
UBB0401042	2.0 R	8.0	50	4	690
UBB0601042	3.0 R	12.0	50	6	834
UBB0802082	4.0 R	16.0	60	8	1645
UBB1003102	5.0 R	20.0	75	10	2145
UBB1203122	6.0 R	24.0	75	12	3393

Unit : mm

產品特色

1. 適用高速切削極高硬度切割。
2. 針對熱處理鋼材HRC60以上，性能完全發揮。
3. 刀刃趨於近鏡面，刃口表面光滑，排屑順暢，刀具壽命長，精度也提高。

FEATURES

Goof at High Speed and hardness cutting. It may achieve best above HRC60. With benefits of fracture resistance and strong edge.

適用性	被削鋼材	WORK MATERIAL
★★★	鋼、碳鋼	Steel, Carbon steel S15C
★★★	鋼、碳鋼	Steel, Carbon steel S45C
★★	鋼、碳鋼	Hardened S45C 硬化處理
★★	鋼、碳鋼	Steel, Carbon steel S75C
★	鋼、碳鋼	Hardened S75C 硬化處理
★★★	低合金鋼	Low allow steel SCM, SNCM
★★	低合金鋼	Hardened SCM, SNCM 硬化處理
★	低合金鋼	Hardened SCM, SNCM 硬化處理
★	低合金鋼	Hardened SCM, SNCM 硬化處理
★★★	高合金鋼	High allow steel SKD, SKT, SKH
★	高合金鋼	Hardened SKD, SKT, SKH 硬化處理
★★★	不銹鋼	Stainless steel SUS403
★★★	不銹鋼	Stainless steel SUS403
★★★	不銹鋼	Stainless steel SUS304, SUS316
★★	鑄鐵	Cast iron
★★	球墨鑄鐵	Nodular cast iron
★	難削材料	Exotic material 耐熱合金、超合金
★	鋁	Aluminium
★	鋁合金	Aluminum alloy

★★★ 極佳 ★★ 佳 ★ 尚可



## ● 極超微粒圓隅立銑刀 Super Micro Grain End Mills

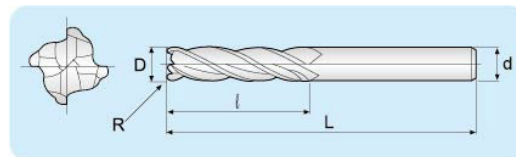

4刃 4 Flutes



### 產品特色

1. 使用圓隅角立銑刀可提高進給速率，一次加工完成，增加生產效能降低成本。
2. 圓隅角的設計比一般立銑刀更耐磨耗，延長刀具壽命。
3. 應用於模具加工，適用於一般鋼材、難切削材質，如不銹鋼、鎳合金、調質鋼、NAK55、NAK80、高合金鋼等。

### FEATURES

The corner radius design strengthens the end mill by reducing chipping, providing longer tool life. Corner more material faster, improve productivity and reduce cost.

適用性	被削鋼材	WORK MATERIAL
★★★	鋼、碳鋼	Steel, Carbon steel S15C
★★★	鋼、碳鋼	Steel, Carbon steel S45C
★★	鋼、碳鋼	Hardened S45C 硬化處理
★★	鋼、碳鋼	Steel, Carbon steel S75C
★	鋼、碳鋼	Hardened S75C 硬化處理
★★★	低合金鋼	Low allow steel SCM, SNCM
★★	低合金鋼	Hardened SCM, SNCM 硬化處理
★	低合金鋼	Hardened SCM, SNCM 硬化處理
★	低合金鋼	Hardened SCM, SNCM 硬化處理
★★★	高合金鋼	High allow steel SKD, SKT, SKH
★★	高合金鋼	Hardened SKD, SKT, SKH 硬化處理
★★★	不銹鋼	Stainless steel SUS403
★★★	不銹鋼	Stainless steel SUS403
★★★	不銹鋼	Stainless steel SUS304, SUS316
★★	鑄鐵	Cast iron
★★	球墨鑄鐵	Nodular cast iron
★	難削材料	Exotic material 耐熱合金、超合金
★	鋁	Aluminum
★	鋁合金	Aluminum alloy

★★★ 極佳 ★★ 佳 ★ 尚可

型號 Type No	直徑 (D) Diameter	刃長 (L) Flute Length	R 角 Corner R	全長 (L) O. A. L.	柄徑 (d) Shank Dia.	牌價 Price
URA03051034	3	4.0	0.5	50	3	600
URA03101034	3	4.0	1.0	50	3	600
URA04051044	4	5.0	0.5	50	4	600
URA04101044	4	5.0	1.0	50	4	600
URA06051064	6	7.5	0.5	50	6	725
URA06101064	6	7.5	1.0	50	6	725
URA06151064	6	7.5	1.5	50	6	725
URA06201064	6	7.5	2.0	50	6	725
URA08052084	8	10.0	0.5	60	8	1430
URA08102084	8	10.0	1.0	60	8	1430
URA08152084	8	10.0	1.5	60	8	1430
URA08202084	8	10.0	2.0	60	8	1430
URA08252084	8	10.0	2.5	60	8	1430
URA08302084	8	10.0	3.0	60	8	1430
URA10053104	10	12.0	0.5	75	10	2110
URA10103104	10	12.0	1.0	75	10	2110
URA10153104	10	12.0	1.5	75	10	2110
URA10203104	10	12.0	2.0	75	10	2110
URA10253104	10	12.0	2.5	75	10	2110
URA10303104	10	12.0	3.0	75	10	2110
URA12053124	12	14.5	0.5	75	12	2950
URA12103124	12	14.5	1.0	75	12	2950
URA12153124	12	14.5	1.5	75	12	2950
URA12203124	12	14.5	2.0	75	12	2950
URA12253124	12	14.5	2.5	75	12	2950
URA12303124	12	14.5	3.0	75	12	2950

Unit : mm

● 焊刃鎢鋼刀具系列 Milling Cutter Series



焊接式鎢鋼標準刃直柄精銑刀  
Brazed Carbide Spiral End Mill



焊接式鎢鋼T型鍵槽銑刀  
Saggered Tooth-Slot Milling Cutter

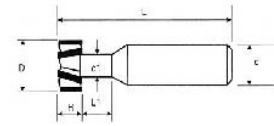

焊接式鎢鋼鳩尾槽銑刀  
Dovetail Milling Cutter

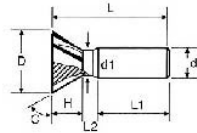

焊接式鎢鋼標準刃直柄精銑刀  
Brazed Carbide Spiral End Mill

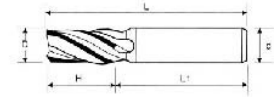

鎢鋼倒角刀  
Angle Milling Cutter

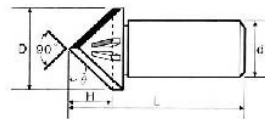

鎢鋼銑刀  
Milling Cutter

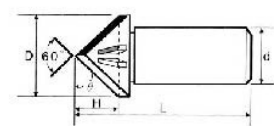

鳩尾槽筒狀銑刀  
Dovetail Milling Cutter

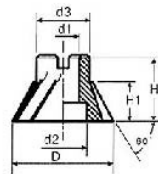

鎢鋼銑刀  
Milling Cutter



焊刃筒仔刀  
Carbide Spial End Mill

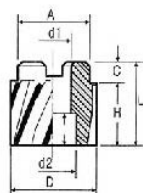

鎢鋼側銑刀  
Brazed Side Milling Cutter



● 捨棄式銑刀系列 Disposable Milling Cutter Series

捨棄式銑刀系列  
DISPOSABLE MILLING CUTTER SERIES



圓刃端銑刀  
End Mills(W) Indexable Inserts

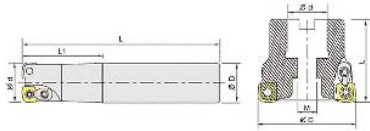

ED圓刃端銑刀  
End Mills(W) ED Indexable Inserts

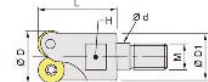

RD圓刃端銑刀  
End Mills(W) ED Indexable Inserts



RD圓刃端銑刀  
End Mills(W) ED Indexable Inserts

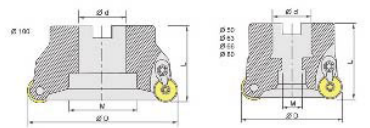

RD圓刃端銑刀  
End Mills(W) ED Indexable Inserts

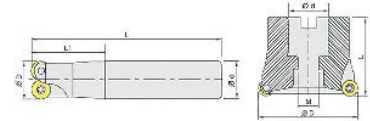

RD圓刃端銑刀  
End Mills(W) ED Indexable Inserts

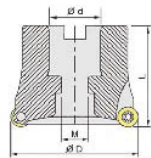

TR圓刃端銑刀  
End Mills(W) ED Indexable Inserts

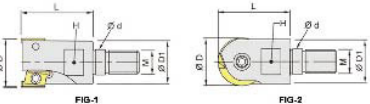

捨棄式刀刃直角端銑刀  
Shoulder/Cutting End Mills(W) Throw-Away inserts

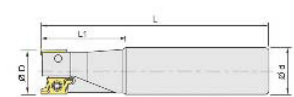

捨棄式刀刃直角端銑刀  
Shoulder/Cutting End Mills(W) Throw-Away inserts

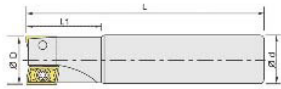

捨棄式刀刃直角端銑刀  
Shoulder/Cutting End Mills(W) Throw-Away inserts

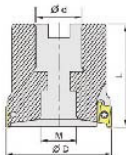

捨棄式刀刃直角端銑刀  
Shoulder/Cutting End Mills(W) Throw-Away inserts

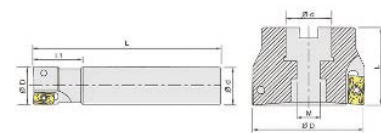

捨棄式刀刃直角端銑刀  
Shoulder/Cutting End Mills(W) Throw-Away inserts

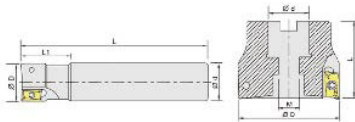

捨棄式刀刃直角端銑刀  
Shoulder/Cutting End Mills(W) Throw-Away inserts



捨棄式刀刃直角端銑刀  
Shoulder/Cutting End Mills(W) Throw-Away inserts

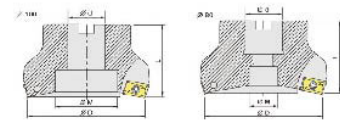

捨棄式面銑刀  
Face Milling Cutters

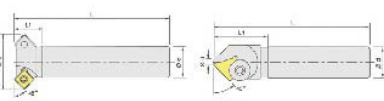

捨棄式刀刃倒角刀  
Chamfer Mills(W) Throw-Away Inserts

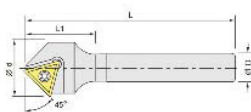

捨棄式刀刃倒角刀  
Chamfer Mills(W) Throw-Away Inserts

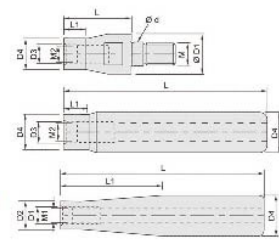

MD連接式刀桿  
Extension Adapter

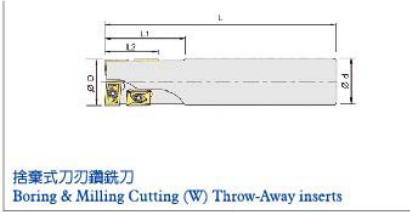

捨棄式刀刃鑽銑刀  
Boring & Milling Cutting (W) Throw-Away inserts



捨棄式刀刃鑽銑刀  
Boring & Milling Cutting (W) Throw-Away inserts

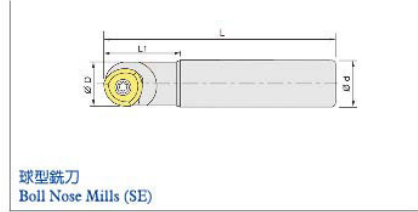

球型銑刀  
Ball Nose Mills (SE)

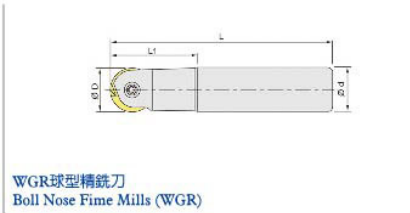

WGR球型精銑刀  
Ball Nose Fine Mills (WGR)

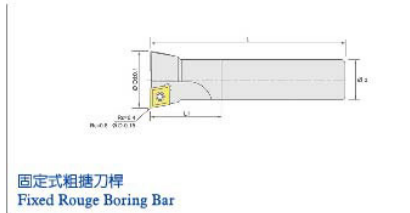

固定式粗磨刀桿  
Fixed Rouge Boring Bar

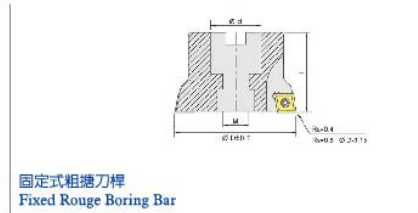

固定式粗磨刀桿  
Fixed Rouge Boring Bar

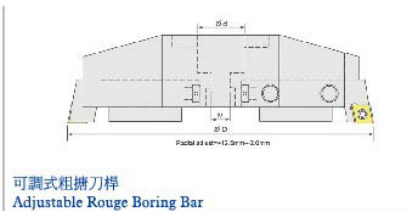

可調式粗磨刀桿  
Adjustable Rouge Boring Bar



捨棄式刀刃擴孔刀架  
Boring Bar(W) Throw-Away Inserts



捨棄式刀刃擴孔刀架  
Boring Bar(W) Throw-Away Inserts

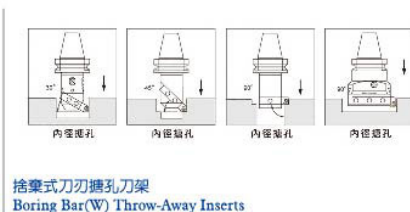

捨棄式刀刃擴孔刀架  
Boring Bar(W) Throw-Away Inserts



捨棄式刀刃擴孔刀架  
Boring Bar(W) Throw-Away Inserts

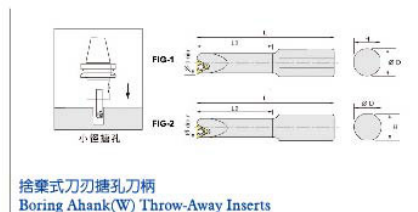

捨棄式刀刃擴孔刀柄  
Boring Ahank(W) Throw-Away Inserts

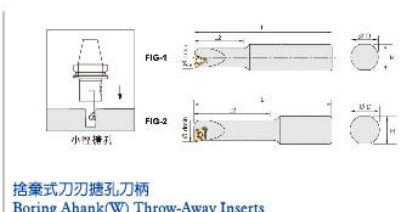

捨棄式刀刃擴孔刀柄  
Boring Ahank(W) Throw-Away Inserts

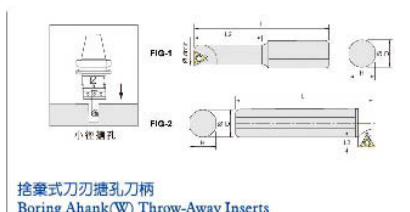

捨棄式刀刃擴孔刀柄  
Boring Ahank(W) Throw-Away Inserts

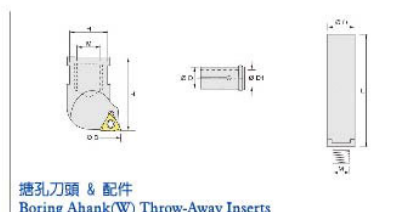

擴孔刀頭 & 配件  
Boring Ahank(W) Throw-Away Inserts

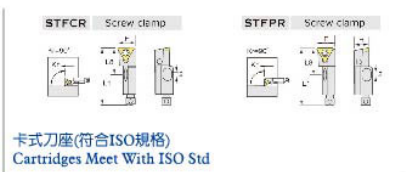

卡式刀座(符合ISO規格)  
Cartridges Meet With ISO Std



卡式刀座(符合ISO規格)  
Cartridges Meet With ISO Std



卡式刀座(符合ISO規格)  
Cartridges Meet With ISO Std

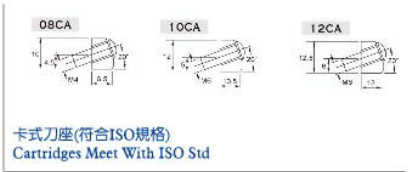

卡式刀座(符合ISO規格)  
Cartridges Meet With ISO Std

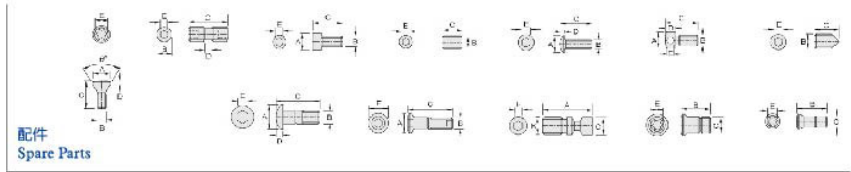

配件  
Spare Parts



● 捨棄式車刀具系列 Disposable Lathe Cutter Series

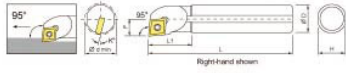

SCLC-SCLP

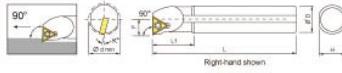

STFC/STFP

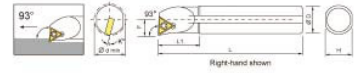

STUC/STIP

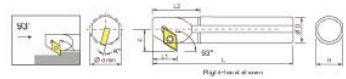

SDZC

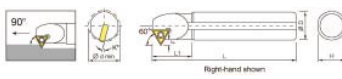

STWC

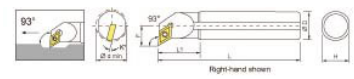

SDUC

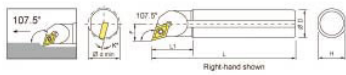

SDQC 107.5°

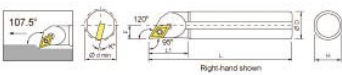

SDJC 107.5°

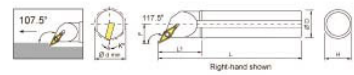

SVQC

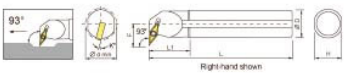

SVUC

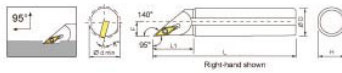

SVJC 95°

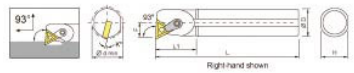

MTUN 93°

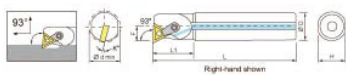

MTUN-A 93°

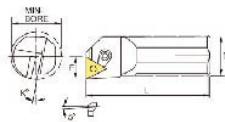

MTFN 90°

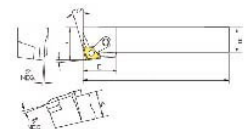

MCKN 75°

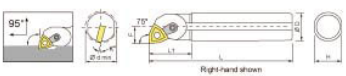

MWLN 95°

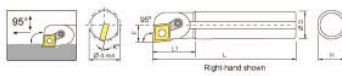

MCLN 95°

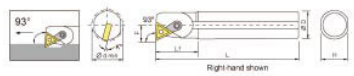

MDUN 93°

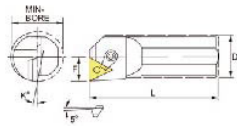

CTFP 90°

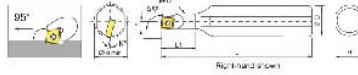

SCLC

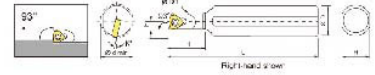

SWUB

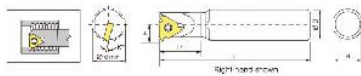

SNR

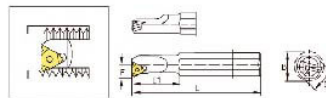

SINR/L

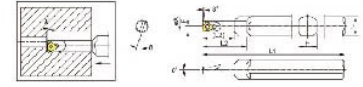

SWUBR

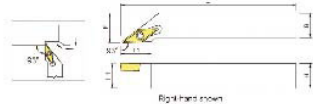

SVJC 93°

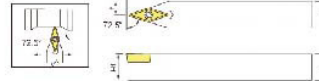

SVVC

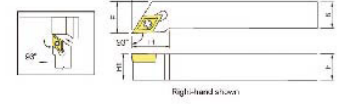

SDJC 93°

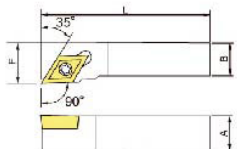

SDAC

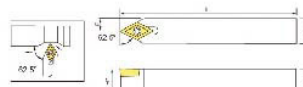

SDNCN

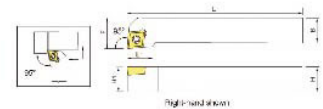

SLCL

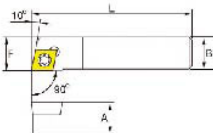

SCAC

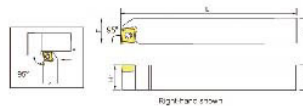

SCLC-N

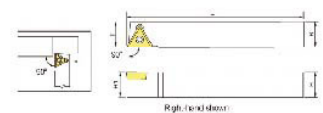

STAC-N

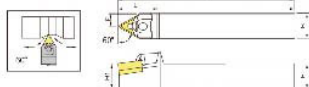

MTEN 60°

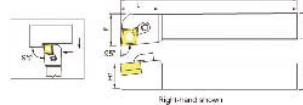

MCLN 95°

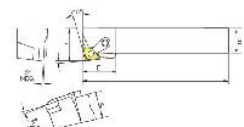

MCKN 75°



● 捨棄式車刀具系列 Disposable Lathe Cutter Series

捨棄式車刀具系列  
DISPOSABLE LATHE CUTTER SERIES

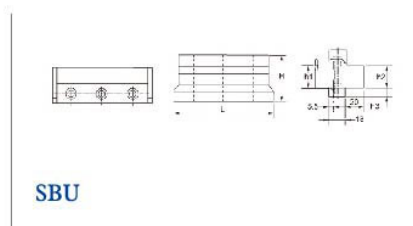
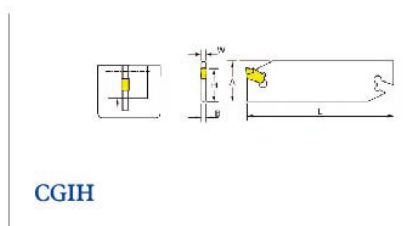
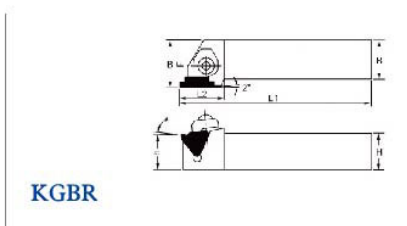
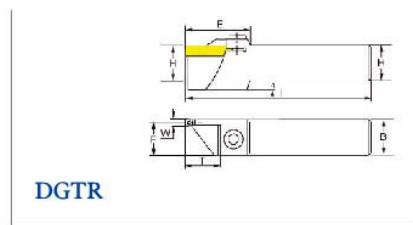
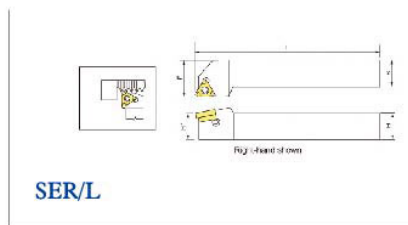
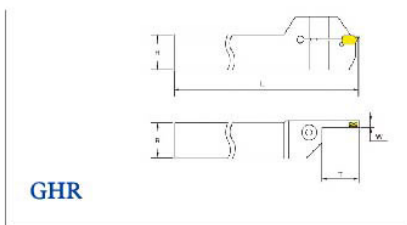
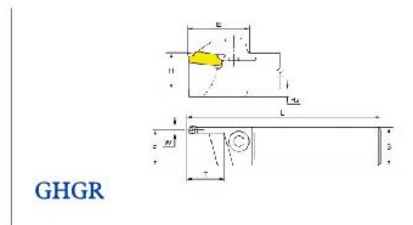
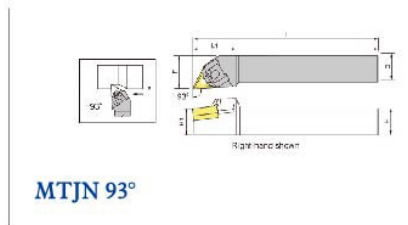
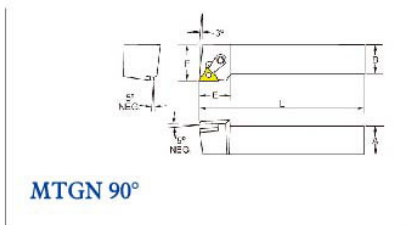
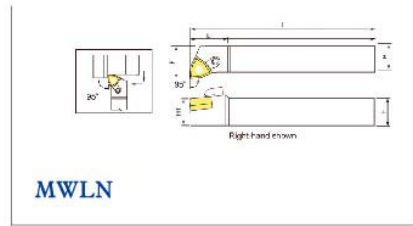
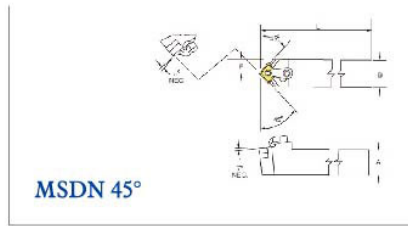
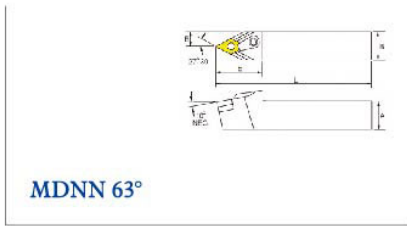
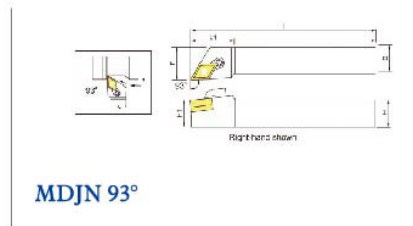
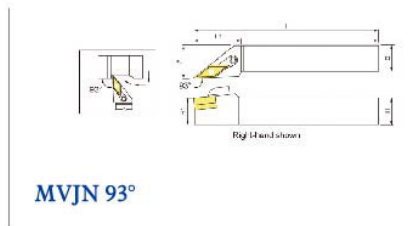
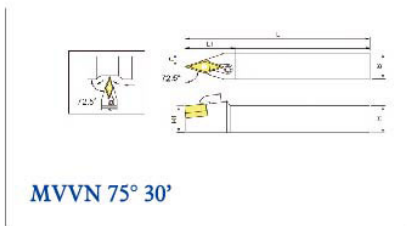
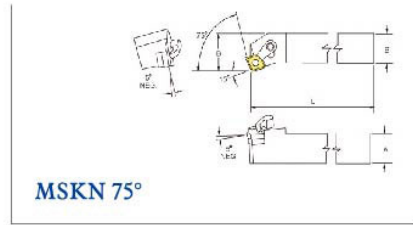
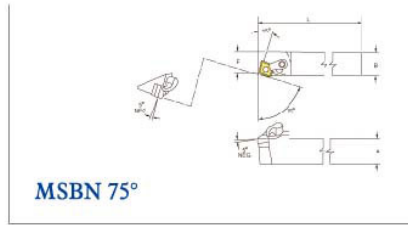
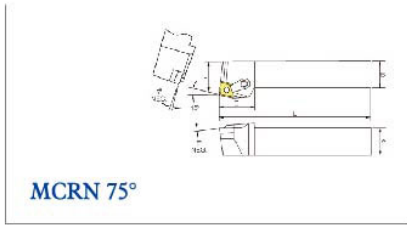

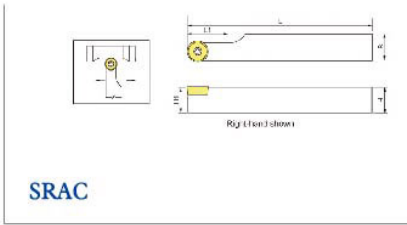

SRAC

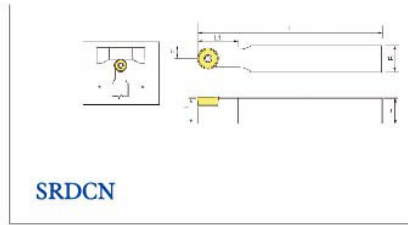

SRDCN

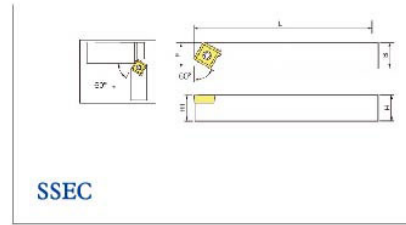

SSEC

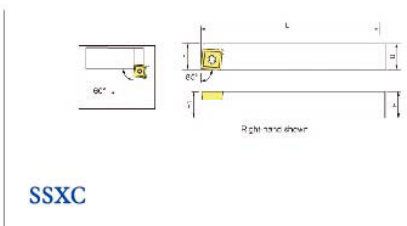

SSXC

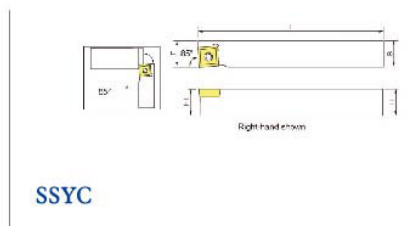

SSYC

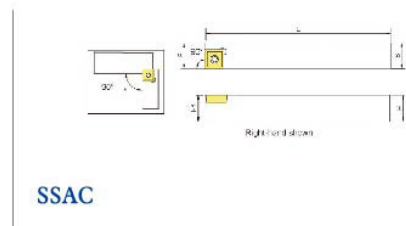

SSAC

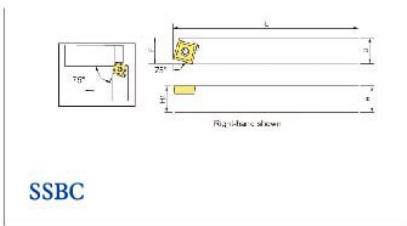

SSBC

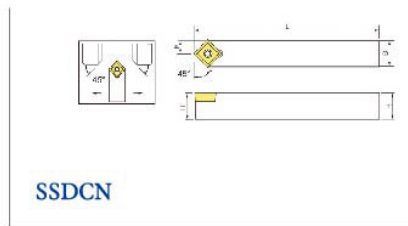

SSDCN

● 刀具系列 Cutting Tools Series

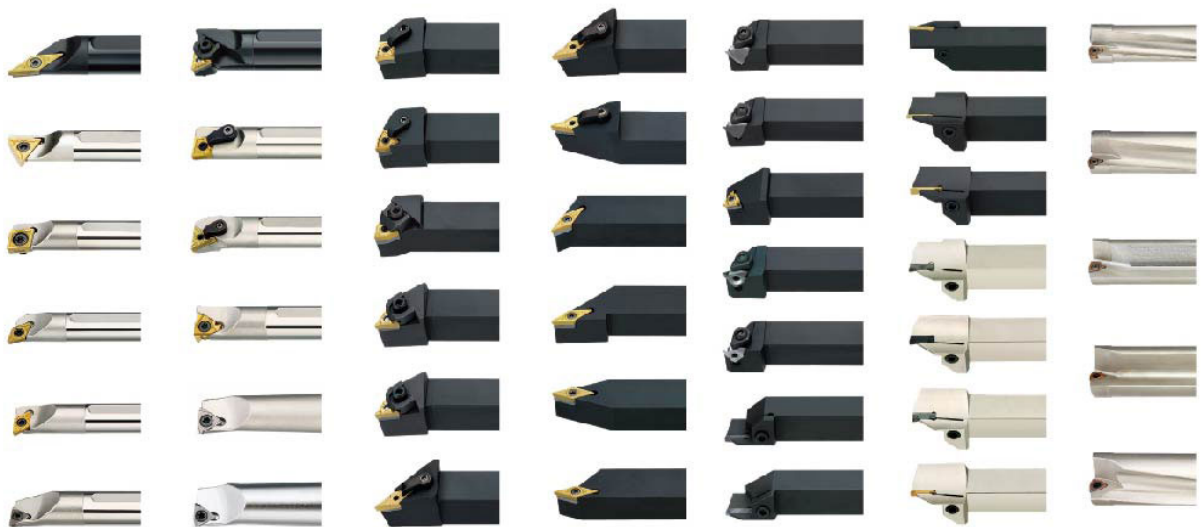



● 直角端銑刀  
Shoulder endmill



**MTR**

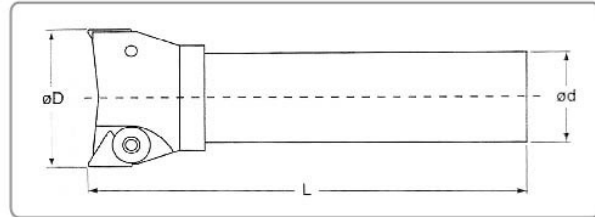

捨棄式銑刀系列

DISPOSABLE MILLING CUTTER SERIES

øD	ød	L	刃數	刀片型號	刀片螺絲	扳手
16	16	110	1	TPMN1103	SCR-W3/16	WRN-M3L
20	20	110	2			
25	20	110	2			
25	25	110	2			
30	20	130	2	TPMN1603	SCR-W1/4	WRN-M4L
30	25	130	2			
35	20	130	2			
35	25	130	2			
35	32	150	2			
40	20	130	3			
40	25	130	3			
40	32	150	3			
45	20	130	3			
45	25	130	3			
45	32	150	3			
50	20	130	3			
50	25	130	3			
50	32	150	3			
50	32	200	3			
63	32	150	4	TPMN2204	SCR-W5/16	WRN-M5L
50	32	150	3			
63	32	150	3			

● 快削型端銑刀  
High speed endmill



HEX

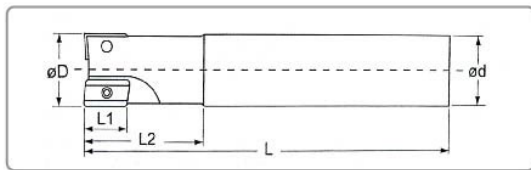

ØD	Ød	L1	L2	L	刃數
12	12	12	25	120	1
12	12	12	25	150	1
12	16	12	28	100	1
16	16	12	30	120	1
16	16	12	30	150	1
16	16	12	30	200	1
20	20	12	30	120	2
20	20	12	30	150	2
20	20	12	30	200	2
25	25	15	35	130	2
25	25	15	35	160	2
25	25	15	35	200	2
25	25	15	35	250	2
30	25	15	45	150	2
32	32	15	45	150	3
32	32	15	45	200	3

ØD 12~20 刀片型號 APET1202  
ØD 12~20 刀片螺絲 SCR-CEX3.5

ØD 25~32 刀片型號 APET1603  
ØD 25~32 刀片螺絲 SCR-CEX4

WRENCH 扳 手 T15

● 快削型端銑刀  
High speed endmill



MAP

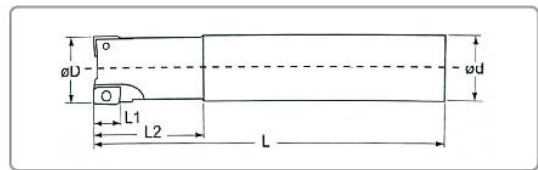

ØD	Ød	L1	L2	L	刃數
10	10	9	25	100	1
10	16	9	25	100	1
12	12	9	25	100	1
12	16	9	25	100	1
13	12	9	25	100	1
16	16	9	25	120	2
16	16	9	25	160	2
17	16	9	25	160	2
20	20	9	30	120	2
20	20	9	30	150	2
20	20	9	30	200	2
21	20	9	30	200	2
25	25	9	35	150	4
25	25	9	35	200	4
25	25	9	35	250	4

ØD 10~35 刀片型號 APMT  
1135PDER

ØD 10~35 刀片螺絲 SCR-CEX2.5

WRENCH 扳 手 T8



● **快削型端銑刀**  
High speed endmill

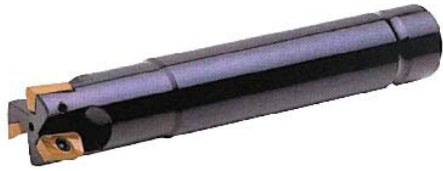

**MAP400R**

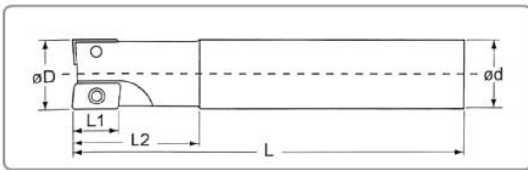

ØD	Ød	L1	L2	L	刃數
25	25	14	35	150	2
25	25	14	35	200	2
25	25	14	35	250	2
30	25	14	45	150	2
30	25	14	45	200	2
30	25	14	45	250	2
32	32	14	45	150	3
32	32	14	60	200	3
32	32	14	60	250	3
32	32	14	60	300	3
35	32	14	45	150	3
35	32	14	45	200	3
35	32	14	45	250	3
35	32	14	45	300	3
40	32	14	45	150	3
40	32	14	45	200	3
50	32	14	45	150	4
50	32	14	45	200	4
50	42	14	45	150	4

ØD 25~50 刀片型號

APMT  
1604DER

ØD 25~50 刀片螺絲

SCR-CAP4

WRENCH 扳 手

T15

● **R角端銑刀**  
Radius endmill



**MRP**

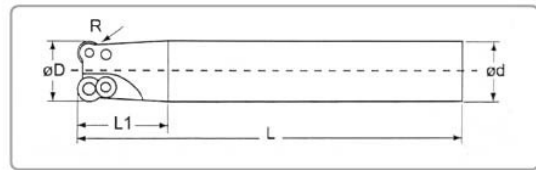

ØD	Ød	L1	L2	L	刃數
25	25	5	40	150	2
25	25	5	60	200	2
30	25	5	45	150	2
30	25	5	45	200	2
30	25	5	45	250	2
30	25	5	45	300	2
35	32	5	45	150	3
35	32	5	45	200	3
35	32	5	45	250	3
35	32	5	45	300	3
40	32	5	45	150	3
40	32	5	45	200	3
35	32	6	45	150	3
35	32	6	45	200	3
35	32	6	45	250	3
40	32	6	45	150	3
40	32	6	45	200	3

ØD 25~40 刀片型號

RPMW-1003MO

ØD 25~40 刀片螺絲

SCR-CRP4, SCR-W3/16S

ØD 35~40 刀片型號

RPMW-1203MO

ØD 35~40 刀片螺絲

SCR-CRP4L, SCR-W3/16S

WRENCH 扳 手

T15

捨棄式銑刀系列  
DISPOSABLE MILLING CUTTER SERIES

● 快削型平面銑刀 Face milling cutter



MAP400R

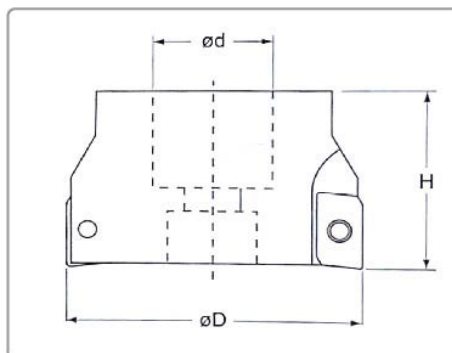

ØD	Ød	d*	H	刀數	刀片型號	刀片螺絲	扳 手
50	25.4	22	40	4	APMT1604	SCR-CAP4	T15
63	25.4	22	40	5			
80	25.4	27	50	6			
100	31.75	32	50	7			
125	38.1	40	50	8			
160	38.1	40	50	10			

● 直角平面銑刀 Face milling cutter

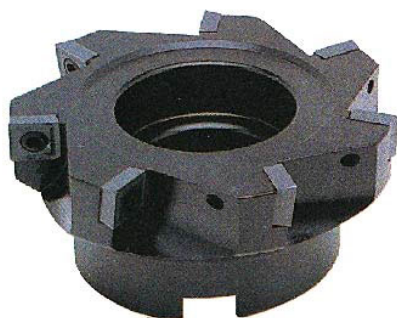

MSF

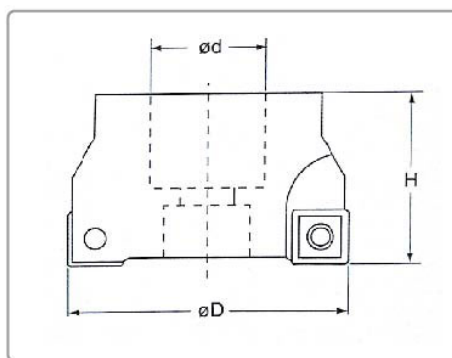

ØD	Ød	d*	H	刀數	刀片型號	刀片螺絲	扳 手
50	-	22	40	4	SPLT1204	SCR-SFM5	T20
63	25.4	27	40	5			
80	25.4	27	45	6			
100	31.75	32	50	7			

● **CRS型R角平面銑刀** Face milling cutter

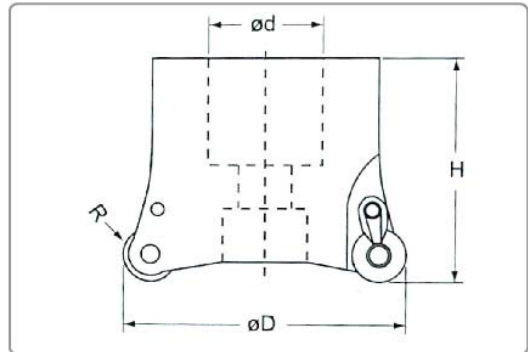

**MRS**

ØD	Ød	d*	R	H	刀數	刀片型號	刀片螺絲	壓板	壓板螺絲	扳手	
50	25.4	22	5	45	4	APMT1604	SCR-CAP4	CL-5R	SCR-CRS3.5	T15	
63	25.4	22	5	50	5	RDMT 1204MOTN	SCR-CRS4L	CL-6R			
50	-	22	6	45	4		APMT 1604	SCR- CRS5			CL-8R
60	25.4	22	6	50	5	-					SCR- W1/4S
50	-	22	8	45	3	CL-8R116H	SCR-CRS6	SCR-CRS5			
60	25.4	22	8	50	3/4						
66	25.4	27	8	50	4						
80	25.4	27	8	50	5						
100	31.75	32	8	55	5						
116	31.75	32	8	60	6						

● **CRP 型R角平面銑刀** Face milling cutter

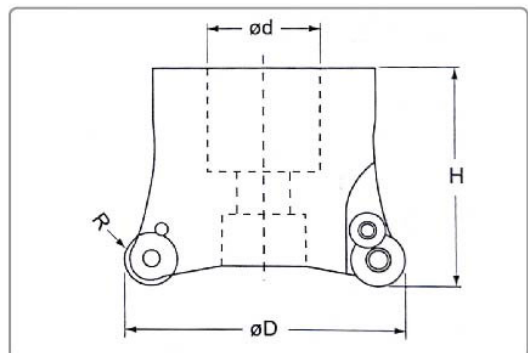

**MRP**

ØD	Ød	d*	H	刀數	刀片型號	刀片螺絲	扳手
50	-	22	45	4	RPMW1003MO	SCR-CRP4	T15
63	25.4	22	50	5		SCR-W3/16S	
50	-	22	45	4	RPMW1203MO	SCR-CRS4L	
63	25.4	22	50	5		SCR-W3/16S	

● 球形精銑刀 Ball-Nose endmill



M2139

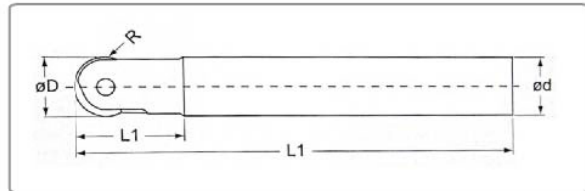

ØD	Ød	R	L1	L	刀片型號	刀片螺絲	扳 手
8	8	4	30	130	P3200D08	SCR-CR4i	T8
10	10	5	30	130	P3200D10	SCR-CR5i	T15
10	12	5	30	130			
12	12	6	32	130	P3200D12	SCR-CR6i	
16	16	8	36	150	P3200D16	SCR-CR8i	T20
20	20	10	45	160	P3200D20	SCR-CR10i	
20	20	10	45	200			
25	25	12.5	45	180	P3200D25	SCR-CR12.5i	T30

● 球形精銑刀 Ball-Nose endmill

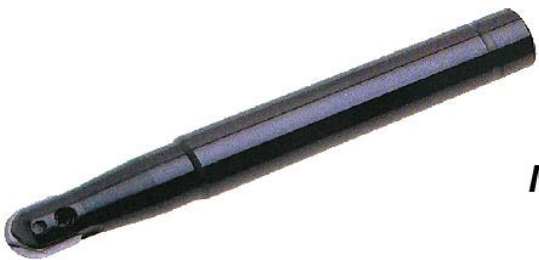

MBP

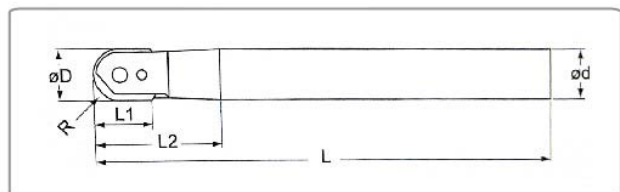

ØD	Ød	R	L1	L2	L	刀片型號	刀片螺絲-前	刀片螺絲-後	扳 手
16	16	8	13	40	160				
16	20	8	13	50	130				
16	20	8	13	65	160	ZPFW160	SCR-AR8	SCR-CBP3.5	T15
20	20	8	13	65	200				
25	25	8	13	65	200				
20	20	10	17	40	200	ZPFW200	SCR-AR10		
20	25	10	17	80	250			SCR-CBP5	T20
25	25	12.5	22	45	200	ZPFW250	SCR-AR12.5		



● 固定式雙刃粗搪刀 Twin-blade boring bar



**MTB**

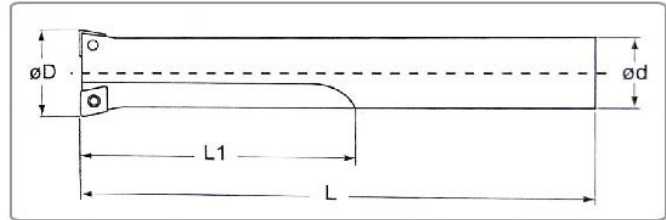

ØD	Ød	L1	L	刃數	刀片型號	刀片螺絲	扳 手
14.7	16	50	100	2	CCMT060204	SCR-TB2.5	T8
15.7	16	50	100	2			
16.7	16	50	100	2			
17.7	16	50	100	2			
19.7	16	60	110	2			
19.7	16	60	150	2			
21.7	16	60	110	2			
22.7	16	60	110	2			
23.7	20	70	120	2			
24.7	20	70	120	2			
29.7	25	90	160	2	CCMT09T308	SCR-TB3.5	T15
29.7	25	90	190	2			
34.7	25	90	160	2			
34.7	32	90	230	2			
39.7	25	90	160	2			
39.7	32	90	250	2			

捨棄式銑刀系列  
DISPOSABLE MILLING CUTTER SERIES

● 粗重切削筒型銑刀 Rotgh milling cutter



**RGM**

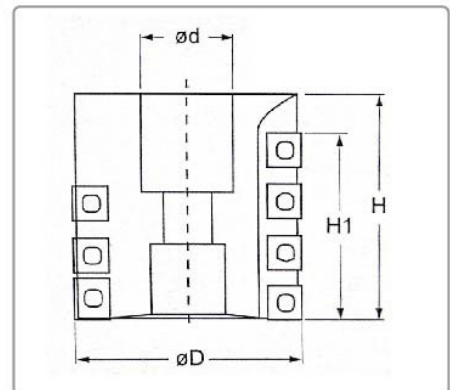

ØD	Ød	H1	H	槽數	端 刃	PCS	周 刃	PCS	刀片螺絲	扳 手
80	31.75	67	80	6	LPMT1504	3	SPMT1204	18	SCR-RGH5	T20
80	32	67	80							

71 ※ 本牌價依市場行情依於折扣優惠，歡迎查詢價格  
The discount will be offered based on current prices. Welcome to check the prices.

● 高進給切削端銑刀 High speed endmill

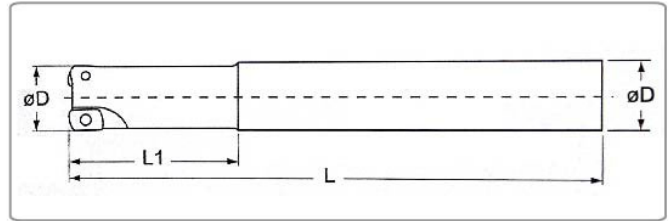

HSR06

ØD	Ød	L1	L	刃數	刀片型號	刀片螺絲	扳手
16	16	50	150	2	EPNW0603TN-8	SCR-ESR2.5	T7
20	20	50	150	3			
25	25	50	150	4			

● 45度倒角刀 Chamfering endmill

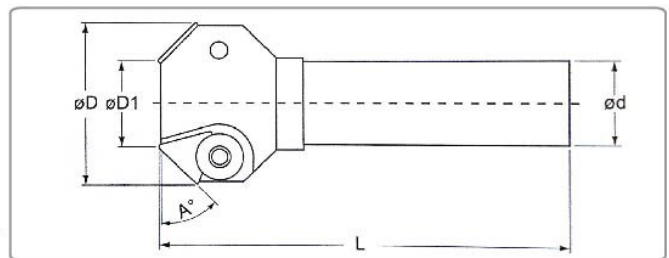

MV

ØD	ØD1	Ød	A°	L	刃數	刀片型號	刀片螺絲	扳手
5	21	16	45	120	1	TPUN1603	SCR-W1/4	WRN-M4L
5	21	20	45	120	1			
10	31	20	45	120	2			
20	50	25	45	130	3	TPUN2204	SCR-W5/16	WRN-M5L
20	50	32	45	130	3			
6	32	32	45	150	1			
35	63	25	45	150	3			
35	63	32	45	150	3			

● 螺絲頭沉孔銑刀 Bolt countersink endmill



**MH**

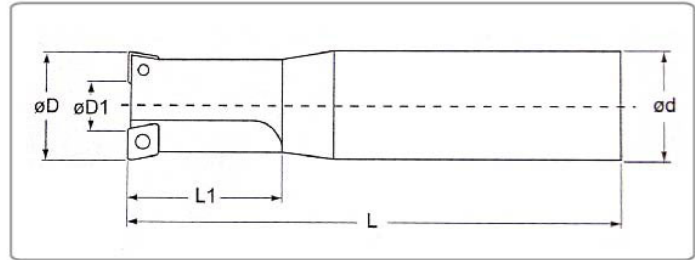

ØD	ØD1	Ød	L1	L	刃數	刀片型號	刀片螺絲	扳 手
14	2.9	25	21	21	1	CCMT060204	SCR-CH2.5	T8
175	5.3	25	26	26	2			
20	7.8	25	30	39	2			
23	10.8	25	34.5	34.5	2	CPMT090308	SCR-CH3.5	T15
26	8.5	32	39	39	2			
29	11.5	32	43.5	43.5	2			
32	14.5	32	59	59	2			

● T型槽端銑刀 T-slot Endmill

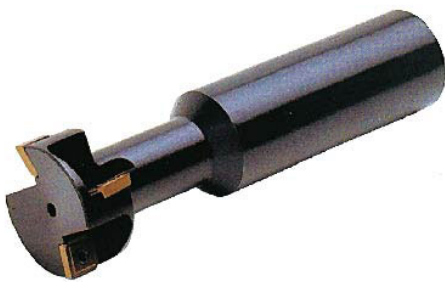

**TH**

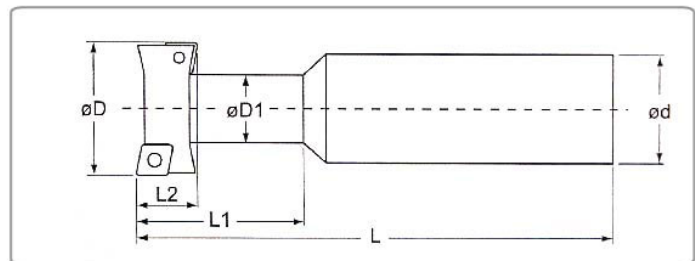

ØD	ØD1	Ød	L1	L2	L	刃數	刀片型號	刀片螺絲	扳 手
24	20	12	11	29	90	4	CCMT060204	SCR-TS2.5	T8
31	25	15	14	42	110	4	CCMT080204Z		
39	32	20	18	49	120	4	CPMT090308	SCR-TS4	T15
49	32	25	22	60	140	4	CPMT120408	SCR-TS5	T15

● 45度高速平面殼型銑刀 milling cutter

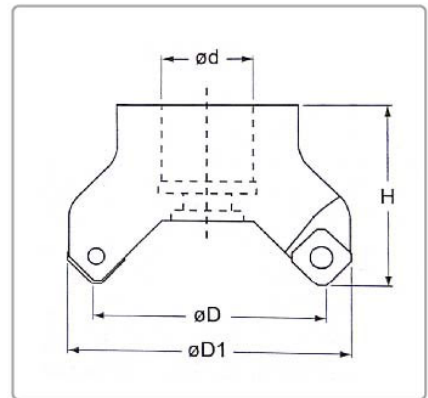

HS

$\phi D$	$\phi D1$	$\phi d$	$d^*$	H	刃數	刀片型號	刀片螺絲	扳手
50	60	-	22	45	4	SEKT1204	SCR-SE5	T20
63	75	25.4	27	50	5			
80	96	25.4	27	55	6			
100	116	31.75	32	55	6			
125	141	38.1	40	60	8			
150	158	50.8	40	60	10			
200	212	47.625	60	60	12			
250	268	47.625	-	60	12			

● 45度高速殼型銑刀 milling cutter

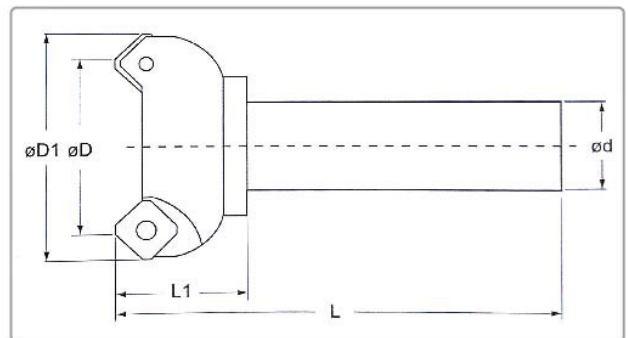

HS

$\phi D$	$\phi D1$	$\phi d$	L1	L	刃數	刀片型號	刀片螺絲	扳手
50	62	32	45	150	4	SEKT1204	SCR-SE5	T20
50	62	25	45	120	4			
63	74	32	45	150	5			
63	74	25	45	120	5			

● 直角平面銑刀 Shoulder face milling cutter

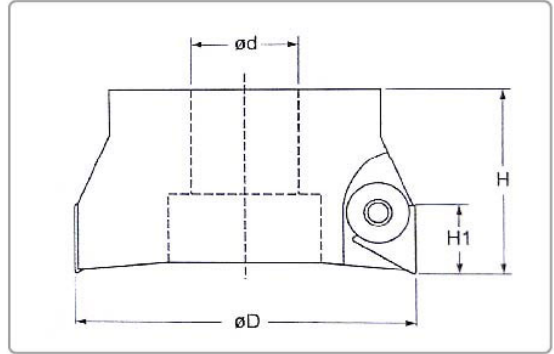

TPR

$\phi D$	$\phi D1$	$d^*$	H1	H	刃數	刀片型號	刀片螺絲	墊片	墊片螺絲	扳 手
63	25.4	27	22	50	3	TPMN2204	SCR-W5/16	ST-T	SCR-ST-T4	WRN-M5T
80	25.4	27	22	50	4					
100	31.75	32	22	55	5					
125	38.1	40	22	60	6					
160	50.8	40	22	60	7					
200	47.625	60	22	60	8					
250	47.625	60	22	60	9					
300	47.625	60	22	60	10					

捨棄式銑刀系列  
DISPOSABLE MILLING CUTTER SERIES

● 千鳥型側銑刀 Sidemilling cutter

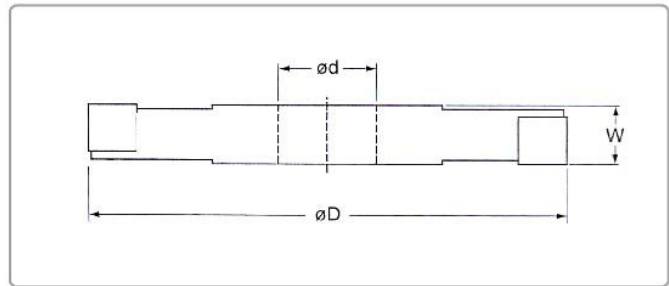

SC

$\phi D$	$\phi d$	W	刃數	刀片型號	壓板	壓板螺絲	扳 手
100	25.4	16	10	SPUN1203	CL-S CL-SL	SCR-CL5/16	WRN-M4T
125	25.4	16	14				
125	25.4	20	14				
150	31.75	16	16				
150	31.75	20	16				
200	31.75	16	20				
200	31.75	20	20				

75 ※ 本牌價依市場行情依於折扣優惠，歡迎查詢價格  
The discount will be offered based on current prices. Welcome to check the prices.

● T型側銑刀 T type sidemilling cutter

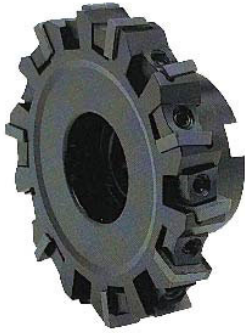

SCT

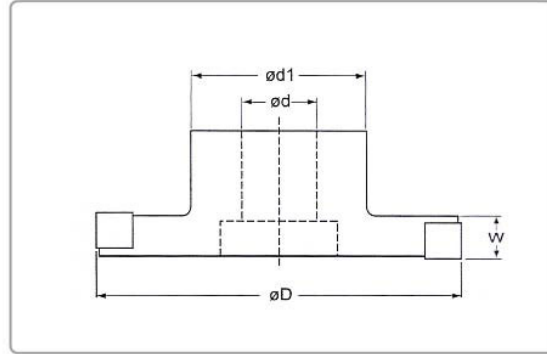

ØD	Ød	d1	W	刃數	刀片型號	壓板	壓板螺絲	扳手
100	25.4	30	16	10	SPUN-1203	CL-S CL-SL	SCR- CL5/16	WRN-M4T
125	31.75	70	16	14				
125	31.75	70	20	14	SPUN-1504			
150	31.75	70	16	16	SPUN-1203			
150	31.75	70	20	16	SPUN-1504			
200	31.75	70	20	20				
200	31.75	70	25	20				

● 75度平面銑刀 75°milling cutter



FP

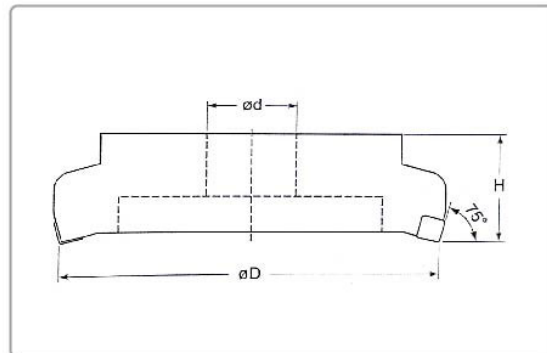

ØD	Ød	d*	H	刃數	刀片型號	壓板	壓板螺絲	墊片	墊片螺絲	扳手
80	25.4	27	50	5	SPUN-1203 SPKN-1203	CL-S	SCR- CL5/16	ST-S	SCR- ST/S4	WRN-M4T
100	31.75	32	55	6						
125	38.1	40	60	8						
160	50.8	40	60	10						
200	47.625	60	60	12						
250	47.625	60	60	16						
300	47.625	60	60	20						



● 65度平面銑刀 65°face milling cutter

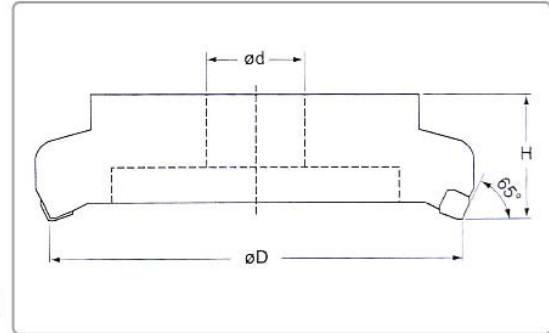
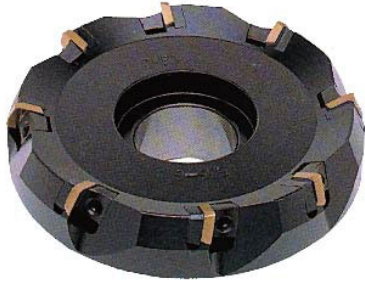

**535**

ØD	Ød	d*	H	刀數	刀片型號	壓板	壓板螺絲	墊片	墊片螺絲	扳手
80	25.4	27	50	5	SPKN-1504	CL5-S	SCR-CL5/16	ST-S	SCR-ST/S4	WRN-M4T
100	31.75	32	55	5						
125	38.1	40	60	6						
160	50.8	40	60	8						
200	47.625	60	60	10						
250	47.625	60	60	12						
300	47.625	60	60	14						

● 65度平面銑刀 65° face milling cutter

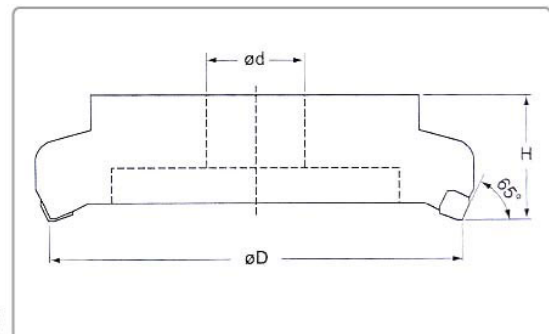

**435**

ØD	Ød	d*	H	刀數	刀片型號	壓板	壓板螺絲	墊片	墊片螺絲	扳手
80	25.4	27	50	5	SPKN-1204	CL4-S	SCR-CL5/16	ST-S	SCR-ST/S4	WRN-M4T
100	31.75	32	55	5						
125	38.1	40	60	6						
160	50.8	40	60	8						
200	47.625	60	60	10						
250	47.625	60	60	12						
300	47.625	60	60	14						

77 ※本牌價依市場行情依於折扣優惠，歡迎查詢價格  
The discount will be offered based on current prices. Welcome to check the prices.

● 45度平面銑刀 45° face milling cutter

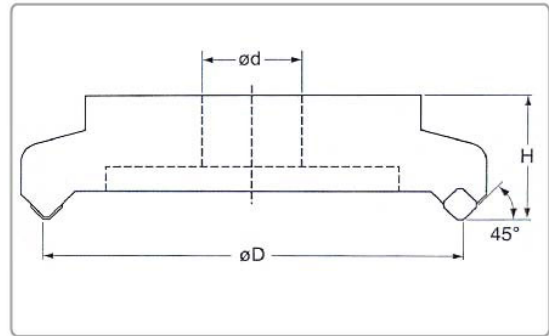

45

ØD	Ød	d*	H	刃數	刀片型號	壓板	壓板螺絲	墊片	墊片螺絲	扳手
80	25.4	27	50	5	SPKN-1504	CL5-S	SCR-CL5/16	ST-S	SCR-ST/S4	WRN-M4T
100	31.75	32	55	5						
125	38.1	40	60	6						
160	50.8	40	60	8						
200	47.625	60	60	10						
250	47.625	60	60	12						
300	47.625	60	60	14						

● 45度平面銑刀 45° face milling cutter

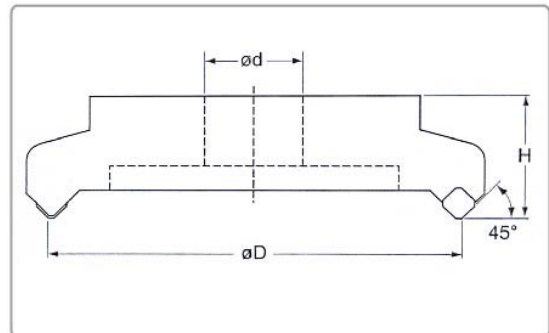

45

ØD	Ød	d*	H	刃數	刀片型號	壓板	壓板螺絲	墊片	墊片螺絲	扳手
80	25.4	27	50	5	SPKN-1203	CL4-S	SCR-CL5/16	ST-S	SCR-ST/S4	WRN-M4T
100	31.75	32	55	5						
125	38.1	40	60	6						
160	50.8	40	60	8						
200	47.625	60	60	10						
250	47.625	60	60	12						
300	47.625	60	60	14						



● 一體式圓刀刃銑刀 X-POWER Radius milling cutter

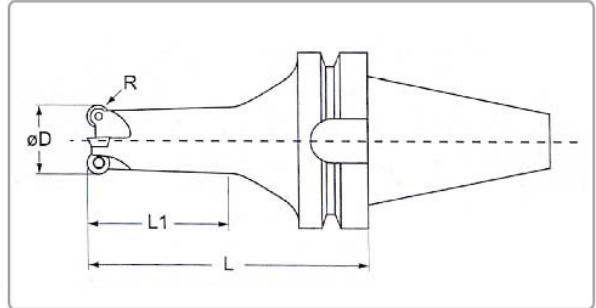

**MQP**

ØD	R	L1	L	刀數	刀片型號	刀片螺絲	扳手
20	4	40	90	3	QPMT0803	SCR-QP3	T8
25	4	50	100	4			
25	4	80	130	4			
25	5	50	100	3	QPMT10T3	SCR-QP3.5	T15
32	5	50	100	4			
32	5	80	130	4			

捨棄式銑刀系列  
DISPOSABLE MILLING CUTTER SERIES

● 一體式圓刀刃銑刀 Shoulder face milling cutter

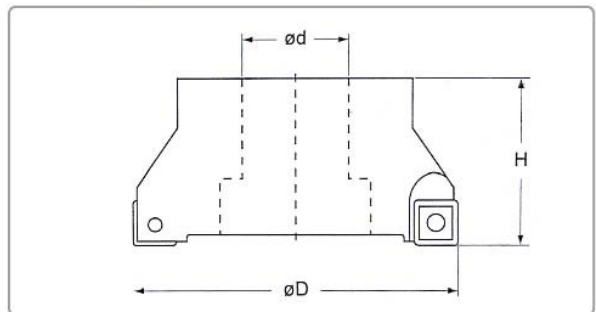

**M280S**

ØD	Ød	d*	H	刀數	刀片型號	刀片螺絲	扳手	墊片	墊片螺絲	扳手
50	-	22	40	3	R290.90-12T3 OR SOMT 12T3	SCR-C290S	T15	ST-C290	SCR-ST	WRN-M5
50	-	22	40	4						
63	25.4	22	40	4						
63	25.4	22	40	5						
80	25.4	27	50	4						
80	25.4	27	50	6						
100	31.75	32	50	5						
100	31.75	32	50	7						
125	38.1	40	64	6						
125	38.1	40	64	8						
160	50.8	40	64	8						
200	47.625	60	64	10						

● 替換式銑刀 Radius corner modular endmill



RD

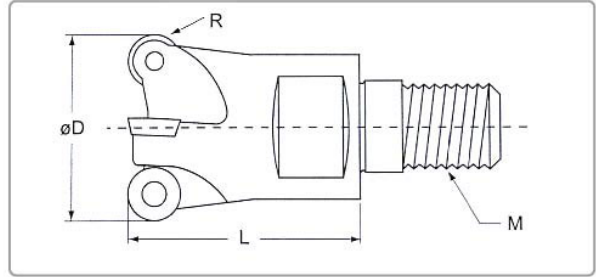

ØD	R	M	L	刃數	刀片型號	刀片螺絲	壓板	壓板螺絲	扳手
10	2.5	M5	18	2	RDHW 0501	SCR- RD2.0	-	-	T6
11	2.5	M5	18	2					
12	2.5	M6	19	3					
13	2.5	M6	19	3	RDHW 0702	SCR- RD2.5	-	-	T8
16	3.5	M8	23	3					
17	3.5	M8	23	3					
20	3.5	M10	30	3					
21	3.5	M10	30	3					
25	3.5	M12	35	4					
25	3.5	M12	35	5	RDHW 1003	SCR- RD3.5	CL-RD100	SCR-RD3.5	T15
26	3.5	M12	35	4					
35	3.5	M16	43	5					
35	5	M16	43	3					
35	5	M16	43	4					

● 快削型平面銑刀 High-speed rough endmill



APM18

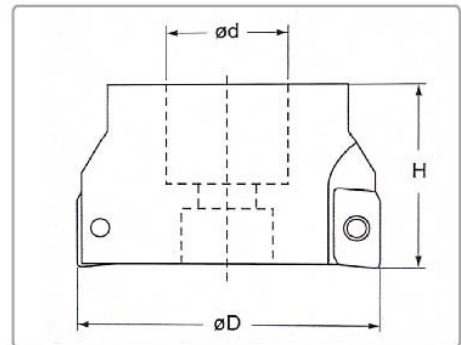

ØD	Ød	d*	H	刃數	刀片型號	刀片螺絲	扳手
50	-	22	40	5	AOMT1848	SCR-APX4	T15
63	25.4	22	40	6			
80	25.4	27	50	7			
100	31.75	32	50	8			
125	38.1	40	50	9			



● 快速型端銑刀 High speed rough endmill

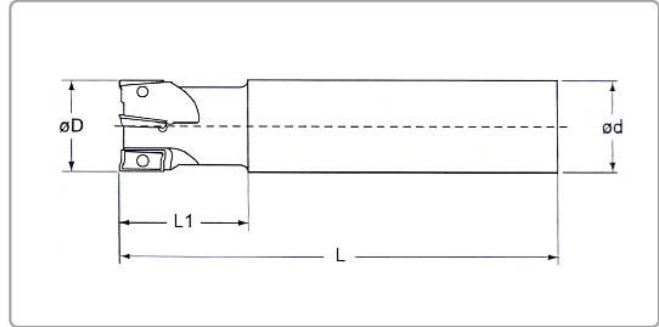
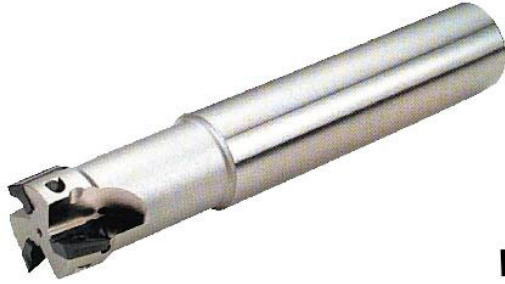

**WEX**

捨棄式銑刀系列  
DISPOSABLE MILLING CUTTER SERIES

ØD	d	L1	L	刀數	刀片型號	刀片螺絲	扳 手
16	16	25	100	2	AXMT1235	SCR-WEX3	T8
18	16	25	100	2			
20	20	30	110	3			
20	20	40	150	3			
22	22	30	110	3			
25	25	35	120	4			
25	25	50	170	4			
28	28	35	120	4			
32	32	40	130	5			
32	32	60	180	5			
25	25	35	120	2	AXMT1705	SCR-WEX4	T15
26	26	35	120	2			
28	28	35	120	2			
32	32	40	130	3			
32	32	60	180	3			
35	35	40	130	3			
40	40	50	170	4			

● RD型R角端銑刀 Corner radius endmill



RD

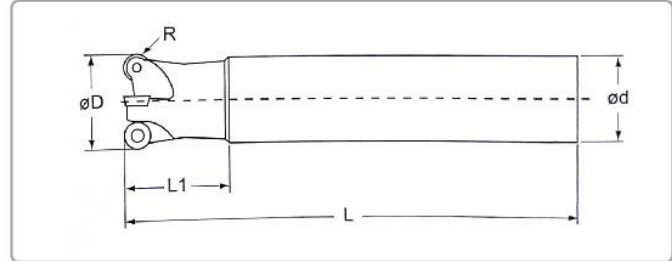

ØD	ød	R	L1	L	刀數	刀片型號	刀片螺絲	壓板	壓板螺絲	扳手
12	12	2.5	30	100	3	RDWH 0501	SCR- RD2.0	—	—	T6
13	12	2.5	30	100	3					
16	16	3.5	30	150	3					
17	16	3.5	30	150	3	RDWH 0702	SCR- RD2.5	—	—	T8
17	16	3.5	30	200	3					
20	20	3.5	30	150	3					
21	20	3.5	30	150	3					
21	20	3.5	30	200	3					
25	25	3.5	30	150	4	RDWH 1003	SCR- RD3.5	CL-RD10	SCR- RD3.5	T15
26	25	3.5	30	150	4					
26	25	3.5	30	200	4					
35	32	5	50	150	3					
35	32	5	50	200	3					
35	32	5	50	250	3					
35	32	5	50	300	3					
35	32	5	50	150	4					
35	32	5	50	200	4					

● 捨棄快速沈頭用柱孔刀

材料：SKD61 抗震度佳

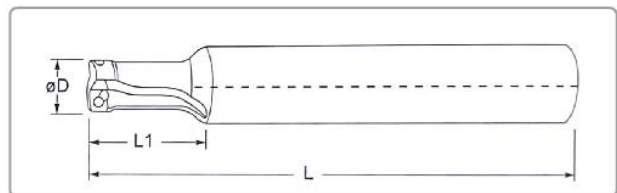

刀數	ØD	刀長L1	全長L
1	9.5	16	120
1	11	12	125
1	14.7	16	160
2	14	20	160
2	15	20	160

特性：進給快、轉速快、孔面佳

捨棄式銑刀具系列  
DISPOSABLE MILLING CUTTER SERIES

● 快速鑽2倍長 Super power drill 2D



**MXD-2D**

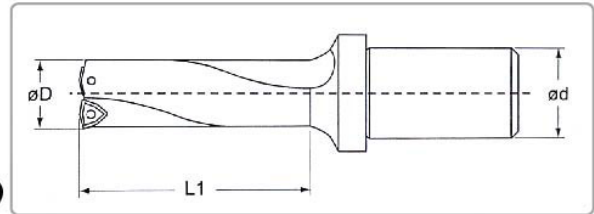

ØD	Ød	L1	刀數	刀片型號	刀片螺絲	扳 手
15	25	30	2	WCMX0302	SCR-EXD2.5	T8
16	25	32	2			
17	25	34	2			
18	25	36	2			
19	25	38	2			
20	25	40	2	WCMX0402	SCR-EXD2.5	T8
21	32	42	2			
22	32	44	2			
23	32	46	2			
24	32	48	2			
25	32	50	2	WCMX0503	SCR-EXD3	T8
26	32	52	2			
27	32	54	2			
28	32	56	2			
29	32	58	2			
30	32	60	2	WCMX06T3	SCR-EXD3.5	T15
31	32	62	2			
32	32	64	2			
33	32	66	2			
34	32	68	2			
35	32	70	2			

捨棄式銑刀系列  
DISPOSABLE MILLING CUTTER SERIES

● 多功能捨棄內外倒角刀

材料：SKD61 抗震度佳



**MSH**

特性：雙角度刀片，增加進給捨棄式刀片設計，耐用度高、使用壽命長

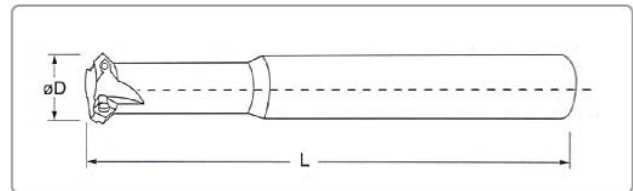

刀數	ØD	全長L
2	15	90° x 100L
3	20	90° x 120L
4	24	90° x 150L

● 快速鑽3倍長 Super power drill 3D



MXD-3D

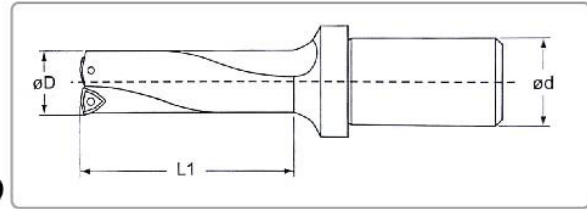

ØD	Ød	L1	刃數	刀片型號	刀片螺絲	扳 手
14	25	42	2	WCMX0302	SCR-EXD2.5	T8
15	25	45	2			
16	25	48	2			
17	25	51	2			
18	25	54	2			
19	25	57	2			
20	25	60	2	WCMX0402	T8	
21	32	63	2			
22	32	66	2			
23	32	69	2			
24	32	72	2			
25	32	75	2			
26	32	78	2	WCMX0503	T8	
27	32	81	2			
28	32	84	2			
29	32	87	2			
30	32	90	2			
31	32	93	2			
32	32	96	2	WCMX06T3	T15	
33	32	99	2			
34	32	102	2			
35	32	105	2			
36	32	108	2			
37	32	111	2			
38	32	114	2			
39	32	117	2			
40	32	120	2			
41	40	123	2			
42	40	126	2			
43	40	129	2			WCMX0804
44	40	132	2			
45	40	135	2			
46	40	138	2			
47	40	141	2			
48	40	144	2			
49	40	147	2			
50	40	150	2			
51	40	153	2			
52	40	156	2			
53	40	159	2			
54	40	162	2	WCMX06T3	T15	
55	40	165	2			
56	40	168	2			
57	40	171	2			
58	40	174	2			
59	40	177	2			
60	40	180	2			



● 快速鑽4倍長 Super power drill 4D



**MXD-4D**

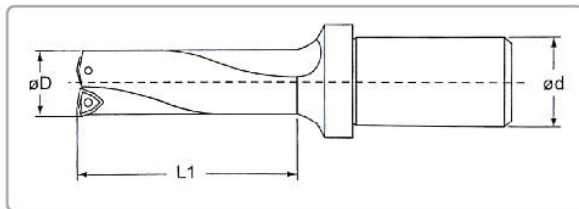

ØD	Ød	L1	刀數	刀片型號	刀片螺絲	扳 手
15	25	60	2	WCMX0302	SCR-EXD2.5	T8
16	25	64	2			
17	25	68	2			
18	25	72	2			
19	25	76	2			
20	25	80	2			
21	32	84	2	WCMX0402	T8	
22	32	88	2			
23	32	92	2			
24	32	96	2			
25	32	100	2			
26	32	104	2			
27	32	108	2	WCMX0503	T8	
28	32	112	2			
29	32	116	2			
30	32	120	2			
31	32	124	2			
32	32	128	2			
33	32	132	2	WCMX06T3	T15	
34	32	136	2			
35	32	140	2			
36	32	144	2			
37	32	148	2			
38	32	152	2			
39	32	156	2			
40	32	160	2			
41	40	164	2			
42	40	168	2			
43	40	172	2			
44	40	176	2			
45	40	180	2	WCMX0804	T15	
46	40	184	2			
47	40	188	2			
48	40	192	2			
49	40	196	2			
50	40	200	2			
51	40	204	2	WCMX06T3	T15	
52	40	208	2			
53	40	212	2			
54	40	216	2			
55	40	220	2			
56	40	224	2			
57	40	228	2			
58	40	232	2			
59	40	236	2			
60	40	240	2			

捨棄式銑刀系列  
DISPOSABLE MILLING CUTTER SERIES

● 快速型端銑刀 high speed rough endmill



AXO

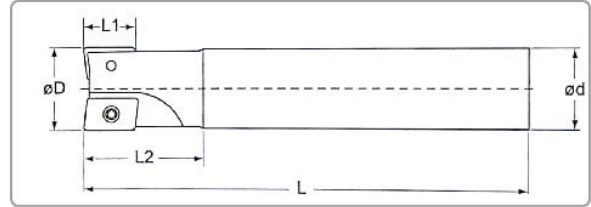

ØD	Ød	L1	L2	L	刃數	刀片型號	刀片螺絲	扳 手
10	10	5	28	100	2	XOMX-0602	SCR-AXO1.8	T6
11	10	5	28	100	2			
12	12	5	28	120	2			
13	12	5	33	120	2			
14	12	5	25	120	3			
20	20	11	26	85	2	XOMX-1204	SCR-AXO3.5	T10
20	20	11	26	150	2			
20	20	11	26	200	2			
22	20	11	26	150	2			
25	25	11	32	90	3			
25	25	11	32	150	3			
25	25	11	32	200	3			

● 快速型平面銑刀 high speed rough face endmill cutter



WEX

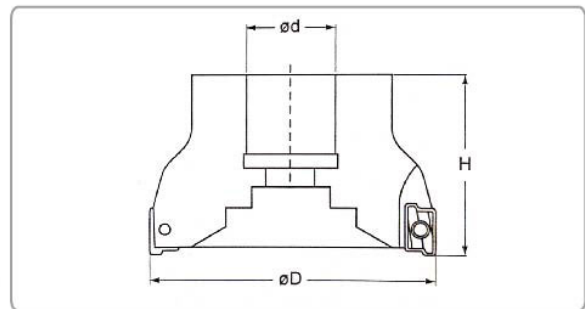

ØD	Ød	d*	H	刃數	刀片型號	刀片螺絲	扳 手
50	-	22	40	7	AXMT1235	SCR-WEX3	T8
63	25.4	22	40	8			
50	-	22	40	5	AXMT1705	SCR-WEX4	T15
63	25.4	22	40	6			
80	25.4	27	50	7			
100	31.75	32	63	8			
125	38.1	40	63	9			

## ● SDC 後拉式精密刀把

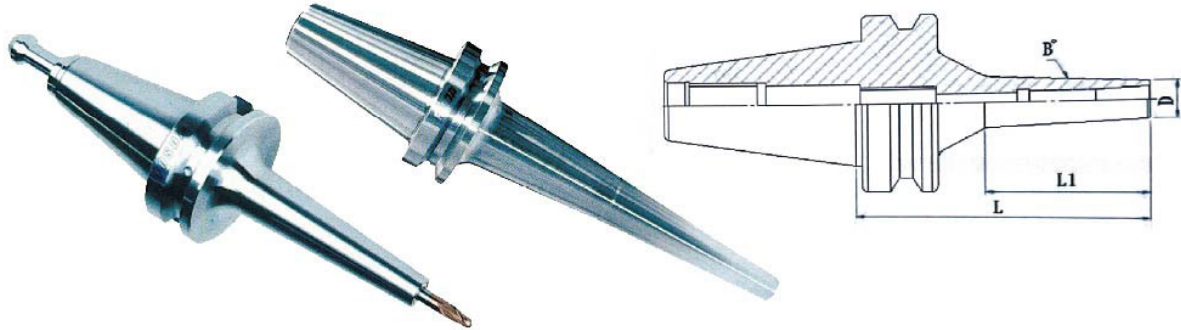

品 號	FIG	夾持範圍	ØD	ØD1	Ød1	L	θ	WRENCH
BT30-SDC06-060K	1	Ø2-6	14	17	27.5	60		M4
BT30-SDC06-090K				20	30.5	90		
BT30-SDC12-080K	2	Ø3-12	34	-	34	80		M8
BT40-SDC06-060K	1	Ø2-6	14	16.3	23	60		M4
BT40-SDC06-090K				19.5	30	90		
BT40-SDC06-120K				24	34.5	120		
BT40-SDC06-150K				27.5	38	150		
BT40-SDC08-060K	1	Ø3-10	22	24.3	23	60		M5
BT40-SDC08-090K				27.5	38	90		
BT40-SDC08-120K				32	42.5	120		
BT40-SDC08-150K				35.5	46	150		
BT40-SDC12-070K	2	Ø3-12	34	-	34	70	2.86°	M8
BT40-SDC12-090K				-	37	90		
BT40-SDC12-120K				-	39	120		
BT40-SDC12-150K				-		150		
BT50-SDC06-110K	1	Ø2-6	14	21.5	32	110		M4
BT50-SDC06-155K				27	37.5	155		
BT50-SDC06-200K				30	40	200		
BT50-SDC08-110K	1	Ø3-10	22	29.5	40	110		M5
BT50-SDC08-155K				35	45.5	155		
BT50-SDC08-200K				38	48	200		
BT50-SDC12-110K	2	Ø3-12	34	-	37	110		M8
BT50-SDC12-155K				-	39	155		
BT50-SDC12-200K				-	41	200		

● SDC 後拉式刀把



品 號	D	L	Ød
SDC6	9.5	36	2 2.5 3 3.175 3.5 4 4.5 5 5.5 6
SDC8	15	45	3 3.175 4 5 6 7 8 9 10
SDC12	22	60	3 3.175 4 5 6 7 8 9 10 12



● **SK 高精度刀把**

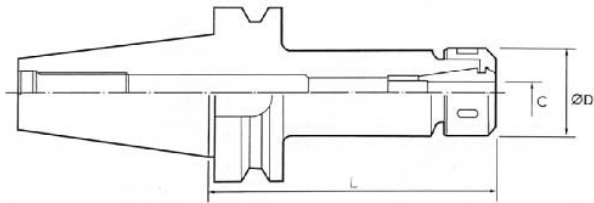

機械刀桿系列

MECHANICAL KNIFE BAR SERIES

品 號	ØD	L	C
BT30-SK06-70	20	70	2~6
BT30-SK06-100	20	100	2~6
BT30-SK10-70	35	70	2~10.3
BT30-SK10-100	35	100	2~10.3
BT30-SK13-60	35	60	3~12
BT30-SK13-90	35	90	3~12
BT30-SK16-70	46	70	4~16
BT30-SK16-100	46	100	4~16
BT30-SK25-100	58	100	12~25
BT40-SK06-70	20	70	2~6
BT40-SK06-100	20	100	2~6
BT40-SK10-70	35	70	2~10.3
BT40-SK10-100	35	100	2~10.3
BT40-SK10(S)-100	30	100	2~10.3
BT40-SK10-125	35	125	2~10.3
BT40-SK10-150	35	150	2~10.3
BT40-SK16-70	46	70	4~16
BT40-SK16-80	46	80	4~16
BT40-SK16-100	46	100	4~16
BT40-SK16-125	46	125	4~16
BT40-SK16-150	46	150	4~16
BT40-SK25-80	58	80	12~25
BT40-SK25-100	58	100	12~25
BT40-SK25-125	58	125	12~25
BT40-SK25-150	58	150	12~25
BT50-SK10-100	35	100	2~10.3
BT50-SK10-125	35	125	2~10.3
BT50-SK10-150	35	150	2~10.3
BT50-SK10-200	35	200	2~10.3
BT50-SK10(S)-150	30	150	2~10.3
BT50-SK10(S)-200	30	200	2~10.3
BT50-SK16-100	46	100	4~16

品 號	ØD	L	C
BT50-SK16-125	46	125	4~16
BT50-SK16-150	46	150	4~16
BT50-SK25-100	58	100	12~25
BT50-SK25-125	58	125	12~25
BT50-SK25-150	58	150	12~25

● SK 筒夾

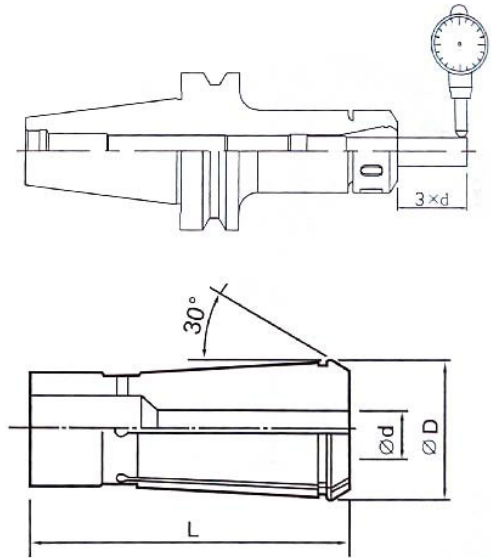
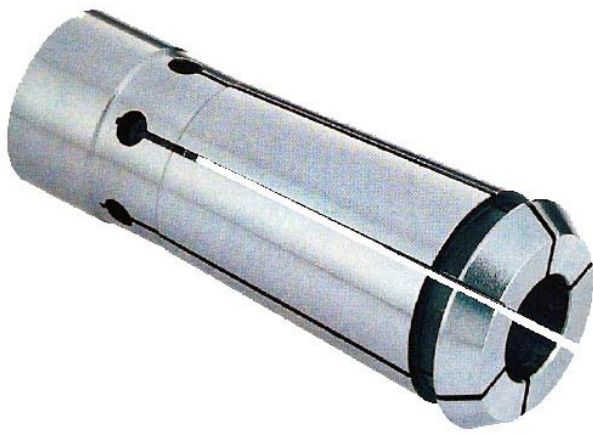

品 號	規格	D	L	COLLET
SK6	06	12.1	40.6	3.4.6
SK6	06-D	12.1	40.6	2.5/3.2/3.3/3.5/4.2/4.5/5.0/5.5
SK10	10	17.3	46.5	3.4.6.8.10
SK10	10-D	17.3	46.5	2/2.5/3.2/3.3/4.2/5.5/6.2/6.8/8.5/10.3
SK16	16	26.4	60	4.6.8.10.12.16
SK16	16	26.4	60	5.9.10.3.12.5
SK25	25	33.3	70	10.12.16
SK25	25	33.3	70	11.13.14.15.17.18.19.21.22.23.24



● ER 銑刀夾頭

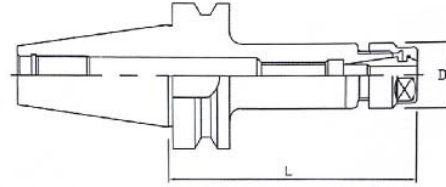
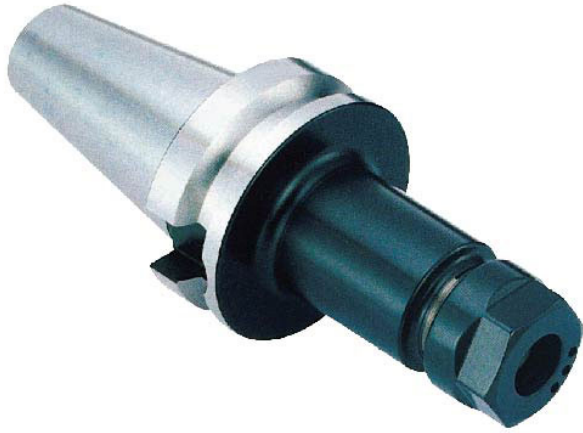

FIG.1

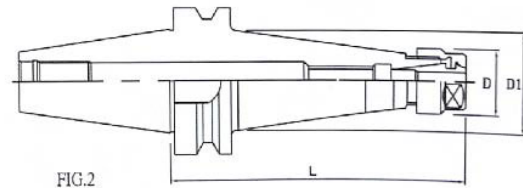

FIG.2

品 號	Fig	夾持能力	L	D	D1	COLLET TYPE
BT30-ER11-60	1	0.5-7	60	19		ER-11
BT30-ER11-60-M	1	0.5-7	60	16		ER-11
BT30-ER11-80	1	0.5-7	80	19		ER-11
BT30-ER11-80-M	1	0.5-7	80	16	22	ER-11
BT30-ER11-100	2	0.5-7	100	19	19	ER-11
BT30-ER11-100-M	2	0.5-7	100	16		ER-11
BT30-ER16-60	1	0.5-10	60	28		ER-16
BT30-ER16-70	1	0.5-10	70	28		ER-16
BT30-ER16-70-M	1	0.5-10	70	23		ER-16
BT30-ER16-80	1	0.5-10	80	28		ER-16
BT30-ER16-100	1	0.5-10	100	28		ER-16
BT30-ER16-100-M	2	0.5-10	100	23	25	ER-16
BT30-ER20-60	1	0.5-10	60	34		ER-20
BT30-ER20-70	1	1-13	70	34		ER-20
BT30-ER20-70-M	1	1-13	70	28		ER-20
BT30-ER20-80	1	1-13	80	34		ER-20
BT30-ER20-100	1	1-13	100	34		ER-20
BT30-ER20-100-M	2	1-13	100	28		ER-20
BT30-ER20-135	2	1-13	135	34	32	ER-20
BT30-ER25-60	1	1-16	60	42	40	ER-25
BT30-ER25-70	1	1-16	70	42		ER-25
BT30-ER25-80	1	1-16	80	42		ER-25
BT30-ER25-100	1	1-16	100	42		ER-25
BT30-ER32-60	1	2-20	60	50		ER-32
BT30-ER32-80	1	2-20	80	50		ER-32
BT30-ER32-100	1	2-20	100	50		ER-32
BT30-ER40-70	1	2-26	70	63		ER-40
BT30-ER11-70	1	0.5-7	70	19		ER-11
BT30-ER11-70-M	1	0.5-7	70	16		ER-11
BT30-ER11-100	2	0.5-7	100	19	22	ER-11

91 ※ 本牌價依市場行情依於折扣優惠，歡迎查詢價格  
The discount will be offered based on current prices. Welcome to check the prices.

品 號	Fig	夾持能力	L	D	D1	COLLET TYPE
BT40-ER11-100-M	2	0.5-7	100	16	20	ER-11
BT40-ER16-70	1	0.5-10	70	28		ER-16
BT40-ER16-100	1	0.5-10	100	28		ER-16
BT40-ER16-100-M	2	0.5-10	100	23	25	ER-16
BT40-ER16-125	1	0.5-10	125	28		ER-16
BT40-ER16-125-M	2	0.5-10	125	23	25	ER-16
BT40-ER16-150	2	0.5-10	150	28	32	ER-16
BT40-ER16-150-M	2	0.5-10	150	23	28	ER-16
BT40-ER16-200	2	0.5-10	200	28	34	ER-16
BT40-ER20-70	1	1-13	70	34		ER-20
BT40-ER20-100	1	1-13	100	34		ER-20
BT40-ER20-100-M	1	1-13	100	28		ER-20
BT40-ER20-125	1	1-13	125	34		ER-20
BT40-ER20-125-M	2	1-13	125	28	32	ER-20
BT40-ER20-150	2	1-13	150	34	40	ER-20
BT40-ER20-150-M	2	1-13	150	28	35	ER-20
BT40-ER20-200	2	1-13	200	34	42	ER-20
BT40-ER25-70	1	1-16	70	42		ER-25
BT40-ER25-100	1	1-16	100	42		ER-25
BT40-ER25-125	1	1-16	125	42		ER-25
BT40-ER25-150	2	1-16	150	42	48	ER-25
BT40-ER25-200	2	1-16	200	42	50	ER-25
BT40-ER32-70	1	2-20	70	50		ER-32
BT40-ER32-100	1	2-20	100	50		ER-32
BT40-ER32-125	1	2-20	125	50		ER-32
BT40-ER32-150	2	2-20	150	50	55	ER-32
BT40-ER32-200	2	2-20	200	50	55	ER-32
BT40-ER40-80	1	2-26	80	63		ER-40
BT40-ER40-100	1	2-26	100	63		ER-40
BT40-ER40-125	1	2-26	125	63		ER-40
BT40-ER40-150	1	2-26	150	63		ER-40
BT40-ER40-200	1	2-26	200	63		ER-40
BT50-ER16-100	1	0.5-10	100	28		ER-16
BT50-ER16-125	1	0.5-10	125	28		ER-16
BT50-ER16-150	2	0.5-10	150	28	32	ER-16
BT50-ER16-200	2	0.5-10	200	28	34	ER-16
BT50-ER16-250	2	0.5-10	250	28	36	ER-16
BT50-ER20-100	1	1-13	100	34		ER-20
BT50-ER20-100-M	1	1-13	100	28		ER-20
BT50-ER20-125	1	1-13	125	34		ER-20
BT50-ER20-150	2	1-13	150	34	40	ER-20
BT50-ER20-150-M	2	1-13	150	28	32	ER-20
BT50-ER20-200	2	1-13	200	34	42	ER-20
BT50-ER20-250	2	1-13	250	34	45	ER-20
BT50-ER20-300	2	1-13	300	34	48	ER-20
BT50-ER25-100	1	1-16	100	42		ER-25



### ER 筒夾

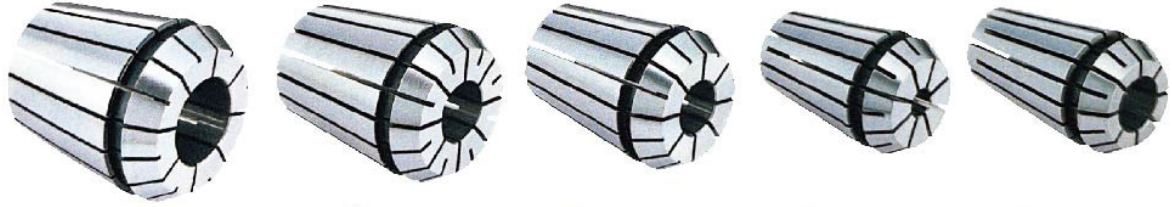

ER11		ER16		ER20		ER25		ER32		ER40	
品號	Range(mm)	品號	Range(mm)	品號	Range(mm)	品號	Range(mm)	品號	Range(mm)	品號	Range(mm)
ER11-1.0	1.0-0.5	ER16-1	1.0-0.5	ER20-2	2-1	ER25-2	2-1	ER32-3	3-2	ER40-3	3-2
ER11-1.5	1.5-1.0	ER16-2	2-1	ER20-3	3-2	ER25-3	3-2	ER32-4	4-3	ER40-4	4-3
ER11-2.0	2.0-1.5	ER16-3	3-2	ER20-4	4-3	ER25-4	4-3	ER32-5	5-4	ER40-5	5-4
ER11-2.5	2.5-2.0	ER16-4	4-3	ER20-5	5-4	ER25-5	5-4	ER32-6	6-5	ER40-6	6-5
ER11-3.0	3.0-2.5	ER16-5	5-4	ER20-6	6-5	ER25-6	6-5	ER32-7	7-6	ER40-7	7-6
ER11-3.5	3.5-3.0	ER16-6	6-5	ER20-7	7-6	ER25-7	7-6	ER32-8	8-7	ER40-8	8-7
ER11-4.0	4.0-3.5	ER16-7	7-6	ER20-8	8-7	ER25-8	8-7	ER32-9	9-8	ER40-9	9-8
ER11-4.5	4.5-4.0	ER16-8	8-7	ER20-9	9-8	ER20-9	9-8	ER32-10	10-9	ER40-10	10-9
ER11-5.0	5.0-4.5	ER16-9	9-8	ER20-10	10-9	ER25-10	10-9	ER32-11	11-10	ER40-11	11-10
ER11-5.5	5.5-5.0	ER16-10	10-9	ER20-11	11-10	ER25-11	11-10	ER32-12	12-11	ER40-12	12-11
ER11-6.0	6.0-5.5	ER16-2.5	2.5-2.0	ER20-12	12-11	ER25-12	12-11	ER32-13	13-12	ER40-13	13-12
ER11-6.5	6.5-6.0	ER16-3.5	3.5-3.0	ER20-13	13-12	ER25-13	13-12	ER32-14	14-13	ER40-14	14-13
ER11-7.0	7.0-6.5	ER16-4.5	4.5-4.0	ER20-2.5	2.5-2.0	ER25-14	14-13	ER32-15	15-14	ER40-15	15-14
		ER16-5.5	5.5-5.0	ER20-3.5	3.5-3.0	ER25-15	15-14	ER32-16	16-15	ER40-16	16-15
		ER16-6.5	6.5-6.0	ER20-4.5	4.5-4.0	ER25-16	16-15	ER32-17	17-16	ER40-17	17-16
		ER16-7.5	7.5-7.0	ER20-5.5	5.5-5.0			ER32-18	18-17	ER40-18	18-17
		ER16-8.5	7.5-8.0	ER20-6.5	6.5-6.0			ER32-19	19-18	ER40-19	19-18
		ER16-9.5	9.5-9.0	ER20-7.5	7.5-7.0			ER32-20	20-19	ER40-20	20-19
			9.5-9.0	ER20-8.5	8.5-8.0					ER40-21	21-20
				ER20-9.5	9.5-9.0					ER40-22	22-21
				ER20-10.5	10.5-10.0					ER40-23	23-22
				ER20-11.5	11.5-11.0					ER40-24	24-23
				ER20-12.5	12.5-12.0					ER40-25	25-24
										ER40-26	26-25

Type	ER11	ER16	ER20	ER21	ER22	ER23
C1	11.5	17	21	26	33	41
L	18	27	31	35	40	46

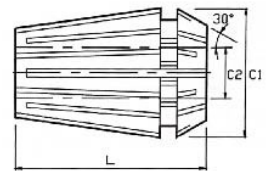

D(mm)	L	DIN6499		
		class	classA	classG
1.0-1.4	6	0.015	0.01	0.005
1.5-2.9	10	0.015	0.01	0.005
3.0-5.9	16	0.015	0.01	0.005
6.0-9.9	25	0.015	0.01	0.005
10.0-17.9	40	0.02	0.015	0.01
18.0-26.9	50	0.02	0.015	0.01
27.0-34.9	60	0.02	0.015	0.01

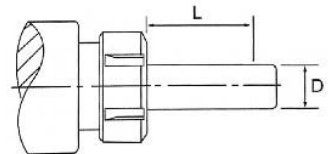

※本牌價依市場行情依於折扣優惠，歡迎查詢價格 94  
The discount will be offered based on current prices. Welcome to check the prices.







● **PSK 直柄筒夾刀桿**

品 號	夾持範圍	ØD	ØD1	L
C20-PSK10-050	Ø 2-10	30	20	50
C20-PSK10-120				120
C20-PSK10-150				150
C20-PSK13-150	Ø 3-13	37	25	150
C20-PSK10-200	Ø 2-10	30		200
C20-PSK13-200	Ø 3-13	37	200	
C32-PSK16-150	Ø 3-16	42	32	150
C32-PSK16-250				250
C32-PSK16-400				400
C42-PSK20-150	Ø 3-20	51	42	150
C42-PSK20-250				250
C42-PSK20-400				400
C42-PSK25-250				250
C42-PSK25-400	Ø 4-25	56	400	

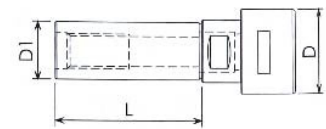

機械刀桿系列

MECHANICAL KNIFE BAR SERIES

● **PSK-G 直柄筒夾刀桿**

品 號	夾持範圍	ØD	ØD1	L
C20-PSK10-050G	Ø 2-10	30	20	50
C20-PSK10-120G				120
C20-PSK10-150G				150
C20-PSK13-150G	Ø 3-13	35	25	150
C20-PSK10-200G	Ø 2-10	30		200
C20-PSK13-200G	Ø 3-13	35	200	
C32-PSK16-150G	Ø 3-16	40	32	150
C32-PSK16-250G				250
C32-PSK16-400G				400
C42-PSK20-150G	Ø 3-20	50	42	150
C42-PSK20-250G				250
C42-PSK20-400G				400
C42-PSK25-250G				250
C42-PSK25-400G	Ø 4-25	55	400	

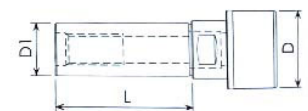

● SLA 側固式刀把

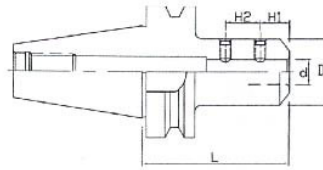

FIG.1

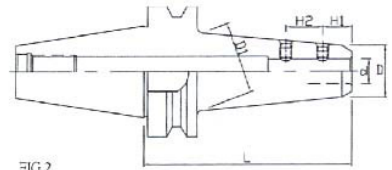

FIG.2

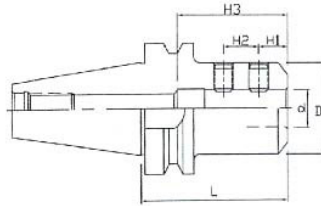

FIG.3

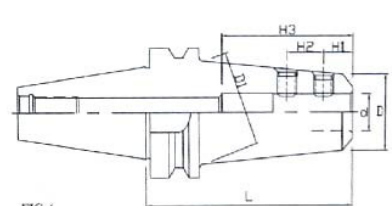

FIG.4

品 號	Fig	Ød	ØD	ØD1	L	H1	H2	H3	G
BT30-SLA6-60	1	6	25		60	9	10		M6
BT30-SLA8-60	1	8	30		60	12	12		M8
BT30-SLA10-60	3	10	34		60	15	12	40	M8
BT30-SLA12-60	3	12	38		60	18	16	46	M10
BT30-SLA16-70	3	16	45		70	20	18	50	M10
BT30-SLA20-75	3	20	45		75	23	20	60	M12
BT30-SLA25-75	3	25	48		75	24	25	66	M12
BT40-SLA6-75	1	6	25		75	9	10		M6
BT40-SLA6-105	2	6	20	25	105	9	10		M6
BT40-SLA6-120	2	6	20	25	120	9	10		M6
BT40-SLA6-150	2	6	20	30	150	9	10		M6
BT40-SLA8-75	1	8	30		75	12	12		M8
BT40-SLA8-105	2	8	25	30	105	12	12		M8
BT40-SLA8-120	2	8	25	30	120	12	12		M8
BT40-SLA8-150	2	8	25	32	150	12	12		M8
BT40-SLA10-75	1	10	34		75	15	12		M8
BT40-SLA10-105	2	10	28	32	105	12	12		M8
BT40-SLA10-120	2	10	28	32	120	15	12		M8
BT40-SLA10-150	2	10	28	35	150	15	12		M8
BT40-SLA12-75	1	12	38		75	18	16		M10
BT40-SLA12-105	2	12	35	38	105	18	16		M10
BT40-SLA12-120	2	12	35	40	120	18	16		M10
BT40-SLA12-150	2	12	35	40	150	18	16		M10
BT40-SLA16-75	3	16	45		75	20	18	50	M10
BT40-SLA16-120	4	16	40	45	120	20	18	50	M10
BT40-SLA16-150	4	16	40	45	150	20	18	50	M10
BT40-SLA20-90	3	20	50		90	23	20	60	M12
BT40-SLA20-120	4	20	47	52	120	23	20	60	M12
BT40-SLA20-150	4	20	47	52	150	23	20	60	M12
BT40-SLA25-90	3	25	57		90	24	25	66	M16



品 號	Fig	Ød	ØD	ØD1	L	H1	H2	H3	G
BT40-SLA25-120	4	25	55	60	120	24	25	66	M16
BT40-SLA25-150	4	25	55	60	150	24	25	66	M16
BT40-SLA32-90	3	32	60		90	24	28	70	M16
BT40-SLA32-120	3	32	60		120	24	28	70	M16
BT40-SLA32-150	3	32	60		150	24	28	70	M16
BT40-SLA40-105	3	40	72		105	24	28	78	M16
BT40-SLA42-105	3	42	72		105	24	28	78	M16
BT50-SLA8-105	1	8	28		105	12	12		M8
BT50-SLA8-150	2	8	25	30	150	12	12		M8
BT50-SLA8-200	2	8	25	35	200	12	12		M8
BT50-SLA10-105	1	10	34		105	15	12		M8
BT50-SLA10-150	2	10	30	35	150	15	12		M8
BT50-SLA10-200	2	10	30	40	200	15	12		M8
BT50-SLA12-105	1	12	40		105	18	16		M10
BT50-SLA12-150	2	12	35	40	150	18	16		M10
BT50-SLA12-150(M)	2	12	30	35	150	18	16		M10
BT50-SLA12-200	2	12	35	45	200	18	16		M10
BT50-SLA12-200(M)	2	12	30	40	200	18	16		M10
BT50-SLA12-200(S)	2	12	25	35	200	18	16		M10
BT50-SLA16-105	1	16	45		105	20	18		M10
BT50-SLA16-150	2	16	40	45	150	20	18		M10
BT50-SLA16-150(M)	2	16	35	40	150	20	18		M10
BT50-SLA16-200	2	16	40	50	200	20	18		M10
BT50-SLA16-200(M)	2	16	35	45	200	20	18		M10
BT50-SLA16-200(S)	2	16	30	40	200	20	18		M10
BT50-SLA16-250	2	16	40	50	250	20	18		M10
BT50-SLA16-250(M)	2	16	35	45	250	20	18		M10
BT50-SLA16-250(T)	2	16	30	45	250	20	18		M10
BT50-SLA20-105	2	20	50		105	23	20	60	M12
BT50-SLA20-150	3	20	45	50	150	23	20	80	M12
BT50-SLA20-150(M)	3	20	40	45	150	23	20	80	M10
BT50-SLA20-200	3	20	45	55	200	23	20	80	M12
BT50-SLA20-200(M)	3	20	40	50	200	23	20	80	M12
BT50-SLA20-200(T)	3	20	35	45	200	23	20	80	M10
BT50-SLA20-250	3	20	45	55	250	23	20	80	M12
BT50-SLA20-250(M)	3	20	40	50	250	23	20	80	M12
BT50-SLA20-250(S)	3	20	35	45	250	23	20	80	M10
BT50-SLA20-250(T)	3	20	35	50	250	23	20	80	M10
BT50-SLA20-300	3	20	45	55	300	23	20	80	M12
BT50-SLA20-300(M)	3	20	40	50	300	23	20	80	M12
BT50-SLA20-300(S)	3	20	35	45	300	23	20	80	M10
BT50-SLA20-300(T)	3	20	35	50	300	23	20	80	M10
BT50-SLA25-105	3	25	60		105	24	24	66	M16
BT50-SLA25-150	3	25	55	60	150	24	24	80	M16
BT50-SLA25-150(M)	3	25	50	55	150	24	24	80	M16
BT50-SLA25-200	3	25	55	65	200	24	24	80	M16





● SLP 側固式刀把

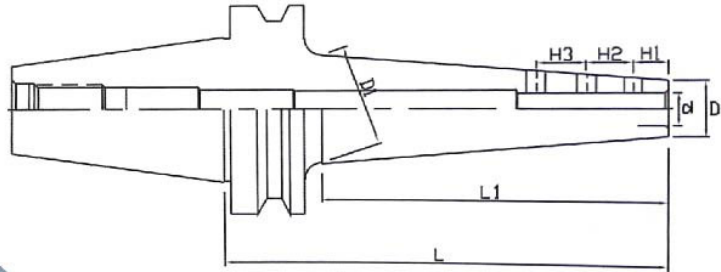

品 號	Ød	ØD	ØD1	L	L1	H1	H2	H3	G
BT50-SLP10-200	10	17	42	200	152	15	20		M6
BT50-SLP12-200	12	22	47.9	200	154	15	16	16	M8
BT50-SLP12-250	12	22	54.6	250	204	15	16	16	M8
BT50-SLP16-200	16	26	51.6	200	154	15	20	22	M8
BT50-SLP16-250	16	26	58.6	250	204	15	20	22	M8
BT50-SLP20-200	20	30	55.6	200	154	15	20	25	M8
BT50-SLP20-250	20	30	62.6	250	204	15	20	25	M8

● SLB 側固式刀把

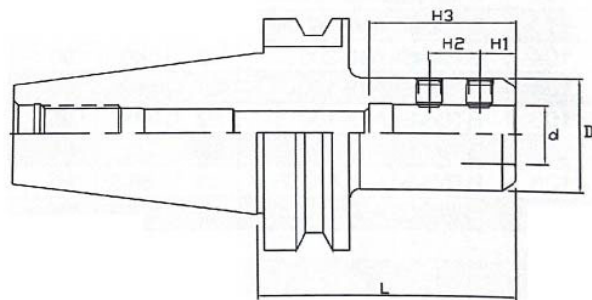
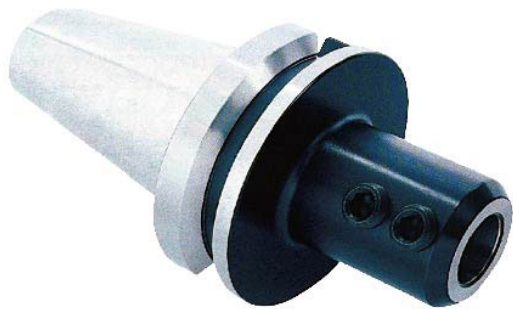

品 號	Ød	ØD	L	H1	H2	H3	G
BT40-SLB20-75	20	48	75	14	15	55	M10
BT40-SLB25-75	25	48	75	15	20	60	M12
BT40-SLB32-75	32	60	75	16	22	65	M16
BT50-SLB20-90	20	48	90	14	15	55	M10
BT50-SLB25-105	25	48	105	15	20	60	M12
BT50-SLB32-105	32	63	105	16	22	65	M16
BT50-SLB40-105	40	68	105	16	25	75	M16





● **DCM 強力型刀把**

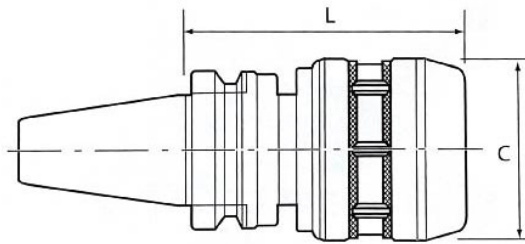

機械刀桿系列

MECHANICAL KNIFE BAR SERIES

品 號	夾持能力	L	C	COLLET
BT30-DCM16-70	4-16	70	42	C16
BT40-DCM16-75	4-16	75	42	C16
BT40-DCM16-90	4-16	90	42	C16
BT40-DCM16-105	4-16	105	42	C16
BT50-DCM16-105	4-16	105	42	C16
BT50-DCM16-135	4-16	135	42	C16
BT50-DCM16-165	4-16	165	42	C16
BT50-DCM16-200	4-16	200	42	C16
BT30-DCM20-80	6-20	80	52	C20
BT40-DCM20-75	6-20	75	52	C20
BT40-DCM20-105	6-20	105	52	C20
BT40-DCM20-135	6-20	135	52	C20
BT50-DCM20-105	6-20	105	52	C20
BT50-DCM20-135	6-20	135	52	C20
BT50-DCM20-165	6-20	165	52	C20

品 號	夾持能力	L	C	COLLET
BT50-DCM20-200	6-20	200	52	C20
BT30-DCM25-80	6-25	80	60	C25
BT40-DCM25-75	6-25	75	60	C25
BT40-DCM25-105	6-25	105	60	C25
BT50-DCM25-105	6-25	105	60	C25
BT50-DCM25-135	6-25	135	60	C25
BT50-DCM25-165	6-25	165	60	C25
BT30-DCM32-100	6-32	100	68	C32
BT40-DCM32-105	6-32	105	68	C32
BT40-DCM32-95	6-32	95	68	C32
BT40-DCM32-135	6-32	135	68	C32
BT50-DCM32-105	6-32	105	68	C32
BT50-DCM32-135	6-32	135	68	C32
BT50-DCM32-165	6-32	165	68	C32
BT50-DCM32-200	6-32	200	68	C32

● 直筒夾

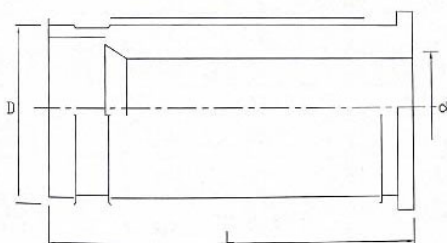

品 號	規 格	(Ø)D	(Ø)d	L
SC16	C16	16	4,6,8,10,12	48
SC20	C20	20	6,8,10,12,16	57
SC25	C25	25	6,8,10,12,16,20	60
SC32	C32	32	6,8,10,12,16,20,25	67
SC32	C32	32	4,5,7,9,11,13,14,15,17,18,19,21,22,23,24	67
SC32	C32	32	1/4", 5/16", 3/8", 1/2", 5/8", 3/4", 1"	67
SC42	C42	42	6,8,10,12,16,20,25,32	76

## ● FMA 平面面銑刀把

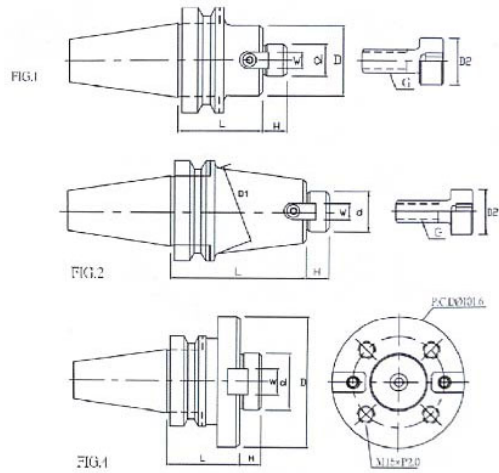

品 號	Fig	Ød	L	H	G	W	ØD	ØD1
BT30-FMA25.4-45	1	25.4	45	19	M12	9.5	45	45
BT30-FMA25.4-60	1	25.4	60	19	M12	9.5	45	45
BT40-FMA25.4-45	1	25.4	45	19	M12	9.5	55	55
BT40-FMA25.4-60	1	25.4	60	19	M12	9.5	55	55
BT40-FMA25.4-75	1	25.4	75	19	M12	9.5	55	55
BT40-FMA25.4-90	2	25.4	90	19	M12	9.5	55	60
BT40-FMA25.4-105	2	25.4	105	19	M12	9.5	55	60
BT40-FMA25.4-125	2	25.4	125	19	M12	9.5	55	60
BT40-FMA25.4-150	2	25.4	150	19	M12	9.5	55	60
BT40-FMA25.4-200	2	25.4	200	19	M12	9.5	55	60
BT40-FMA31.75-45	1	31.75	45	21	M12	12.7	60	60
BT40-FMA31.75-60	1	31.75	60	21	M12	12.7	60	60
BT40-FMA31.75-75	1	31.75	75	21	M12	12.7	60	60
BT40-FMA31.75-90	1	31.75	90	21	M12	12.7	60	60
BT40-FMA31.75-105	1	31.75	105	21	M12	12.7	60	60
BT40-FMA31.75-125	1	31.75	125	21	M12	12.7	60	60
BT40-FMA31.75-150	2	31.75	150	21	M12	12.7	60	68
BT40-FMA31.75-200	2	31.75	200	21	M12	12.7	60	68
BT40-FMA38.1-60	1	38.1	60	23	M16	15.9	78	78
BT50-FMA25.4-45	1	25.4	45	19	M12	9.5	63	63
BT50-FMA25.4-60	1	25.4	60	19	M12	9.5	58	58
BT50-FMA25.4-75	2	25.4	75	19	M12	9.5	58	63
BT50-FMA25.4-90	2	25.4	90	19	M12	9.5	58	63
BT50-FMA25.4-75(S)	2	25.4	75	19	M12	9.5	49	53
BT50-FMA25.4-90(S)	2	25.4	90	19	M12	9.5	49	53
BT50-FMA25.4-105	2	25.4	105	19	M12	9.5	58	63
BT50-FMA25.4-125	2	25.4	125	19	M12	9.5	58	63
BT50-FMA25.4-105(S)	2	25.4	105	19	M12	9.5	49	53
BT50-FMA25.4-125(S)	2	25.4	125	19	M12	9.5	49	53
BT50-FMA25.4-150	2	25.4	150	19	M12	9.5	58	63

品 號	Fig	Ød	L	H	G	W	ØD	ØD1
BT50-FMA25.4-175	2	25.4	175	19	M12	9.5	58	63
BT50-FMA25.4-150(S)	2	25.4	150	19	M12	9.5	49	53
BT50-FMA25.4-175(S)	2	25.4	150	19	M12	9.5	49	53
BT50-FMA25.4-200	2	25.4	200	19	M12	9.5	58	63
BT50-FMA25.4-225	2	25.4	200	19	M12	9.5	58	63
BT50-FMA25.4-250	2	25.4	250	19	M12	9.5	58	63
BT50-FMA25.4-300	2	25.4	300	19	M12	9.5	58	63
BT50-FMA25.4-350	2	25.4	350	19	M12	9.5	58	63
BT50-FMA25.4-400	2	25.4	400	19	M12	9.5	58	63
BT50-FMA25.4-450	2	25.4	450	19	M12	9.5	58	63
BT50-FMA25.4-500	2	25.4	500	19	M12	9.5	58	63
BT50-FMA25.4-600	2	25.4	600	19	M12	9.5	58	63
BT50-FMA31.75-45	1	31.75	45	21	M16	12.7	70	70
BT50-FMA31.75-75	1	31.75	75	21	M16	12.7	70	70
BT50-FMA31.75-75(S)	2	31.75	75	21	M16	12.7	60	65
BT50-FMA31.75-90	1	31.75	90	21	M16	12.7	70	70
BT50-FMA31.75-105	2	31.75	105	21	M16	12.7	70	75
BT50-FMA31.75-105(S)	2	31.75	105	21	M16	12.7	60	65
BT50-FMA31.75-125	2	31.75	125	21	M16	12.7	70	75
BT50-FMA31.75-150	2	31.75	150	21	M16	12.7	70	75
BT50-FMA31.75-125(S)	2	31.75	125	21	M16	12.7	60	65
BT50-FMA31.75-150(S)	2	31.75	150	21	M16	12.7	60	65
BT50-FMA31.75-175	2	31.75	175	21	M16	12.7	70	75
BT50-FMA31.75-200	2	31.75	200	21	M16	12.7	70	75
BT50-FMA31.75-175(S)	2	31.75	175	21	M16	12.7	60	65
BT50-FMA31.75-200(S)	2	31.75	200	21	M16	12.7	60	65
BT50-FMA31.75-225	2	31.75	225	21	M16	12.7	70	75
BT50-FMA31.75-225(S)	2	31.75	225	21	M16	12.7	60	65
BT50-FMA31.75-250	2	31.75	250	21	M16	12.7	82	86
BT50-FMA31.75-300	2	31.75	300	21	M16	12.7	82	86
BT50-FMA31.75-350	2	31.75	350	21	M16	12.7	82	86
BT50-FMA31.75-400	2	31.75	400	21	M16	12.7	82	86
BT50-FMA38.1-45	1	38.1	45	23	M16	15.9	82	82
BT50-FMA38.1-75	1	38.1	75	23	M16	15.9	80	80
BT50-FMA38.1-105	1	38.1	105	23	M16	15.9	80	80
BT50-FMA38.1-125	2	38.1	125	23	M16	15.9	80	85
BT50-FMA38.1-150	2	38.1	150	23	M16	15.9	80	85
BT50-FMA38.1-200	2	38.1	200	23	M16	15.9	80	85
BT50-FMA50.8-45	1	50.8	45	24	M16	19	95	95
BT50-FMA50.8-75	1	50.8	75	24	M16	19	95	95
BT50-FMA50.8-105	1	50.8	105	24	M16	19	95	95
BT50-FMA50.8-125	1	50.8	125	24	M16	19	95	95
BT50-FMA50.8-150	1	50.8	150	24	M16	19	95	95
BT50-FMA47.625-75	4	47.625	75	32		25.4	128	

## ● FMB 平面面銑刀把

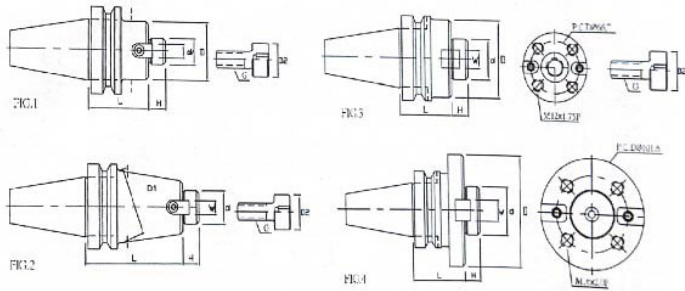
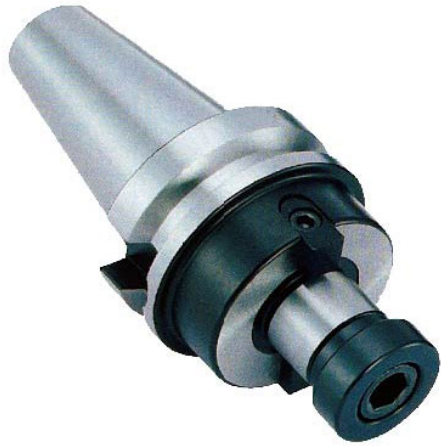

品 號	Fig	Ød	L	H	G	W	ØD	ØD1
BT30-FMB22-45	1	22	45	18	M10	10	45	45
BT30-FMB22-60	1	22	60	18	M10	10	45	45
BT30-FMB27-45	1	27	45	20	M12	12	45	45
BT30-FMB27-60	1	27	60	20	M12	12	45	45
BT30-FMB32-60	1	32	60	21	M16	14	58	58
BT40-FMB22-60	1	22	60	18	M10	10	45	45
BT40-FMB22-75	1	22	75	18	M10	10	45	45
BT40-FMB22-90	2	22	90	18	M10	10	45	50
BT40-FMB22-105	2	22	105	18	M10	10	45	50
BT40-FMB22-125	2	22	125	18	M10	10	45	50
BT40-FMB22-150	2	22	150	18	M10	10	45	50
BT40-FMB22-200	2	22	200	18	M12	10	45	50
BT40-FMB27-60	1	27	60	20	M12	12	55	55
BT40-FMB27-75	1	27	75	20	M12	12	55	55
BT40-FMB27-90	2	27	90	20	M12	12	55	60
BT40-FMB27-105	2	27	105	20	M12	12	55	60
BT40-FMB32-60	1	32	60	21	M16	14	60	60
BT40-FMB32-75	1	32	75	21	M16	14	60	60
BT40-FMB32-90	1	32	90	21	M16	14	60	60
BT40-FMB32-105	1	32	105	21	M16	14	60	60
BT40-FMB40-60	1	40	60	23	M16	15.9	78	78
BT50-FMB22-60	1	22	60	18	M10	10	45	45
BT50-FMB22-75	1	22	75	18	M10	10	45	45
BT50-FMB22-90	1	22	90	18	M10	10	45	45
BT50-FMB22-105	2	22	105	18	M10	10	45	50
BT50-FMB22-105(H)	2	22	105	18	M10	10	58	52
BT50-FMB22-125	2	22	125	18	M10	10	45	50
BT50-FMB22-150	2	22	150	18	M10	10	45	50
BT50-FMB22-150(T)	2	22	150	18	M10	10	49	54
BT50-FMB22-150(H)	2	22	150	18	M10	10	58	62

品 號	Fig	Ød	L	H	G	W	ØD	ØD1
BT50-FMB22-175	2	22	150	18	M10	10	45	50
BT50-FMB22-175(H)	2	22	150	18	M10	10	49	55
BT50-FMB22-200	2	22	200	18	M10	10	45	50
BT50-FMB22-200(T)	2	22	200	18	M10	10	49	56
BT50-FMB22-200(H)	2	22	200	18	M10	10	58	62
BT50-FMB22-250	2	22	250	18	M10	10	45	50
BT50-FMB22-250(T)	2	22	250	18	M10	10	49	59
BT50-FMB22-250(H)	2	22	250	18	M10	10	58	62
BT50-FMB22-300	2	22	300	18	M10	10	45	50
BT50-FMB22-300(T)	2	22	300	18	M10	10	49	62
BT50-FMB22-300(H)	2	22	300	18	M10	10	58	62
BT50-FMB22-350	2	22	350	18	M10	10	45	50
BT50-FMB22-350(T)	2	22	350	18	M10	10	49	62
BT50-FMB22-350(H)	2	22	350	18	M10	10	58	62
BT50-FMB22-400	2	22	400	18	M10	10	45	50
BT50-FMB22-400(T)	2	22	400	18	M10	10	49	68
BT50-FMB22-450	2	22	450	18	M10	10	45	50
BT50-FMB22-450(T)	2	22	450	18	M10	10	49	70
BT50-FMB22-500(H)	2	22	500	18	M10	10	58	62
BT50-FMB22-600(H)	2	22	600	18	M10	10	58	62
BT50-FMB27-60	1	27	60	20	M12	12	60	60
BT50-FMB27-75	1	27	75	20	M12	12	60	60
BT50-FMB27-90	1	27	90	20	M12	12	60	60
BT50-FMB27-105	2	27	105	20	M12	12	60	65
BT50-FMB27-125	2	27	125	20	M12	12	60	65
BT50-FMB27-150	2	27	150	20	M12	12	60	65
BT50-FMB27-200	2	27	200	20	M12	12	60	65
BT50-FMB27-250	2	27	250	20	M12	12	60	65
BT50-FMB27-300	2	27	300	20	M12	12	60	65
BT50-FMB32-60	1	32	60	21	M16	14	70	70
BT50-FMB32-75	1	32	75	21	M16	14	70	70
BT50-FMB32-90	1	32	90	21	M16	14	70	70
BT50-FMB32-105	2	32	105	21	M16	14	70	75
BT50-FMB32-125	2	32	125	21	M16	14	70	75
BT50-FMB32-150	2	32	150	21	M16	14	70	75
BT50-FMB32-200	2	32	200	21	M16	14	70	75
BT50-FMB40-60	1	40	60	23	M16	16	80	80
BT50-FMB40-75(F)	3	40	75	23		16	90	
BT50-FMB40-75	1	40	75	23	M16	16	80	80
BT50-FMB40-90	1	40	90	23	M16	16	80	80
BT50-FMB40-105	1	40	105	23	M16	16	80	80
BT50-FMB40-125	2	40	125	23	M16	16	80	85
BT50-FMB40-150	2	40	150	23	M16	16	80	85
BT50-FMB60-75	4	60	75	32		25.4	128	

## ● LR-20 光電式尋邊器



### 產品特色

- 1.亮度無死角，目測容易
- 2.精度：0.005m/m
- 3.附UM-5,1.5V電池x2只

規格	柄徑	測頭	總長
LR-20	Ø20	158	Ø10
LR-32	Ø32	158	Ø10

## ● ME-420 尋邊器

## ● ME-1020 尋邊器



- 配合轉速：400-600PRM

規格	測頭	總長	精度
ME-420	Ø4,Ø10	90	±0.002
ME-1020	Ø10	81	±0.002

## ● SR-10T 尋邊器 SR-10T



### 產品特色

- 1.配合轉速：800-1000PRM
- 2.精度：0.005m/m內

規格	柄徑	測頭	長度
SR-10T	Ø10	Ø5	Ø95
	Ø10	Ø5	Ø145

● MITUTOYO 游標卡尺

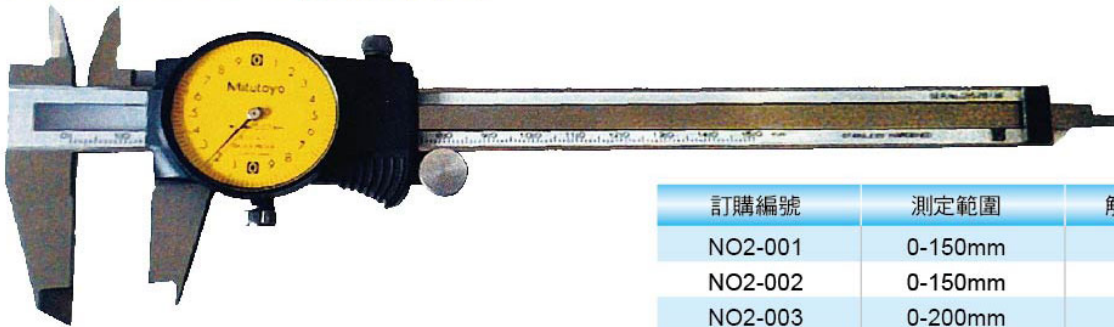

訂購編號	測定範圍	解析度(mm)
NO2-001	0-150mm	0.05
NO2-002	0-150mm	0.02
NO2-003	0-200mm	0.02
NO2-004	0-300mm	0.02
NO2-005	0-150mm	0.01
NO2-006	0-200mm	0.01

● TESA 游標卡尺

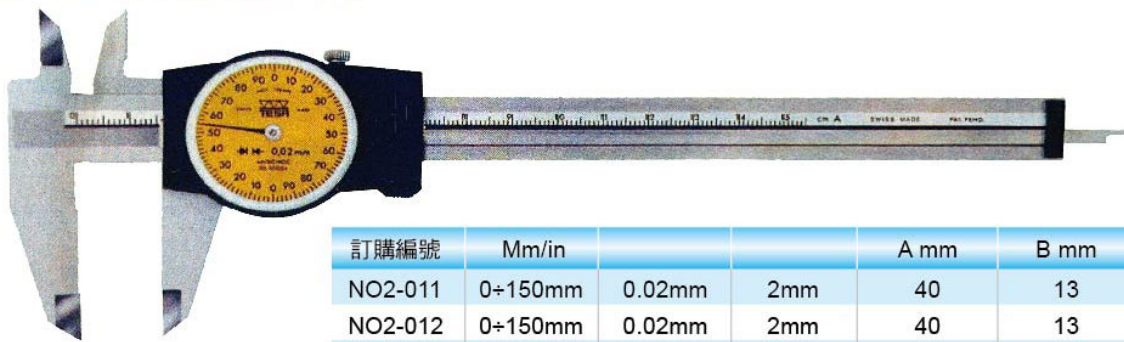

訂購編號	Mm/in			A mm	B mm	C mm
NO2-011	0+150mm	0.02mm	2mm	40	13	74
NO2-012	0+150mm	0.02mm	2mm	40	13	74
NO2-013	0+150mm	0.01mm	1mm	40	13	74
NO2-014	0+200mm	0.02mm	2mm	50	18.6	89.5
NO2-015	0+300mm	0.02mm	2mm	64	20.6	105.5

● TESA 防水卡尺



訂購編號	mm/in	RS232	A mm	B mm	C mm	g
NO2-021	150/6	—	40	16	71.5	140
NO2-022	105/6	—	40	16	71.5	140
NO2-023	200/8	—	50	20	89.5	200
NO2-024	300/12	—	64	22	105.5	270

## ● MITUTOYO 外徑測微器

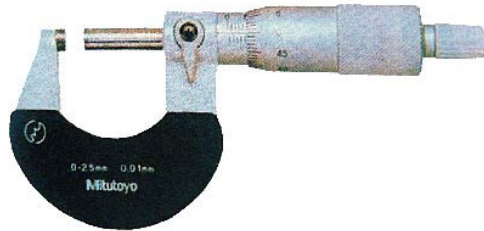

品號	測定範圍	解析度(mm)
103-137	0-25mm	0.01mm
103-138	25-50mm	0.01mm
130-139	50-75mm	0.01mm
130-140	75-100mm	0.01mm

## ● GIROD 槓桿量表



品號	讀數	測定範圍	錶徑
G-1252	0.01	0.8	28.4
G-1452	0.01	0.8	38.2
G-1253	0.002	0.2	28.4
G-1453	0.002	0.2	38.2
G-1254	0.01	0.5	28.4
G-1454	0.01	0.5	38.2

## ● MITUTOYO 槓桿量表

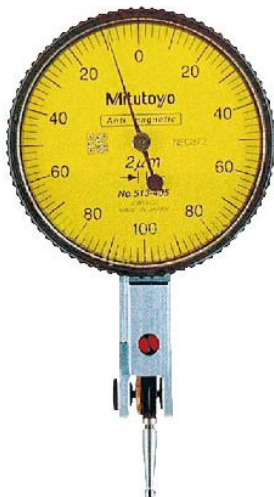

品號	讀數	測定範圍
513-424	0.01	0.5
513-404	0.01	0.8
513-405	0.002	0.2
513-425	0.002	0.6

● Z 軸設定器



ZOP-50(光電式)(Optical Type)



ZOPS-50(光電鳴音式)  
(Optical & Sound Type)



ZIPS-50(附表式)(Indicator Type)



ZAP-50(附表式)(Indicator Type)

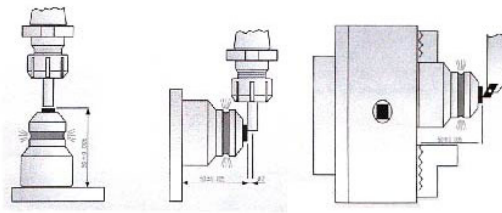

產品特色

- 1.總高度50m/m，伸縮3m/m。
- 2.底座附永久磁鐵，容易附著。
- 3.刀具接觸時，紅燈會亮。
- 4.精度0.002m/m
- 5.ZOP-50價格：
- 6.ZOPS-50價格：

產品特色

- 1.總高度50m/m，伸縮3.5m/m。
- 2.附百分表可做歸零校正，最小刻劃為0.01m/m。
- 3.ZIP-50價格：
- 4.ZIP-50A價格：

產品特色

- 1.總高度50m/m，伸縮3m/m。
- 2.本體直徑68Øm/m。
- 3.附百分表可做歸零校正，最小刻劃為0.01m/m。
- 4.ZAP-50價格：

## PM粉末螺旋絲攻

適用於一般難切削材料，高強度合金鋼、碳鋼和不銹鋼的盲孔加工，可攻至HRC40°，且易於排屑。原裝TiCN鍍膜可提高使用效能及延長絲攻的使用壽命。



規格
M 2x0.4
M 2.5x0.45
M 3x0.5
M 3.5x0.6
M 4x0.7
M 5x0.8
M 6x1.0

規格
M 8x1.25
M 10x1.25
M 10x1.5
M 12x1.5
M 12x1.75
M 14x1.5
M 14x2.0

規格
M 16x1.5
M 16x2.0
M 18x1.5
M 18x2.5
M 20x1.5
M 20x2.5
M 22x1.5

規格
M 22x2.5
M 24x1.5
M 24x3.0
M 27x1.5
M 27x3.0
M 30x1.5
M 30x3.5

## PM粉末先端絲攻

規格
M 2x0.4
M 2.5x0.45
M 3x0.5
M 3.5x0.6
M 4x0.7
M 5x0.8
M 6x1.0

規格
M 8x1.25
M 10x1.25
M 10x1.5
M 12x1.5
M 12x1.75
M 14x1.5
M 14x2.0

規格
M 16x1.5
M 16x2.0
M 18x1.5
M 18x2.5
M 20x1.5
M 20x2.5
M 22x1.5

規格
M 22x2.5
M 24x1.5
M 24x3.0
M 27x1.5
M 27x3.0
M 30x1.5
M 30x3.5



## 多用途環帶螺旋絲攻

優異的性能適用於各種加工材質，特殊的螺紋溝槽設計可防止切削堵塞，延長絲攻的使用壽命。



REGAL



規格
M 2x0.4
M 2.5x0.45
M 2.6x0.45
M 3x0.5
M 3.5x0.6
M 4x0.7
M 5x0.8
M 6x1.0
M 8x1.25
M 10x1.25

規格
M 10x1.5
M 12x1.25
M 12x1.5
M 12x1.75
M 14x1.5
M 14x2.0
M 16x1.5
M 16x2.0
M 18x1.5
M 18x2.5

規格
M 20x1.5
M 20x2.5
M 22x1.5
M 22x2.5
M 24x1.5
M 24x3.0
M 27x1.5
M 27x3.5
M 30x1.5
M 30x3.5

規格
W 1/8-40
W 5/32-32
W 3/16-24
W 1/4-20
W 5/16-18
W 3/8-16
W 1/2-12
W 5/8-11
W 3/4-10
W 7/8-9
W 1"-8

### ● 多用途環帶先端絲攻

優異的性能適用於各種加工材質，特殊的螺紋溝槽設計可防止切削堵塞，延長絲攻的使用壽命。



規格
M 2x0.4
M 2.5x0.45
M 2.6x0.45
M 3x0.5
M 3.5x0.6
M 4x0.7
M 5x0.8
M 6x1.0
M 8x1.25
M 10x1.25

規格
M 10x1.5
M 12x1.25
M 12x1.5
M 12x1.75
M 14x1.5
M 14x2.0
M 16x1.5
M 16x2.0
M 18x1.5
M 18x2.5

規格
M 20x1.5
M 20x2.5
M 22x1.5
M 22x2.5
M 24x1.5
M 24x3.0
M 27x1.5
M 27x3.5
M 30x1.5
M 30x3.5

規格
W 1/8-40
W 5/32-32
W 3/16-24
W 1/4-20
W 5/16-18
W 3/8-16
W 1/2-12
W 5/8-11
W 3/4-10
W 7/8-9
W 1"-8

### ● 銅鋁專用螺旋絲攻

適用於鋁、鎂、鋅、銅及有色金屬的盲孔加工。



規格
M 2x0.4
M 2.5x0.45
M 2.6x0.45
M 3x0.5
M 3x0.6
M 3.5x0.6
M 4x0.7

規格
M 4x0.75
M 5x0.8
M 5x0.9
M 6x1.0
M 8x1.25
M 8x1.25
M 10x1.5

規格
M 12x1.25
M 12x1.5
M 12x1.75
M 14x1.5
M 14x2.0
M 16x1.5
M 16x2.0

規格
M 18x1.5
M 18x2.5
M 22x2.5
M 24x3.0
M 26x1.5



- TSP T系列螺旋絲攻
- TSP-TiN T系列鍍鈦螺旋絲攻
- TSP-SUS T系列不鏽鋼螺旋絲攻
  
- TSP-3H T系列高硬度鋼用螺旋絲攻
- TSP-LH T系列左螺旋絲攻
- O-TSP T系列加大螺旋絲攻



絲攻系列

WIRE TAP SERIES

公制牙(M)	精度	形狀寸法 mm		
		全長L	牙長ℓ	柄徑d
M2.0x0.4	GT3	40	8	3
M2.3x0.4	GT3	42	9.5	3
M2.5x0.45	GT3	44	9.5	3
M2.6x0.45	GT3	44	9.5	3
M3.0x0.5	GT6	46	5	4
M3.0x0.5	GT8	46	5	4
M3.0x0.6	GT6	46	5	4
M3.5x0.6	GT6	48	6	4
M4.0x0.5	GT6	52	7	5
M4.0x0.7	GT6	52	7	5
M4.0x0.7	GT8	52	7	5
M4.0x0.75	GT6	52	7	5
M5.0x0.5	GT6	60	8	5.5
M5.0x0.8	GT6	60	8	5.5
M5.0x0.8	GT8	60	8	5.5
M5.0x0.9	GT6	60	8	5.5
M6.0x0.5	GT6	62	10	6
M6.0x0.75	GT6	62	10	6
M6.0x1.0	GT6	62	10	6
M6.0x1.0	GT9	62	10	6

公制牙(M)	精度	形狀寸法 mm		
		全長L	牙長ℓ	柄徑d
M7.0x0.75	GT6	65	10	6.2
M7.0x1.0	GT6	65	10	6.2
M8.0x0.5	GT6	70	12	6.2
M8.0x0.75	GT7	70	12	6.2
M8.0x1.0	GT7	70	12	6.2
M8.0x1.25	GT7	70	12	6.2
M8.0x1.25	GT10	70	12	6.2
M9.0x1.0	GT7	72	12	7
M9.0x1.25	GT7	72	12	7
M10x0.5	GT6	75	15	7
M10x0.75	GT7	75	15	7
M10x1.0	GT7	75	15	7
M10x1.25	GT7	75	15	7
M10x1.25	GT11	75	15	7
M10x1.5	GT7	75	15	7
M10x1.5	GT11	75	15	7
M12x1.0	GT8	82	17	8.5
M12x1.25	GT8	82	17	8.5
M12x1.25	GT12	82	17	8.5
M12x1.5	GT8	82	17	8.5

公制牙(M)	精度	形狀寸法 mm		
		全長L	牙長ℓ	柄徑d
M12x1.5	GT12	82	17	8.5
M12x1.75	GT8	82	17	8.5
M12x1.75	GT12	82	17	8.5
M14x1.0	GT8	88	20	10.5
M14x1.25	GT8	88	20	10.5
M14x1.5	GT8	88	20	10.5
M14x2.0	GT8	88	20	10.5
M15x1.5	GT8	90	15	10.5
M16x1.0	GT8	95	20	12.5
M16x1.5	GT8	95	20	12.5
M16x2.0	GT8	95	20	12.5
M17x1.0	GT8	95	15	13
M17x1.5	GT8	95	15	13
M18x1.0	GT8	100	25	14
M18x1.5	GT8	100	25	14
M18x2.0	GT9	100	25	14
M18x2.5	GT9	100	25	14
M20x1.0	GT8	105	25	15
M20x1.5	GT8	105	25	15
M20x2.0	GT9	105	25	15

公制牙(M)	精度	形狀寸法 mm		
		全長L	牙長ℓ	柄徑d
M20x2.5	GT9	105	25	15
M22x1.0	GT8	115	25	17
M22x1.5	GT8	115	25	17
M22x2.0	GT9	115	25	17
M22x2.5	GT9	115	25	17
M24x1.0	GT8	120	30	19
M24x1.5	GT8	120	30	19
M24x2.0	GT9	120	30	19
M24x3.0	GT9	120	30	19
M25x1.5	GT8	125	20	19
M25x2.0	GT9	125	20	19
M26x1.5	GT8	125	20	20
M27x1.5	GT8	130	30	20
M27x2.0	GT9	130	30	20
M27x3.0	GT9	130	30	20
M28x1.5	GT8	130	20	21
M28x2.0	GT9	130	20	21
M30x1.5	GT8	135	35	23
M30x3.5	GT9	135	35	23

- TGN T系列先端絲攻
- TGN-TiN T系列鍍鈦先端絲攻
- TGN-SUS T系列不鏽鋼用先端絲攻
- O-TGN T系列加大先端絲攻

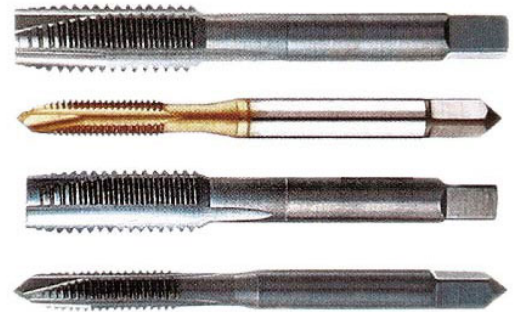

公制牙(M)	精度	形狀寸法 mm		
		全長L	牙長ℓ	柄徑d
M2.0x0.4	GT3	40	8	3
M2.0x0.4	GT5	40	8	3
M2.3x0.4	GT3	42	9.5	3
M2.3x0.4	GT5	42	9.5	3
M2.5x0.45	GT3	44	9.5	3
M2.6x0.45	GT3	44	9.5	3
M2.6x0.45	GT5	44	9.5	3
M3.0x0.5	GT5	46	11	4
M3.0x0.5	GT7	46	11	4
M3.0x0.6	GT5	46	11	4
M3.5x0.6	GT5	48	13	4
M4.0x0.5	GT5	52	13	5
M4.0x0.7	GT5	52	13	5
M4.0x0.7	GT7	52	13	5
M4.0x0.75	GT5	52	13	5
M5.0x0.5	GT5	60	16	5.5

公制牙(M)	精度	形狀寸法 mm		
		全長L	牙長ℓ	柄徑d
M10x1.5	GT9	75	24	7
M11x1.0	GT6	80	25	8
M11x1.25	GT6	80	25	8
M11x1.5	GT8	80	25	8
M12x1.0	GT7	82	29	8.5
M12x1.25	GT8	82	29	8.5
M12x1.25	GT10	82	29	8.5
M12x1.5	GT7	82	29	8.5
M12x1.5	GT9	82	29	8.5
M12x1.75	GT8	82	29	8.5
M12x1.75	GT10	82	29	8.5
M14x1.0	GT7	88	30	10.5
M14x1.25	GT7	88	30	10.5
M14x1.5	GT7	88	30	10.5
M14x2.0	GT8	88	30	10.5
M16x1.0	GT7	95	32	12.5

公制牙(M)	精度	形狀寸法 mm		
		全長L	牙長ℓ	柄徑d
M5.0x0.8	GT6	60	16	5.5
M5.0x0.8	GT8	60	16	5.5
M5.0x0.9	GT6	60	16	5.5
M6.0x0.75	GT5	62	19	6
M6.0x1.0	GT6	60	19	6
M6.0x1.0	GT8	60	19	6
M7.0x1.0	GT6	65	19	6.2
M8.0x1.0	GT6	70	22	6.2
M8.0x1.25	GT6	70	22	6.2
M8.0x1.25	GT8	75	22	6.2
M9.0x1.25	GT6	72	22	7
M10x1.0	GT6	75	24	7
M10x1.25	GT6	75	24	7
M10x1.25	GT8	75	24	7
M10x1.5	GT7	75	24	7

公制牙(M)	精度	形狀寸法 mm		
		全長L	牙長ℓ	柄徑d
M16x1.5	GT7	95	32	12.5
M16x2.0	GT8	95	32	12.5
M18x1.0	GT7	100	37	14
M18x1.5	GT8	100	37	14
M18x2.0	GT8	100	37	14
M18x2.5	GT9	100	37	14
M20x1.0	GT7	105	37	15
M20x1.5	GT8	105	37	15
M20x2.0	GT8	105	37	15
M20x2.5	GT9	105	37	15
M22x1.5	GT8	115	38	17
M22x2.0	GT8	115	38	17
M22x2.5	GT9	115	38	17
M24x1.5	GT8	120	45	19
M24x3.0	GT9	120	45	19
M27x1.5	GT8	130	45	20



## ● 銅用無溝絲攻

適用於碳鋼、合金鋼、調質鋼和SUS等有韌性材質的盲孔加工。



規格	精度	型號
M 2x0.4	GH4	P·B
M 2.3x0.4	GH4	B
M 2.5x0.45	GH5	P·B
M 2.6x0.45	GH5	P·B
M 3x0.5	GH6	P·B
M 3.5x0.6	GH6	P·B
M 4x0.7	GH7	P·B
M 5x0.8	GH7	P·B
M 6x1.0	GH7	P·B
M 8x1.25	GH7	B
M 10x1.25	GH7	B

P型：適用於穿孔  
B型：適用於盲孔

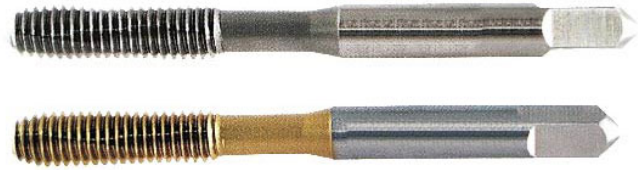

規格	精度	型號
UNC 2-56	GH4	P·B
UNC 4-40	GH5	P·B
UNC 6-32	GH5,6,7	P·B
UNC 8-30	GH7	P·B
UNC 10-24	GH7	P·B
UNC 12-24	GH7	P·B
UNC 1/4-20	GH7	B
UNF 10-32	GH6,7	P·B

P型：適用於穿孔  
B型：適用於盲孔

## ● 無溝絲攻

適用於鋁、鎂、銅及有色金屬的加工。



規格	精度	型號
M 2x0.4	GH4	P·B
M 2.3x0.4	GH4	B
M 2.5x0.45	GH5	P·B
M 2.6x0.45	GH5	P·B
M 3x0.5	GH6	P·B
M 3.5x0.6	GH6	P·B
M 4x0.7	GH7	P·B
M 5x0.8	GH7	P·B
M 6x1.0	GH7	P·B
M 8x1.25	GH7	B
M 10x1.25	GH7	B

P型：適用於穿孔  
B型：適用於盲孔

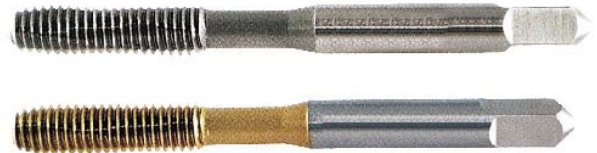

規格	精度	型號
UNC 2-56	GH4	P·B
UNC 4-40	GH5	P·B
UNC 6-32	GH5,6,7	P·B
UNC 8-30	GH7	P·B
UNC 10-24	GH7	P·B
UNC 12-24	GH7	P·B
UNC 1/4-20	GH7	B
UNF 10-32	GH6,7	P·B

P型：適用於穿孔  
B型：適用於盲孔

絲攻系列  
WIRE TAP SERIES

### ● 長柄螺旋絲攻

適用於深孔之碳鋼、合金鋼的盲孔加工，  
具有優異的排屑效果。



#### >100mm

規格
M 3x0.5
M 4x0.7
M 5x0.8
M 6x1.25
M 8x1.25
M 10x1.25
M 10x1.5
M 12x1.25
M 12x1.5
M 12x1.75
M 14x1.0
M 14x1.5
M 14x2.0

#### >120mm

規格
M 3x0.5
M 4x0.7
M 5x0.8
M 6x1.0
M 8x1.25
M 10x1.25
M 10x1.5
M 12x1.25
M 12x1.5
M 12x1.75
M 14x1.5
M 14x2.0
M 16x1.5
M 26x2.0

#### >150mm

規格
M 3x0.5
M 4x0.7
M 5x0.8
M 6x1.0
M 8x1.25
M 10x1.25
M 10x1.5
M 12x1.25
M 12x1.5
M 12x1.75
M 14x1.5
M 14x2.0
M 16x1.5
M 16x2.0
M 18x1.5
M 18x2.5
M 20x1.5
M 20x2.5
M 22x1.5
M 22x2.5
M 24x1.5
M 24x3.0

#### >200mm

規格
M 12x1.75
M 14x2.0
M 16x1.5
M 16x2.0
M 18x1.5
M 18x2.5
M 20x1.5
M 20x2.5
M 22x1.5
M 22x2.5
M 24x1.5
M 24x3.0

### ● 長柄螺旋絲攻(W UNC系列)

適用於深孔之碳鋼、合金鋼的盲孔加工，  
具有優異的排屑效果。



#### >100mm

規格
W 1/8-40
W 5/32-32
W 3/16-24
W 1/4-20
W 5/16-18
W 3/8-16
W 1/2-12

#### >120mm

規格
W 5/32-32
W 3/16-24
W 1/4-20
W 5/16-18
W 3/8-16
W 1/2-12
W 5/8-11

#### >150mm

規格
W 5/32-32
W 3/16-24
W 1/4-20
W 5/16-18
W 3/8-16
W 1/2-12
W 5/8-11
W 3/4-10
W 7/8-9
W 1~8

#### >200mm

規格
W 5/8-11
W 3/4-10
W 7/8-9
W 1~8



## ● 高速鋼螺旋絲攻 HSS Spiral Flute Taps

適用於碳鋼和合金鋼的盲孔加工，  
具有優異的排屑。



### 美制粗牙UNC

### 美制細牙UNF

規格
W 1/8-40
W 5/32-32
W 3/16-24
W 1/4-20
W 5/16-18
W 3/8-16
W 7/16-14
W 1/2-12
W 9/16-12
W 5/8-11
W 3/4-10
W 7/8-9
W 1" - 8
W 1" 1/8 - 7
W 1" 1/4 - 7
W 1" 3/8 - 6
W 1" 1/2 - 6
W 1" 3/4 - 5
W 1" 7/8 - 4 1/2
W 2" - 4 1/2

規格
UNC 2 - 56
UNC 3 - 48
UNC 4 - 40
UNC 5 - 40
UNC 6 - 32
UNC 8 - 32
UNC 10 - 24
UNC 12 - 24
UNC 3/16 - 24
UNC 1/4 - 20
UNC 5/16 - 8
UNC 3/8 - 16
UNC 7/16 - 14
UNC 1/2 - 13
UNC 9/16 - 12
UNC 5/8 - 11
UNC 3/4 - 10
UNC 7/8 - 9
UNC 1" - 8
UNC 1" 1/8 - 7
UNC 1" 1/4 - 7
UNC 1" 1/2 - 6
UNC 2" - 4 1/2

規格
UNF 3 - 56
UNF 4 - 48
UNF 5 - 44
UNF 6 - 40
UNF 8 - 36
UNF 10 - 32
UNF 12 - 28
UNF 5/32 - 36
UNF 3/16 - 32
UNF 1/4 - 28
UNF 5/16 - 24
UNF 3/8 - 24
UNF 7/16 - 20
UNF 1/2 - 20
UNF 9/16 - 18
UNF 5/8 - 18
UNF 3/4 - 16
UNF 7/8 - 14
UNF 1" - 12
UNF 1" - 14
UNF 1" 1/8 - 12
UNF 1" 1/4 - 12
UNF 1" 1/2 - 12
UNF 2" - 12

絲攻系列  
WIRE TAP SERIES

### 加工材料適用說明

低碳鋼 ◎	中碳鋼 ○	高碳鋼 ○	合金鋼 □	硬化鋼 □	不鏽鋼 ○	工具鋼 ○	鑄鋼 ○	鑄鋼 □	高強度鑄鋼 □	◎：優 ○：良
銅 □	黃銅 □	鑄銅 □	鋁 □	鑄鋁 □	鑄鎂 □	鑄鋅 □	鈦合金 □	鎳合金 □	熱固性塑料 □	熱塑性塑料 ○

● MHSS PS 直牙管牙絲攻

適用於直管內部的螺紋加工



規格	規格	規格
PS 1/8-28	PS 1/2-14	PS 1"1/4-11
PS 1/4-19	PS 3/4-14	PS 1"1/2-11
PS 3/8-19	PS 1"- 11	PS 2"-11

● MHSS PT 斜牙管牙絲攻

適用於錐管內部的螺紋加工



規格	規格	規格
PT 1/8-28	PT 1/2-14	PT 1"1/4-11
PT 1/4-19	PT 3/4-14	PT 1"1/2-11
PT 3/8-19	PT 1"- 11	PT 2"-11

● MHSS PF 直牙管牙絲攻

適用於直管內部的螺紋加工



規格	規格	規格
PF 1/8-28	PF 1/2-14	PF 1"1/4-11
PF 1/4-19	PF 3/4-14	PF 1"1/2-11
PF 3/8-19	PF 1"- 11	

● MHSS NPS 直牙管牙絲攻

適用於直管內部的螺紋加工



規格	規格	規格
NPS 1/8-27	NPS 1/2-14	NPS1"1/4-11 1/2
NPS 1/4-18	NPS 3/4-14	NPS1"1/2-11 1/2
NPS 3/8-18	NPS 1"- 11 1/2	NPS2"11 1/2

● 螺旋PS 直牙管牙絲攻

適用於直管內部的螺紋加工，螺旋槽設計，易於排屑。



規格	規格	規格
PS 1/8-28	PS 1/2-14	PS 1"1/4-11
PS 1/4-19	PS 3/4-14	PS 1"1/2-11
PS 3/8-19	PS 1"- 11	PS 2"-11

● 螺旋PT 斜牙管牙絲攻

適用於錐管內部的螺紋加工，螺旋槽設計，易於排屑。



規格	規格	規格
PT 1/8-28	PT 1/2-14	PT 1"1/4-11
PT 1/4-19	PT 3/4-14	PT 1"1/2-11
PT 3/8-19	PT 1"- 11	PT 2"-11



## ● PS 直牙長柄管牙絲攻

適用於深孔之直管內部的螺紋加工



### >100mm

規格
PS 1/8-28
PS 1/4-19
PS 3/8-19

### >120mm

規格
PS 1/8-28
PS 1/4-19
PS 3/8-19
PS 1/2-14

### >150mm

規格
PS 1/8-28
PS 1/4-19
PS 3/8-19

規格
PS 1/2-14
PS 3/4-14
PS 1"-11

### >200mm

規格
PS 3/4-14
PS 1"-11

絲攻系列

WIRE TAP SERIES

## ● PT 斜牙長柄管牙絲攻

適用於深孔之直管內部的螺紋加工



### >100mm

規格
PS 1/8-28
PS 1/4-19
PS 3/8-19

### >120mm

規格
PS 1/8-28
PS 1/4-19
PS 3/8-19
PS 1/2-14

### >150mm

規格
PS 1/8-28
PS 1/4-19
PS 3/8-19

規格
PS 1/2-14
PS 3/4-14
PS 1"-11

### >200mm

規格
PS 3/4-14
PS 1"-11

● 超鈷鋼標準立銑刀-2刃型

適用於開槽、側銑、模具等一般加工，2刃設計用於銑槽。



刀徑	柄徑	刃長	全長
1.0	6	2.5	55
1.5	6	4	55
2.0	6	6	55
2.5	6	7	55
3.0	6	10	55
3.5	8	12	60
4.0	6	12	65
4.0	8	12	60
4.5	8	15	65
5.0	8	15	65
5.5	8	15	65
6.0	6	15	60
6.0	8	15	65
6.5	10	20	75

m/m



刀徑	柄徑	刃長	全長
7.0	10	20	75
7.5	10	20	75
8.0	10	21	75
8.5	10	25	80
9.0	10	25	80
9.5	10	25	80
10.0	10	26	80
10.5	12	30	90
11.0	12	30	90
11.5	12	30	90
12.0	12	31	90
12.5	12	35	95
14.0	16	35	100
15.0	16	40	105

m/m

● 超鈷鋼標準立銑刀-2刃型

適用於開槽、側銑、模具等一般加工，2刃設計用於銑槽。



刀徑	柄徑	刃長	全長
16.0	16	40	105
17.0	16	40	105
18.0	16	40	105
19.0	20	45	115
20.0	20	45	115
21.0	20	45	115
22.0	20	45	115
23.0	25	50	125
24.0	25	50	125
25.0	25	50	125
26.0	25	50	125
17.0	25	55	120
28.0	25	55	125

m/m

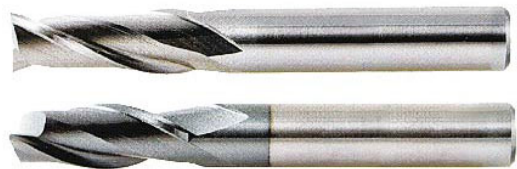

刀徑	柄徑	刃長	全長
29.0	25	55	125
30.0	25	55	105
31.0	32	60	145
32.0	32	60	145
33.0	32	60	145
34.0	32	60	145
35.0	32	60	145
36.0	32	65	150
37.0	32	65	150
38.0	32	65	150
39.0	32	65	150
40.0	32	65	150

m/m

※本牌價依市場行情依於折扣優惠，歡迎查詢價格  
The discount will be offered based on current prices. Welcome to check the prices.



## ● 超鈷鋼標準立銑刀-4刃型

適用於開槽、側銑、模具等一般加工，  
4刃設計可得到良好的表面質量。



刀徑	柄徑	刃長	全長
1.5	6	7	50
2.0	6	10	50
2.5	6	10	50
3.0	6	10	50
3.5	8	12	60
4.0	8	12	60
4.5	8	15	60
5.0	8	15	60
5.5	8	15	60
6.0	8	15	60
7.0	10	20	60
8.0	10	20	60
9.0	10	25	70
10.0	10	25	70
11.0	12	30	80
12.0	12	30	80
13.0	12	35	85
14.0	16	35	90
15.0	16	40	95
16.0	16	40	95
17.0	16	40	95
18.0	16	40	95

m/m

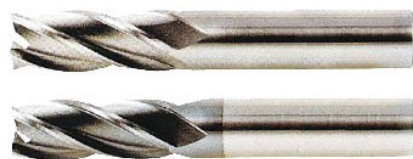

刀徑	柄徑	刃長	全長
19.0	20	45	110
20.0	20	45	110
21.0	20	45	110
22.0	20	45	110
23.0	25	50	120
24.0	25	50	120
25.0	25	50	120
26.0	25	50	120
27.0	25	55	125
28.0	25	55	125
29.0	25	55	125
30.0	25	55	125
31.0	32	60	145
32.0	32	60	145
33.0	32	60	145
34.0	32	60	145
35.0	32	60	145
36.0	32	65	150
37.0	32	65	150
38.0	32	65	150
39.0	32	65	150
40.0	32	65	150

m/m

## ● 超鈷鋼長刃立銑刀-2刃型

適用於開槽、側銑、模具等一般加工，2刃設計用於銑槽，  
加長型設計可用更深、更寬的切削。



刀徑	柄徑	刃長	全長
2.0	6	10	60
3.0	6	15	60
4.0	6	20	65
5.0	8	25	75
6.0	8	25	75
7.0	10	35	90
8.0	10	35	90
9.0	10	45	100
10.0	10	45	100
11.0	12	55	115
12.0	12	55	115
13.0	12	55	115
14.0	16	55	120
15.0	16	65	130
16.0	16	65	130

m/m

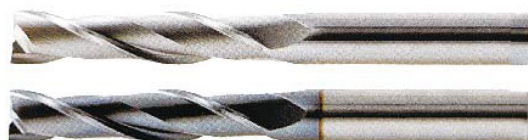

刀徑	柄徑	刃長	全長
17.0	16	65	130
18.0	16	65	130
19.0	20	75	145
20.0	20	75	145
21.0	20	75	145
22.0	20	75	145
23.0	25	90	165
24.0	25	90	165
25.0	25	90	165
26.0	25	90	165
27.0	25	90	165
28.0	25	90	165
29.0	25	90	165
30.0	25	90	165

m/m

### ● 超鈷鋼長刃立銑刀-4刃型

適用於開槽、側銑、模具等一般加工，  
4刃設計可得到良好的表面質量。



刀徑	柄徑	刃長	全長
3.0	6	15	60
4.0	8	20	70
5.0	8	25	75
6.0	8	25	75
7.0	10	35	90
8.0	10	35	90
9.0	10	45	100
10.0	10	45	100
11.0	12	55	115
12.0	12	55	115
13.0	12	55	115
14.0	16	55	120
15.0	16	65	130
16.0	16	65	130

m/m

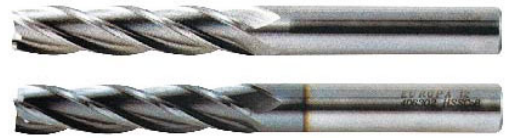

刀徑	柄徑	刃長	全長
17.0	16	65	130
18.0	16	65	130
19.0	20	75	145
20.0	20	75	145
21.0	20	75	145
22.0	20	75	145
23.0	25	90	165
24.0	25	90	165
25.0	25	90	165
26.0	25	90	165
27.0	25	90	165
28.0	25	90	165
29.0	25	90	165
30.0	25	90	165

m/m

### ● 超鈷鋼圓頭立銑刀

適用於銑削圓形底部槽和特殊輪廓，2刃設計在開槽時可提供良好的排屑能力。



內角	刀徑	柄徑	刃長	全長
0.5R	1.0	6	2.5	50
0.75R	1.5	6	4	50
1R	2.0	6	5	50
1.25R	2.5	6	6	60
1.5R	3.0	6	8	60
2R	4.0	6	8	70
2R	4.0	8	8	70
2.5R	5.0	6	10	80
2.5R	5.0	8	10	80
3R	6.0	6	12	90
3R	6.0	8	12	90
3.5R	7.0	8	14	90
4R	8.0	8	14	100
4R	8.0	10	20	75

m/m



內角	刀徑	柄徑	刃長	全長
4.5R	9.0	10	18	100
5R	10.0	10	18	100
5.5R	11.0	12	22	100
6R	12.0	12	22	110
6.5R	13.0	12	26	110
7R	14.0	12	26	110
7.5R	15.0	12	30	110
8R	16.0	16	30	140
8.5R	17.0	16	34	140
9R	18.0	16	34	140
9.5R	19.0	16	38	140
10R	20.0	20	38	160
12.5R	25.0	25	50	180

m/m



## ● 超鈷鋼粗銑刀

這種通用的粗銑刀是一種設計給高度生產(生產率高)的金屬切削工具，適用於切削碳鋼和合金鋼。



刀徑	柄徑	刃長	全長	刃數
6.0	8	15	60	4
7.0	10	20	65	4
8.0	10	20	65	4
9.0	12	25	75	4
10.0	10	25	75	4
10.0	12	25	75	4
11.0	12	30	80	4
12.0	12	30	80	4
13.0	16	35	90	4
14.0	16	35	90	4
15.0	16	40	95	4

刀徑公差						
柄徑公差						
	1~3	3~6	6~10	10~18	18~30	30~50
刀刃 js12	±50	±60	±75	±90	±105	±125
柄徑 h6	0	0	0	0	0	0
	-6	-8	-9	-11	-13	-16

## ● 超鈷鋼長刃粗銑刀

這種通用的粗銑刀是一種設計給高度生產(生產率高)的金屬切削工具，適用於切削碳鋼和合金鋼，加長型設計可用於更深、更寬的切削。



刀徑公差						
柄徑公差						
	1~3	3~6	6~10	10~18	18~30	30~50
刀刃 js12	±50	±60	±75	±90	±105	±125
柄徑 h6	0	0	0	0	0	0
	-6	-8	-9	-11	-13	-16

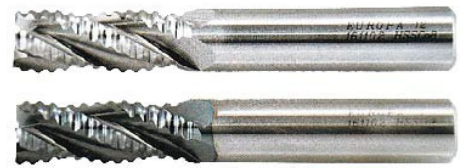

刀徑	柄徑	刃長	全長	刃數
16.0	16	40	95	4
17.0	20	40	105	4
18.0	20	40	105	4
19.0	20	45	110	4
20.0	20	45	110	4
22.0	20	45	110	5
24.0	25	50	120	5
25.0	25	50	120	5
28.0	25	55	125	6
30.0	25	55	125	6
32.0	32	60	145	6

m/m

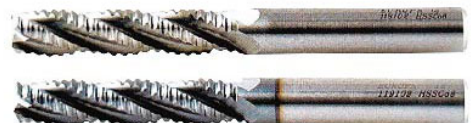

刀徑	柄徑	刃長	全長	刃數
10.0	10	45	95	4
12.0	12	53	110	4
14.0	12	53	110	4
16.0	16	63	123	4
18.0	16	63	123	4
20.0	20	75	141	4
22.0	20	75	141	5
25.0	25	90	166	5
30.0	25	90	166	6

m/m

超鈷鋼粗銑刀系列

SUPER COBALT STEEL ROUGH MILLING CUTTER SERIES

### ● 鎢鋼鑽頭

適用於加工碳鋼、合金鋼、鑄鋼、鑄鐵、冷硬鑄鐵、可鍛鑄鐵、非鐵重金屬、非鐵輕金屬、耐磨塑料等材料。

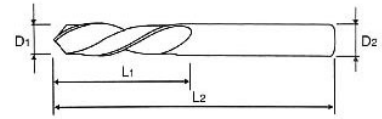

刀徑 D1	刃長 L1	全長 L2
1.0	6	26
1.1	7	28
1.2	8	30
1.3	8	30
1.4	9	32
1.5	9	32
1.6	10	34
1.7	10	34
1.8	11	36
1.9	11	36
2.0	12	38
2.1	12	38
2.2	13	40
2.3	13	40
2.4	14	43
2.5	14	43
2.6	14	43
2.7	16	46

m/m

刀徑 D1	刃長 L1	全長 L2
6.4	31	70
6.5	31	70
6.6	31	70
6.7	31	70
6.8	34	74
6.9	34	74
7.0	34	74
7.1	34	74
7.2	34	74
7.3	34	74
7.4	34	74
7.5	34	74
7.6	37	79
7.7	37	79
7.8	37	79
7.9	37	79
8.0	37	79

刀徑 D1	刃長 L1	全長 L2
2.8	16	46
2.9	16	46
3.0	16	46
3.1	18	49
3.2	18	49
3.3	18	49
3.4	20	49
3.5	20	52
3.6	20	52
3.7	20	52
3.8	20	52
3.9	22	55
4.0	22	55
4.1	22	55
4.2	22	55
4.3	24	58
4.4	24	58
4.5	24	58

m/m

刀徑 D1	刃長 L1	全長 L2
8.1	37	79
8.2	37	79
8.3	37	79
8.4	37	79
8.5	37	79
8.6	40	84
8.7	40	84
8.8	40	84
8.9	40	84
9.0	40	84
9.1	40	84
9.2	40	84
9.3	40	84
9.4	40	84
9.5	40	84
9.6	43	89
9.7	43	89

刀徑 D1	刃長 L1	全長 L2
4.6	24	58
4.7	24	58
4.8	26	62
4.9	26	62
5.0	26	62
5.1	26	62
5.2	26	62
5.3	26	62
5.4	28	66
5.5	28	66
5.6	28	66
5.7	28	66
5.8	28	66
5.9	28	66
6.0	28	66
6.1	31	70
6.2	31	70
6.3	31	70

m/m

刀徑 D1	刃長 L1	全長 L2
9.8	43	89
9.9	43	89
10.0	43	89
10.1	43	89
10.2	43	89
10.3	43	89
10.4	43	89
10.5	43	89
10.6	43	89
10.7	43	89
10.8	43	89
10.9	43	89
11.0	47	95
11.5	47	95
12.0	51	102
12.5	51	102
13.0	51	102

※本牌價依市場行情依於折扣優惠，歡迎查詢價格  
The discount will be offered based on current prices. Welcome to check the prices.



## SG-ESS DRILLS 粉末短鑽

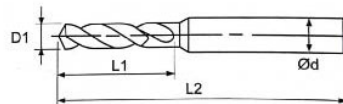

刃徑 1.0-6.8mm

刀徑 D1	刃長 L1	全長 L2	柄徑 Ød	刀徑 D1	刃長 L1	全長 L2	柄徑 Ød	刀徑 D1	刃長 L1	全長 L2	柄徑 Ød
1.0	6	38	3	2.8	16	48	3	4.65	24	68	6
1.05	6	38	3	2.85	16	48	3	4.7	24	68	6
1.1	7	39	3	2.9	16	48	3	4.75	24	68	6
1.15	7	39	3	2.95	16	48	3	4.8	26	70	6
1.2	8	40	3	3.0	16	48	3	4.85	26	70	6
1.25	8	40	3	3.05	18	50	4	4.9	26	70	6
1.3	8	40	3	3.1	18	50	4	4.95	26	70	6
1.35	9	41	3	3.15	18	50	4	5.0	26	70	6
1.4	9	41	3	3.2	18	50	4	5.05	26	70	6
1.45	9	41	3	3.25	18	50	4	5.1	26	70	6
1.5	9	41	3	3.3	18	50	4	5.15	26	70	6
1.55	10	42	3	3.35	18	50	4	5.2	26	70	6
1.6	10	42	3	3.4	20	52	4	5.25	26	70	6
1.65	10	42	3	3.45	20	52	4	5.3	26	70	6
1.7	10	42	3	3.5	20	52	4	5.35	28	72	6
1.75	11	43	3	3.55	20	52	4	5.4	28	72	6
1.8	11	43	3	3.6	20	52	4	5.45	28	72	6
1.85	11	43	3	3.65	20	52	4	5.5	28	72	6
1.9	11	43	3	3.7	20	52	4	5.55	28	72	6
1.95	12	44	3	3.75	20	52	4	5.6	28	72	6
2.0	12	44	3	3.8	22	54	4	5.65	28	72	6
2.05	12	44	3	3.85	22	54	4	5.7	28	72	6
2.1	12	44	3	3.9	22	54	4	5.75	28	72	6
2.15	13	45	3	3.95	22	54	4	5.8	28	72	6
2.2	13	45	3	4.0	22	54	4	5.85	28	72	6
2.25	13	45	3	4.05	22	66	6	5.9	28	72	6
2.3	13	45	3	4.1	22	66	6	5.95	28	72	6
2.35	13	45	3	4.15	22	66	6	6.0	31	72	6
2.4	14	46	3	4.2	22	66	6	6.1	31	75	8
2.45	14	46	3	4.25	22	66	6	6.2	31	75	8
2.5	14	46	3	4.3	24	68	6	6.3	31	75	8
2.55	14	46	3	4.35	24	68	6	6.4	31	75	8
2.6	14	46	3	4.4	24	68	6	6.5	31	75	8
2.65	14	46	3	4.45	24	68	6	6.6	31	75	8
2.7	16	48	3	4.5	24	68	6	6.7	31	75	8
2.75	16	48	3	4.55	24	68	6	6.8	34	78	8

m/m

m/m

m/m

● SG-ESS DRILLS 粉末短鑽

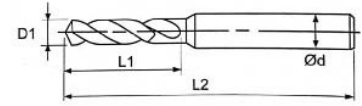

刃徑 6.9-20.0mm

刃徑 D1	刃長 L1	全長 L2	柄徑 Ød
6.9	34	78	8
7.0	34	78	8
7.1	34	78	8
7.2	34	78	8
7.3	34	78	8
7.4	34	78	8
7.5	34	78	8
7.6	37	81	8
7.7	37	81	8
7.8	37	81	8
7.9	37	81	8
8.0	37	81	8
8.1	37	87	10
8.2	37	87	10
8.3	37	87	10
8.4	37	87	10
8.5	37	87	10
8.6	40	90	10
8.7	40	90	10
8.8	40	90	10
8.9	40	90	10
9.0	40	90	10
9.1	40	90	10
9.2	40	90	10
9.3	40	90	10
9.4	40	90	10
9.5	40	90	10
9.6	43	93	10
9.7	43	93	10
9.8	43	93	10
9.9	43	93	10
10.0	43	93	10
10.1	43	100	12
10.2	43	100	12
10.3	43	100	12
10.4	43	100	12

m/m

刃徑 D1	刃長 L1	全長 L2	柄徑 Ød
10.5	43	100	12
10.6	43	100	12
10.7	47	104	12
10.8	47	104	12
10.9	47	104	12
11.0	47	104	12
11.1	47	104	12
11.2	47	104	12
11.3	47	104	12
11.4	47	104	12
11.5	47	104	12
11.6	47	104	12
11.7	47	104	12
11.8	47	104	12
11.9	51	108	12
12.1	51	105	12
12.1	51	105	12
12.2	51	108	12
12.3	51	108	12
12.4	51	108	12
12.5	51	108	12
12.6	51	108	12
12.7	51	108	12
12.8	51	108	12
12.9	51	108	12
13.0	51	108	12
13.5	72	132	16
14.0	72	132	16
14.5	76	136	16
15.1	76	142	20
15.5	80	146	20
16.0	80	146	20
16.5	84	150	20
17.0	84	150	20
17.5	87	153	20
18.0	87	153	20

m/m

刃徑 D1	刃長 L1	全長 L2	柄徑 Ød
18.5	90	156	20
19.0	90	164	25
19.5	94	168	25
20.0	94	168	25

m/m



● SG-ES DRILLS 粉末長鑽

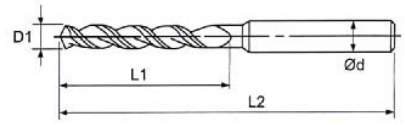

刃徑 2.0-9.5mm

刀徑 D1	刀長 L1	全長 L2	柄徑 Ød
2.0	24	56	3
2.1	24	56	3
2.2	25	56	3
2.3	25	56	3
2.4	30	61	3
2.5	30	61	3
2.6	30	61	3
2.7	33	64	3
2.8	33	64	3
2.9	33	64	3
3.0	33	64	3
3.1	36	68	4
3.2	36	68	4
3.3	36	68	4
3.4	39	71	4
3.5	39	71	4
3.6	39	71	4
3.7	39	71	4
3.8	43	75	4
3.9	43	75	4
4.0	43	75	4
4.1	43	85	6
4.2	43	85	6
4.3	47	89	6
4.4	47	89	6
4.5	47	89	6
4.6	47	89	6
4.7	47	89	6
4.8	52	94	6
4.9	52	94	6
5.0	52	94	6
5.1	52	94	6
5.2	52	94	6
5.3	52	94	6
5.4	57	99	6
5.5	57	99	6
5.6	57	99	6
5.7	57	99	6

m/m

刀徑 D1	刀長 L1	全長 L2	柄徑 Ød
5.8	57	99	6
5.9	57	99	6
6.0	57	99	8
6.1	63	107	8
6.2	63	107	8
6.3	63	107	8
6.4	63	107	8
6.5	63	107	8
6.6	63	107	8
6.7	63	107	8
6.8	69	113	8
6.9	39	113	8
7.0	69	113	8
7.1	69	113	8
7.2	69	113	8
7.3	69	113	8
7.4	69	113	8
7.5	69	113	8
7.6	75	119	8
7.7	75	119	8
7.8	75	119	8
7.9	75	119	8
8.0	75	119	8
8.1	75	125	10
8.2	75	125	10
8.3	75	125	10
8.4	75	125	10
8.5	75	125	10
8.6	81	131	10
8.7	81	131	10
8.8	81	131	10
8.9	81	131	10
9.0	81	131	10
9.1	81	131	10
9.2	81	131	10
9.3	81	131	10
9.4	81	131	10
9.5	81	131	10

m/m

超鈷鋼鑽頭系列  
SUPER COBALT STEEL DRILL BIT SERIES

● SG-ES DRILLS 粉末長鑽

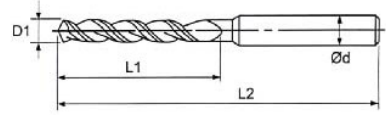

刃徑 9.6-32.0mm

刀徑 D1	刃長 L1	全長 L2	柄徑 Ød
9.6	87	137	10
9.7	87	137	10
9.8	87	137	10
9.9	87	137	10
10.0	87	137	10
10.1	87	144	12
10.2	87	144	12
10.3	87	144	12
10.4	87	144	12
10.5	87	144	12
10.6	87	144	12
10.7	94	151	12
10.8	94	151	12
10.9	94	151	12
11.0	94	151	12
11.1	94	151	12
11.2	94	151	12
11.3	94	151	12
11.4	94	151	12
11.5	94	151	12
11.6	94	151	12
11.7	94	151	12
11.8	94	151	12
11.9	101	158	12
12.0	101	158	12
12.1	101	158	12
12.2	101	158	12
12.3	101	158	12
12.4	101	158	12
12.5	101	158	12
12.6	101	158	12
12.7	101	158	12
12.8	101	158	12
12.9	101	158	12
13.0	101	158	12
13.5	108	168	16
14.0	108	168	16
14.5	114	173	16

m/m

刀徑 D1	刃長 L1	全長 L2	柄徑 Ød
15.0	114	180	20
15.5	120	185	20
16.0	120	185	20
16.5	125	189	20
17.0	125	189	20
17.5	130	194	20
18.0	130	194	20
18.5	135	198	20
19.0	135	206	25
19.5	140	210	25
20.2	140	210	25
20.5	145	214	25
21.0	145	214	25
21.5	150	218	25
22.0	150	218	25
22.5	155	223	25
23.0	155	223	25
23.5	155	223	25
24.0	160	237	32
24.5	160	237	32
25.0	165	241	32
25.5	165	241	32
26.0	165	241	32
26.5	165	241	32
27.0	170	245	32
27.5	170	245	32
28.0	170	245	32
28.5	175	248	32
29.0	175	248	32
29.5	175	248	32
30.3	175	248	32
30.5	180	252	32
31.0	180	252	32
31.5	180	252	32
32.0	185	255	32

m/m

※本牌價依市場行情依於折扣優惠，歡迎查詢價格  
The discount will be offered based on current prices. Welcome to check the prices. 130



## ● HSS Co8 Gold-P 直柄鑽頭 適用於加工不鏽鋼、鈦合金和鍍鉻合金等難切削材料。

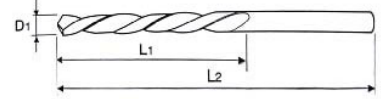

超鈷鋼鑽頭系列 SUPER COBALT STEEL DRILL BIT SERIES

刀徑 D1	刃長 L1	全長 L2
1.0	18	40
1.1	20	42
1.2	20	42
1.3	22	45
1.4	23	48
1.5	23	48
1.6	25	50
1.7	25	50
1.8	28	52
1.9	28	52
2.0	29	55
2.1	29	55
2.2	33	58
2.3	33	58
2.4	35	61
2.5	35	61
2.6	37	64
2.7	37	64
2.8	39	67
2.9	42	71
3.0	42	71

m/m

刀徑 D1	刃長 L1	全長 L2
7.1	75	108
7.2	75	108
7.3	75	108
7.4	78	111
7.5	78	111
7.6	78	111
7.7	81	114
7.8	81	114
7.9	81	114
8.0	81	114
8.1	84	117
8.2	84	117
8.3	84	117
8.4	87	121
8.5	87	121
8.6	87	121
8.7	87	121
8.8	89	124
8.9	89	124
9.0	89	124

m/m

刀徑 D1	刃長 L1	全長 L2
3.1	42	71
3.2	42	71
3.3	45	73
3.4	45	73
3.5	45	73
3.6	48	76
3.7	48	76
3.8	48	76
3.9	51	79
4.0	54	83
4.1	54	83
4.2	54	83
4.3	54	83
4.4	56	86
4.5	56	86
4.6	56	86
4.7	59	89
4.8	59	89
4.9	62	92
5.0	62	92

m/m

刀徑 D1	刃長 L1	全長 L2
9.1	89	124
9.2	92	127
9.3	92	127
9.4	92	127
9.5	92	127
9.6	95	130
9.7	95	130
9.8	95	130
9.9	95	130
10.0	95	130
10.1	98	133
10.2	98	133
10.3	98	133
10.4	98	133
10.5	100	137
10.6	100	137
10.7	100	137
10.8	103	140
10.9	103	140
11.0	103	140

m/m

刀徑 D1	刃長 L1	全長 L2
5.1	62	92
5.2	64	95
5.3	64	95
5.4	64	95
5.5	64	95
5.6	67	98
5.7	67	98
5.8	67	98
5.9	67	98
6.0	70	102
6.1	70	102
6.2	70	102
6.3	70	102
6.4	73	105
6.5	73	105
6.6	73	105
6.7	73	105
6.8	73	105
6.9	73	105
7.0	73	105

m/m

刀徑 D1	刃長 L1	全長 L2
11.1	103	140
11.2	106	143
11.3	106	143
11.4	106	143
11.5	106	143
11.6	109	146
11.7	109	146
11.8	109	146
11.9	109	146
12.0	111	149
12.1	111	149
12.2	111	149
12.3	111	149
12.4	114	152
12.5	114	152
12.6	114	152
12.7	114	152
12.8	114	152
12.9	114	152
13.0	114	152

m/m

131 ※本牌價依市場行情依於折扣優惠，歡迎查詢價格  
The discount will be offered based on current prices. Welcome to check the prices.

● HSS 直柄麻花鑽頭 適用於鋼、鑄鋼合金、非合金鋼、灰鑄鐵、可鍛鑄鐵的深孔鑽削和石墨的加工。



螺旋角：20~30°

刀徑 D1	刃長 L1	全長 L2
1.0	18	40
1.1	20	42
1.2	20	42
1.3	22	45
1.4	23	48
1.5	23	48
1.6	25	50
1.7	25	50
1.8	28	52
1.9	28	52
2.0	29	55
2.1	29	55
2.2	33	58
2.3	33	58
2.4	35	61
2.5	35	61
2.6	37	64
2.7	37	64
2.8	39	67
2.9	42	71
3.0	42	71

m/m

刀徑 D1	刃長 L1	全長 L2
7.1	75	108
7.2	75	108
7.3	75	108
7.4	78	111
7.5	78	111
7.6	78	111
7.7	81	114
7.8	81	114
7.9	81	114
8.0	81	114
8.1	84	117
8.2	84	117
8.3	84	117
8.4	87	121
8.5	87	121
8.6	87	121
8.7	87	121
8.8	89	124
8.9	89	124
9.0	89	124

m/m

刀徑 D1	刃長 L1	全長 L2
3.1	42	71
3.2	42	71
3.3	45	73
3.4	45	73
3.5	45	73
3.6	48	76
3.7	48	76
3.8	48	76
3.9	51	79
4.0	54	83
4.1	54	83
4.2	54	83
4.3	54	83
4.4	56	86
4.5	56	86
4.6	56	86
4.7	59	89
4.8	59	89
4.9	62	92
5.0	62	92

m/m

刀徑 D1	刃長 L1	全長 L2
9.1	89	124
9.2	92	127
9.3	92	127
9.4	92	127
9.5	92	127
9.6	95	130
9.7	95	130
9.8	95	130
9.9	95	130
10.0	95	130
10.1	98	133
10.2	98	133
10.3	98	133
10.4	98	133
10.5	100	137
10.6	100	137
10.7	100	137
10.8	103	140
10.9	103	140
11.0	103	140

m/m

刀徑 D1	刃長 L1	全長 L2
5.1	62	92
5.2	64	95
5.3	64	95
5.4	64	95
5.5	64	95
5.6	67	98
5.7	67	98
5.8	67	98
5.9	67	98
6.0	70	102
6.1	70	102
6.2	70	102
6.3	70	102
6.4	73	105
6.5	73	105
6.6	73	105
6.7	73	105
6.8	73	105
6.9	73	105
7.0	73	105

m/m

刀徑 D1	刃長 L1	全長 L2
11.1	103	140
11.2	106	143
11.3	106	143
11.4	106	143
11.5	106	143
11.6	109	146
11.7	109	146
11.8	109	146
11.9	109	146
12.0	111	149
12.1	111	149
12.2	111	149
12.3	111	149
12.4	114	152
12.5	114	152
12.6	114	152
12.7	114	152
12.8	114	152
12.9	114	152
13.0	114	152

m/m



● 直柄長鑽頭 Straigh Shank Twist Long Drills

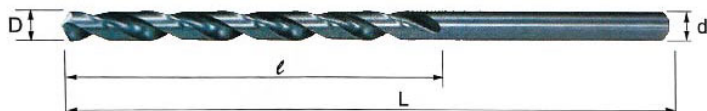

刃徑 1.0-7.6mm

刀徑 D	全長 L	溝長 l	刀徑 D	全長 L	溝長 l	刀徑 D	全長 L	溝長 l	刀徑 D	全長 L	溝長 l
1.0	100	40	3.1	150	75	* 4.6	100	50	6.1	200	100
1.0	150	75	3.1	200	100	4.6	150	75	6.2	150	90
1.1	100	40	3.2	100	50	4.6	200	100	6.2	200	100
1.1	150	75	3.2	150	75	* 4.7	100	50	6.3	150	90
1.2	100	40	3.2	200	100	4.7	150	75	6.3	200	100
1.2	150	75	3.3	100	50	4.7	200	100	6.4	150	90
1.3	100	40	3.3	150	75	* 4.8	100	50	6.4	200	100
1.3	150	75	3.3	200	100	4.8	150	75	6.5	150	90
1.4	100	40	3.4	100	50	4.8	200	100	6.5	200	100
1.4	150	75	3.4	150	75	* 4.9	100	50	6.5	250	125
1.5	100	40	3.4	200	100	4.9	150	75	6.6	150	90
1.5	150	75	3.5	100	50	4.9	200	100	6.6	200	100
1.6	100	40	3.5	150	75	* 5.0	100	50	6.7	150	90
1.6	150	75	3.5	200	100	5.0	150	75	6.7	200	100
1.7	100	50	* 3.6	100	50	5.0	200	100	6.8	150	90
1.7	150	75	3.6	150	75	5.0	250	125	6.8	200	100
1.8	100	50	3.6	200	100	* 5.1	100	50	6.9	150	90
1.8	150	75	* 3.7	100	50	5.1	150	90	6.9	200	100
1.9	100	50	3.7	150	75	5.1	200	100	7.0	150	90
1.9	150	75	3.7	200	100	* 5.2	100	50	7.0	200	100
2.0	100	50	* 3.8	100	50	5.2	150	90	7.0	250	125
2.0	150	75	3.8	150	75	5.2	200	100	7.0	300	150
2.1	100	50	3.8	200	100	* 5.3	100	50	7.1	150	90
2.1	150	75	* 3.9	100	50	5.3	150	90	7.1	200	100
2.2	100	50	3.9	150	75	5.3	200	100	7.1	250	125
2.2	150	75	3.9	200	100	* 5.4	100	50	7.1	300	150
2.3	100	50	4.4	100	50	5.4	150	90	7.2	150	90
2.3	150	75	4.0	150	75	5.4	200	100	7.2	200	100
2.4	100	50	4.0	200	100	* 5.5	100	50	7.2	250	125
2.4	150	75	* 4.1	100	50	5.5	150	90	7.2	300	150
2.5	100	50	4.1	150	75	5.5	200	100	7.3	150	90
2.5	150	75	4.1	200	100	5.5	250	125	7.3	200	100
2.6	100	50	* 4.2	100	50	5.6	150	90	7.3	250	125
2.6	150	75	4.2	150	75	5.6	200	100	7.3	300	150
2.7	100	50	4.2	200	100	5.7	150	90	7.4	150	90
2.7	150	75	* 4.3	100	50	5.7	200	100	7.4	200	100
2.8	100	50	4.3	150	75	5.8	150	90	7.4	250	125
2.8	150	75	4.3	200	100	5.8	200	100	7.4	300	150
2.9	100	50	* 4.4	100	50	5.9	150	90	7.5	150	90
2.9	150	75	4.4	150	75	5.9	200	100	7.5	200	100
3.0	100	50	4.4	200	100	6.0	150	90	7.5	250	125
3.0	150	75	4.5	100	50	6.0	200	100	7.5	300	150
3.0	200	100	4.5	150	75	6.0	150	125	7.6	150	90
3.1	100	50	4.5	200	100	6.1	200	90	7.6	200	125

超鈷鋼鑽頭系列 SUPER COBALT STEEL DRILL BIT SERIES

133 ※ 本牌價依市場行情依於折扣優惠，歡迎查詢價格  
The discount will be offered based on current prices. Welcome to check the prices.

● 直柄長鑽頭 Straigh Shank Twist Long Drills



刃徑 7.6-13.0mm

刃徑 D	全長 L	溝長 ℓ	刃徑 D	全長 L	溝長 ℓ	刃徑 D	全長 L	溝長 ℓ	刃徑 D	全長 L	溝長 ℓ
7.6	250	150	8.8	200	125	* 10.2	300	175	* 11.7	250	150
7.6	300	175	8.8	250	150	* 10.3	200	125	* 11.7	300	175
7.7	150	90	8.8	300	175	* 10.3	250	150	* 11.8	200	125
7.7	200	125	8.9	200	125	* 10.3	300	175	* 11.8	250	150
7.7	250	150	8.9	250	150	* 10.4	200	125	* 11.8	300	175
7.7	300	175	8.9	300	175	* 10.4	250	150	* 11.9	200	125
7.8	150	90	9.0	200	125	* 10.4	300	175	* 11.9	250	150
7.8	200	125	9.0	250	150	10.5	200	125	* 11.9	300	175
7.8	250	150	9.0	300	175	10.5	250	150	12.0	200	125
7.8	300	175	9.1	200	125	10.5	300	175	12.0	250	150
7.9	150	90	9.1	250	150	* 10.6	200	125	12.0	300	175
7.9	200	125	9.1	300	175	* 10.6	250	150	* 12.1	200	125
7.9	250	150	9.2	200	125	* 10.6	300	175	* 12.1	250	150
7.9	300	175	9.2	250	150	* 10.7	200	125	* 12.1	300	175
8.0	150	90	9.2	300	175	* 10.7	250	150	* 12.2	200	125
8.0	200	125	9.3	200	125	* 10.7	300	175	* 12.2	250	150
8.0	250	150	9.3	250	150	* 10.8	200	125	* 12.2	300	175
8.0	300	175	9.3	300	175	* 10.8	250	150	* 12.3	200	125
* 8.1	150	90	9.4	200	125	* 10.8	300	175	* 12.3	250	150
8.1	200	125	9.4	250	150	* 10.9	200	125	* 12.3	300	175
8.1	250	150	9.4	300	175	* 10.9	250	150	* 12.4	200	125
8.1	300	175	9.5	200	125	* 10.9	300	175	* 12.4	250	150
* 8.2	150	90	9.5	250	150	11.0	200	125	* 12.4	300	175
8.2	200	125	9.5	300	175	11.0	250	150	12.5	200	125
8.2	250	150	9.6	200	125	11.0	300	175	12.5	250	150
8.2	300	175	9.6	250	150	* 11.1	200	125	12.5	300	175
* 8.3	150	90	9.6	300	175	* 11.1	250	150	* 12.6	200	125
8.3	200	125	9.7	200	125	* 11.1	300	175	* 12.6	250	150
8.3	250	150	9.7	250	150	* 11.2	200	125	* 12.6	300	175
8.3	300	175	9.7	300	175	* 11.2	250	150	* 12.7	200	125
* 8.4	150	90	9.8	200	125	* 11.2	300	175	* 12.7	250	150
8.4	200	125	9.8	250	150	* 11.3	200	125	* 12.7	300	175
8.4	250	150	9.8	300	175	* 11.3	250	150	* 12.8	200	127
8.4	300	175	9.9	200	125	* 11.3	300	175	* 12.8	250	150
* 8.5	150	90	9.9	250	150	* 11.4	200	125	* 12.8	300	175
8.5	200	125	9.9	300	175	* 11.4	250	150	* 12.9	200	125
8.5	250	150	10.0	200	125	* 11.4	300	175	* 12.9	250	150
8.5	300	175	10.0	250	150	11.5	200	125	* 12.9	300	175
8.6	200	125	10.0	300	175	11.5	250	150	13.0	200	125
8.6	250	150	* 10.1	200	125	11.5	300	175	13.0	250	150
8.6	300	175	* 10.1	250	150	* 11.6	200	125	13.0	300	175
8.7	200	125	* 10.1	300	175	* 11.6	250	150			
8.7	250	150	* 10.2	200	125	* 11.6	300	175			
8.7	300	175	* 10.2	250	150	* 11.7	200	125			

超鈷鋼鑽頭系列  
SUPER COBALT STEEL DRILL BIT SERIES

## TD 斜柄鑽頭 Taper Shank

材料：HSS  
先端角：118°

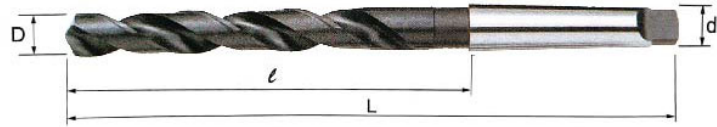

直徑 D	溝長 $l$	全長 L	M.T. NO.
7.5	78	158	1
8.0	82	162	1
8.5	85	168	1
9.0	88	172	1
9.5	92	175	1
10.0	95	178	1
10.5	98	172	1
11.0	102	185	1
11.5	105	188	1
12.0	108	192	1
12.5	112	195	1
13.0	115	198	1
13.5	118	202	1
14.0	122	205	1
14.5	122	222	2
15.0	125	225	2
15.5	128	228	2
16.0	130	230	2
16.5	132	232	2
17.0	135	235	2
17.5	140	240	2
18.0	140	240	2
18.5	145	245	2
19.0	145	245	2
19.5	150	250	2
20.2	150	250	2
20.5	155	255	2
21.0	155	255	2
21.5	160	260	2
22.0	160	260	2
22.5	165	265	2
23.0	165	265	2
23.5	165	285	3
24.0	165	285	3

直徑 D	溝長 $l$	全長 L	M.T. NO.
24.5	165	285	3
25.0	165	285	3
25.5	165	285	3
26.0	165	285	3
26.5	170	290	3
27.0	170	290	3
27.5	175	295	3
28.0	175	295	3
28.5	180	300	3
29.0	180	300	3
29.5	185	305	3
30.0	185	305	3
30.5	190	310	3
31.0	190	310	3
31.5	195	315	3
32.0	195	315	3
33.0	200	345	4
34.0	205	350	4
35.0	205	350	4
36.0	210	355	4
37.0	210	355	4
38.0	215	360	4
39.0	215	360	4
40.0	220	365	4
41.0	220	365	4
42.0	225	370	4
43.0	225	370	4
44.0	230	375	4
45.0	230	375	4
46.0	235	380	4
47.0	235	380	4
48.0	240	385	4
49.0	240	385	4
50.0	245	390	4

### ● 鎢鋼直柄機械絞刀

適用於加工一般鋼料、模具鋼、合金鋼、鑄鐵、鋁合金和非鐵金屬等材料。

螺旋角：7°

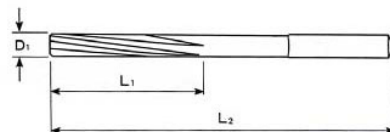

刀徑 D1	刃長 L1	全長 L2	刃數 N
1.0	5.5	36	4
1.1	6.5	36	4
1.2	7.5	36	4
1.3	7.5	36	4
1.4	8	43	4
1.5	8	43	4
1.6	9	43	4
1.7	9	43	4
1.8	10	46	4
1.9	10	46	4
2.0	14	49	4
2.1	14	49	4
2.2	14	57	4
2.3	14	57	4
2.4	14	57	4
2.5	14	57	4
2.6	14	57	4
2.7	15	61	4
2.8	15	61	4
2.9	15	61	4

m/m

刀徑 D1	刃長 L1	全長 L2	刃數 N
3.0	15	61	4
3.1	16	65	4
3.2	16	65	4
3.3	16	65	4
3.4	18	70	4
3.5	18	70	4
3.6	18	70	4
3.7	18	70	4
3.8	18	70	4
3.9	19	75	4
4.0	19	75	4
4.1	19	75	4
4.2	19	75	4
4.3	21	80	4
4.4	21	80	4
4.5	21	80	4
4.6	21	80	4
4.7	21	80	4
4.8	23	86	4

m/m

刀徑 D1	刃長 L1	全長 L2	刃數 N
4.9	23	86	6
5.0	23	86	6
5.1	23	86	6
5.2	23	86	6
5.3	23	86	6
5.4	26	93	6
5.5	26	93	6
5.6	26	93	6
5.7	26	93	6
5.8	26	93	6
5.9	26	93	6
6.0	26	93	6
6.1	28	101	6
6.2	28	101	6
6.3	28	101	6
6.4	28	101	6
6.5	28	101	6
6.6	28	101	6
6.7	28	101	6

m/m

刀徑 D1	刃長 L1	全長 L2	刃數 N
6.8	31	109	6
6.9	31	109	6
7.0	31	109	6
7.1	31	109	6
7.2	31	109	6
7.3	31	109	6
7.4	31	109	6
7.5	31	109	6
7.6	31	109	6
7.7	33	117	6
7.8	33	117	6
7.9	33	117	6
8.0	33	117	6
8.1	33	117	6
8.2	33	117	6
8.3	33	117	6
8.4	33	117	6
8.5	33	117	6
8.6	33	117	6

m/m

刀徑 D1	刃長 L1	全長 L2	刃數 N
8.7	36	125	6
8.8	36	125	6
8.9	36	125	6
9.0	36	125	6
9.1	36	125	6
9.2	36	125	6
9.3	36	125	6
9.4	36	125	6
9.5	36	125	6
9.6	36	125	6
9.7	38	133	6
9.8	38	133	6
9.9	38	133	6
10.0	38	133	6
10.1	38	133	6
10.2	38	133	6
10.3	38	133	6
10.4	38	133	6
10.5	38	133	6

m/m

刀徑 D1	刃長 L1	全長 L2	刃數 N
10.6	38	133	6
10.7	44	142	6
10.8	44	142	6
10.9	44	142	6
11.0	44	142	6
11.1	44	142	6
11.2	44	142	6
11.3	44	142	6
11.4	44	142	6
11.5	44	142	6
11.6	44	142	6
11.7	44	142	6
11.8	44	142	6
11.9	44	151	6
12.0	44	151	6
12.5	44	151	6
12.7	44	151	6
12.8	44	151	6
13.0	44	151	6

m/m

鎢鋼直柄機械絞刀 SUPER COBALT STEEL REAMER SERIES



● **MHSS-E 直柄機械絞刀** 倒角 $\varnothing 3.75$ 以下：15° /  $\varnothing 3.75$ 超過：45°

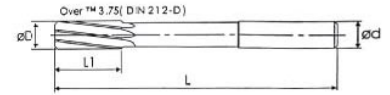

刀徑 $\varnothing D$	柄徑 $\varnothing d$	刃長 $L_1$	全長 $L$	刃數 $N$
2.0	2	11	49	4
2.5	2.5	14	57	4
3.0	3	15	61	6
3.5	3.5	18	70	6
4.0	4	19	75	6
4.5	4/4.5	21	80	6
5.0	5	23	86	6
5.5	5/5.6	26	93	6
6.0	5.6/6	26	93	6
6.5	6/6.3	28	101	6
7.0	6/7.1	31	109	6
7.5	6/7.1	31	109	6
8.0	8	33	117	6
8.5	8	33	117	6
9.0	8/9	36	125	6
9.5	8/9	36	125	6
10.0	10	38	133	6
10.5	10	38	133	6
11.0	10	41	142	6
12.0	10	44	151	6
13.0	10	44	151	6
14.0	12/12.5	47	160	8
15.0	12/12.5	50	162	8
16.0	12/12.5	52	170	8
17.0	12/14	54	175	8
18.0	12/14	56	182	8
19.0	16	58	189	8
20.2	16	60	195	8

超鈷鋼絞刀系列  
SUPER COBALT STEEL REAMER SERIES

● HSSCo8 90° 單刃倒角刀

適用於木頭和硬塑料，可在薄板上鑽孔，容易再研磨，加工時不會震動。

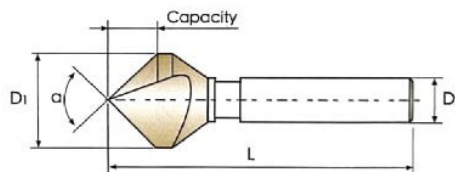
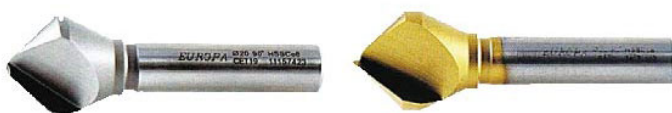

刀徑	刀長	柄徑	全長
10	1-10	6	45
10	1-1	10	60
15	2-15	8	55
15	2-15	10	60
20	2-20	10	65
25	3-25	10	78
25	3-25	12	78
30	3-30	12	88
35	4-35	16	110
40	5-40	12	115
40	5-40	16	115
45	10-45	16	120
50	12-50	16	130

● HSSCo8 90° 三刃倒角刀

自定心(3刃)，為90° 螺帽釘做埋頭孔而設計，手用，縱向倒角和作等值線，加工時不會震動。

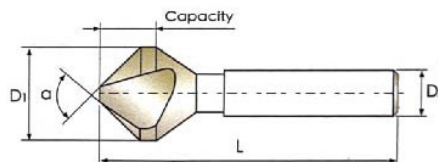
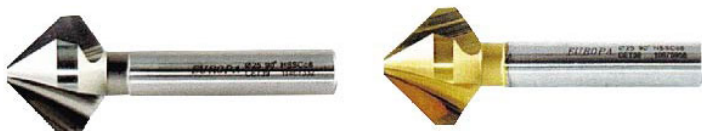

刀徑	刀長	柄徑	全長
6.3	1.5-6.3	5	45
8.0	2-8	6	50
10.0	2.5-10	6	50
12.4	2.8-12.4	8	56
15.0	3.2-15	10	60
16.5	3.2-16.5	10	60
20.5	3.5-20.5	10	63
25.0	3.8-25	10	67
30.0	4.2-30	12	71
31.0	4.2-31	12	71
35.0	4.5-30	16	110
40.0	4.5-40	12	115
40.0	4.5-40	16	115
45.0	5.0-45	16	120
50.0	5.0-50	16	130

## ● 刀具車/刀具架

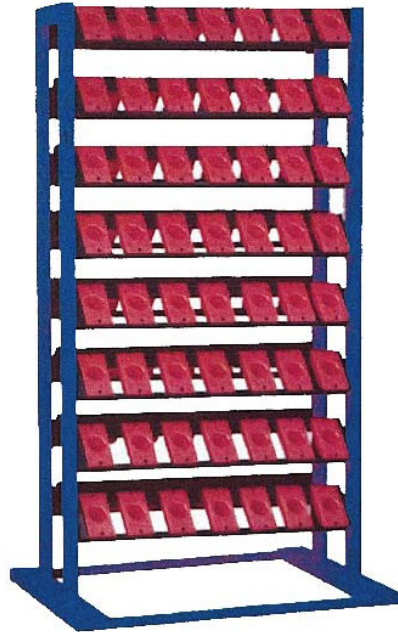
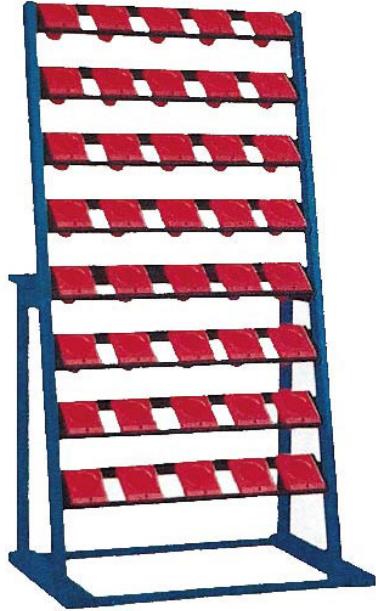

訂購編號	品 號	刀座量
N06-001	單面刀具架STR-40	56支
N06-002	單面刀具架STR-50	40支
N06-003	雙面刀具架TTR-40	112支
N06-004	雙面刀具架TTR-50	80支



訂購編號	品 號	刀套(數量)
N06-005	BT-30刀具車	32
N06-006	BT-40刀具車	28
N06-007	BT-50刀具車	20
N06-008	HSK-40刀具車	28
N06-009	HSK-50刀具車	28
N06-010	HSK-60刀具車	24

● AMS-160AH  
強力型工件定位器



產品特色

1. 固定於工作台T型槽上，移動容易。
2. 可調整高低與方向。
3. 結構堅固耐用，使用壽命長。

規格

AMS-160AH

● AMS-160BH  
工件定位器



產品特色

1. 可重疊使用，做多點定位。
2. 可任意變化高低與方向操作簡易。

規格

AMS-160BH

● P2 磨刀器

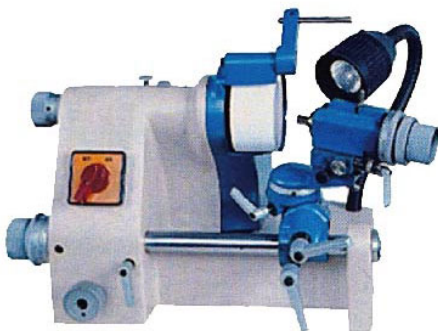

品號	品名規格
N33-001	P2-銼刀研磨機
N45-002	鑽石砂輪/200#
	鑽石砂輪(訂製品)

● 工業用吸塵器



品號	品名規格	馬力	容量
N37-001	工業用吸塵·吸水機	2.5HP	10加侖
N37-002	工業用吸塵·吸水機	5.0HP	15加侖

## ● MC定壓式倍力虎鉗 / MC精密機械式虎鉗

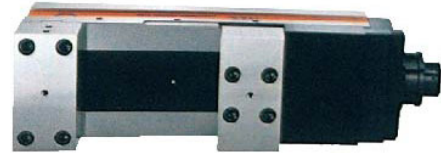

虎鉗可側立使用

MODEL	夾持力(刻度) Clamping(Scale)					開口範圍
	1	2	3	4	5	Clamping Range
JQV-125	Direct	1000	2200	3500		0~230
JQV-160S	Direct	2000	3000	4000	5000	0~235
JQV-160M	Direct	2000	3000	4000	5000	0~275
JQV-160	Direct	2000	3000	4000	5000	0~305
JQV-160L	Direct	2000	3000	4000	5000	0~355
JQV-200L	Direct	2000	3500	4500	6000	0~405

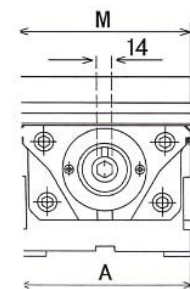
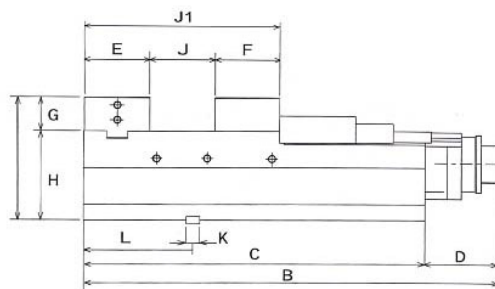
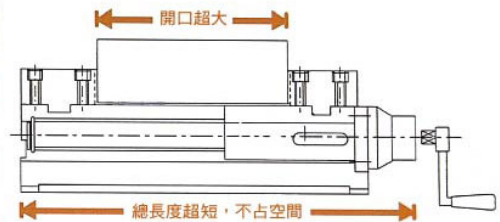

MC定壓式倍力虎鉗

品 號	A	B	C	D	E	F	G	H	I	J	J1	K	L	M	夾持力	N.W
JQV-125	125	497	398	99	84	76	50	85	135	230	388	18	144	125	3500kgf	36kg
JQV-160S	161	515	416	99	86	86	50	105	155	235	405	18	144	159	5000kgf	55kg
JQV-160M	161	555	456	99	86	86	50	105	155	275	445	18	144	159	5000kgf	57kg
JQV-160	161	585	486	99	86	86	50	105	155	305	475	18	144	159	5000kgf	60kg
JQV-160L	161	635	536	99	94	86	60	100	160	355	533	18	152	159	5000kgf	66kg
JQV-200L	201	710	610	99	102	98	70	110	180	405	603	18	176	199	6000kgf	103kg

MC精密機械式虎鉗

品 號	A	B	C	D	E	F	G	H	I	J	J1	K	L	M	N.W
JQV-125	125	497	398	99	84	76	50	85	135	230	388	18	144	125	39kg
JQV-160S	161	515	416	99	86	86	50	105	155	235	405	18	144	159	53kg
JQV-160M	161	555	456	99	86	86	50	105	155	275	445	18	144	159	55kg
JQV-160	161	585	486	99	86	86	50	105	155	305	475	18	144	159	58kg
JQV-160L	161	635	536	99	94	86	60	100	160	355	533	18	152	159	64kg
JQV-200L	201	710	610	99	102	98	70	110	180	405	603	18	176	199	102kg

● MC定壓式倍力虎鉗 / MC精密機械式虎鉗



虎鉗可側立使用

產品特色

- 1.角固式配合"半圓球體"下鎖之力，可防止工件箭上浮。
- 2.增壓式與機械式兩種使用方法。
- 3.虎鉗本台採用球狀石墨化鑄鐵FCD-60材質。
- 4.虎鉗滑動面均經硬化熱處理HRC45°，堅固耐用確保精度。
- 5.虎鉗本體的高度與導正鍵槽皆做定寸管制，可以2、3、4台一起使用
- 6.虎鉗有四種不同的夾持方式，供您選擇。

每台虎鉗的高度與導正鍵槽皆做定寸管制。

L-尺寸公差限度0.02少於

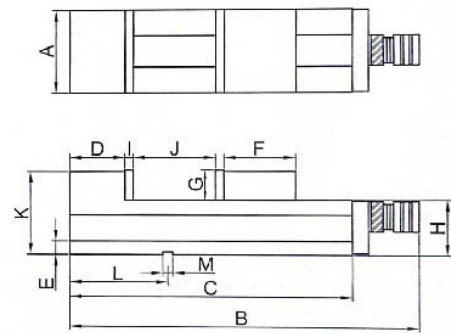
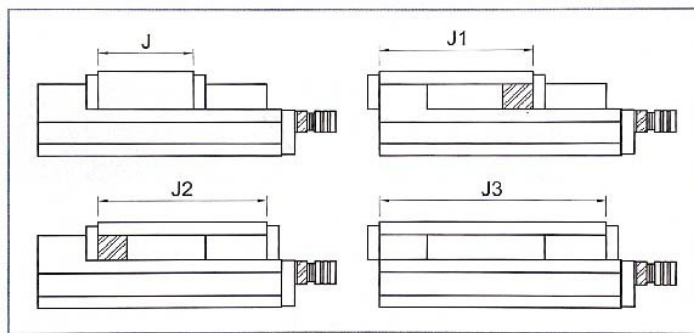
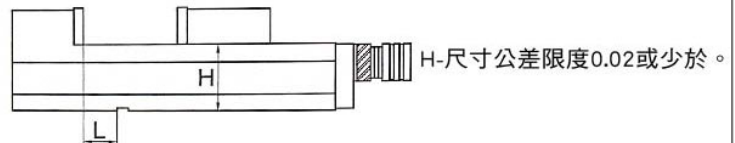

虎鉗有四種不同的夾持方式，供您選擇。

品號	A	B	C	D	E	F	G	H	I	J	J1	J2	J3	K	L	M	N.W	夾持力
MPV-130	132	558	423	70	25	110	54	95	15	200	200-260	200-300	200-410	147	165	18	38kg	4400kgf
MPV-160	162	632	497	85	25	130	57	105	15	240	240-315	240-360	240-470	160	165	18	59kg	5000kgf
MPV-160A	162	692	557	85	25	130	57	105	15	300	300-375	300-420	300-530	160	165	18	65kg	5000kgf
MPV-200	202	710	570	90	25	139	62	110	18	300	300-375	300-425	300-560	170	190	18	80kg	5000kgf



● MC機械式角固虎鉗

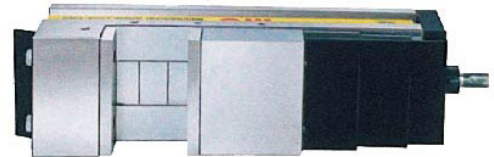

虎鉗可側立使用

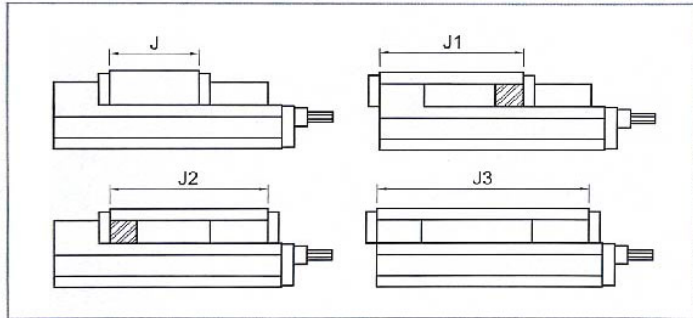

虎鉗有四種不同的夾持方式，供您選擇。

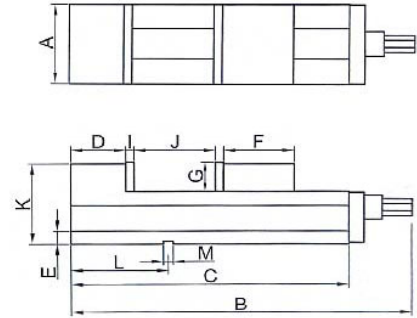

品 號	A	B	C	D	E	F	G	H	I	J	J1	J2	J3	K	L	M	N.W
MV-100	102	435	340	65	25	102	47	85	15	125	125-190	125-230	125-320	130	125	16	25kg
MV-130	132	518	423	70	25	110	54	95	15	200	200-260	200-300	200-410	147	165	18	38kg
MV-160	162	592	497	85	25	130	57	105	15	240	240-315	240-360	240-470	160	165	18	59kg
MV-160A	162	652	559	85	25	130	57	105	15	300	300-375	300-420	300-530	160	165	18	65kg
MV-200	202	670	570	90	25	139	62	110	18	300	300-375	300-425	300-560	170	190	18	80kg

● MC直立式2.4台增壓角固虎鉗

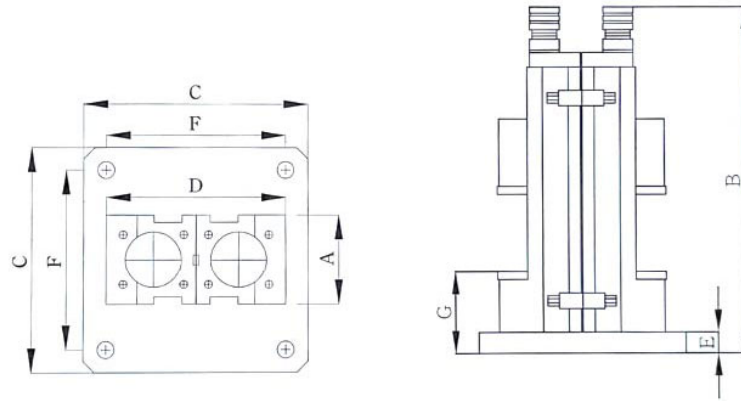

品 號	A	B	C	D	E	F	G	N.W
MHV-100-2V	102	515	300	266	40	200	134	79kg
MHV-100-4V	102	515	400	266	40	320	134	151kg
MHV-130-2V	132	598	300	294	40	200	152	105kg
MHV-130-4V	132	598	400	294	40	620	152	203kg
MHV-160-2V	162	672	400	320	40	320	156.5	169kg
MHV-160-4V	162	672	500	320	40	400	156.5	315kg
MHV-200-2V	202	755	400	340	40	320	169	211kg
MHV-200-4V	202	755	500	340	40	400	169	399kg

● MC直立式4台增壓角固虎鉗附治具桶

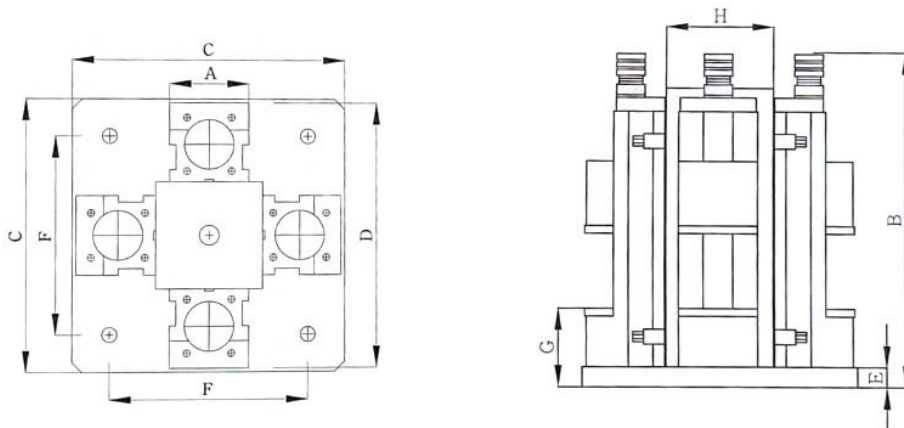

品 號	A	B	C	D	E	F	G	H	N.W
MHV-100-4VB	102	515	450	416	40	320	134	150	200kg
MHV-130-4VB	132	598	500	474	40	320	152	180	300kg
MHV-160-4VB	162	672	550	530	40	400	156.5	210	440kg
MHV-200-4VB	202	755	600	590	45	500	174	250	560kg

## ● MC內藏式增壓角固虎鉗



虎鉗可側立使用

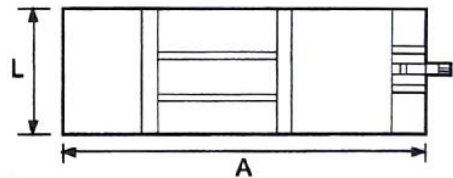
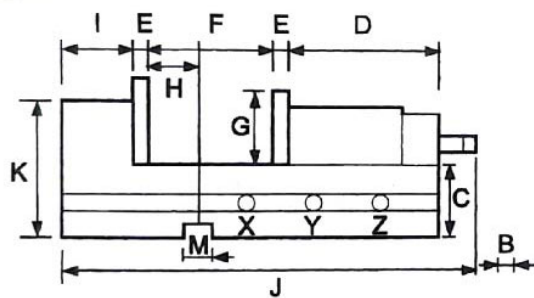

品 號	A	B	C	D	E	夾持範圍			G	H	I	J	K	L	M	F	kgf	kg
						X	Y	Z										
MHA-100	404	14	62	208	12.5	0-85	85-170		42	45	64.5	450 540	102	105	16	50	2500	22
MHA-150	507	19	85	243	15.5	0-90	90-180	180-270	57	65	84.5	620 710	140	152	18	90	5000	50
MHA-150A	537	19	85	243	15.5	0-100	100-200	200-300	57	65	84.5	650 740	140	152	18	90	5000	52
MHA-200	606	19	95	257	18.5	0-100	100-200	200-300	62	82	89.5	655 755	162	200	18	150	7000	80

## ● 內藏式增壓角固虎鉗

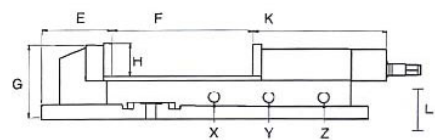
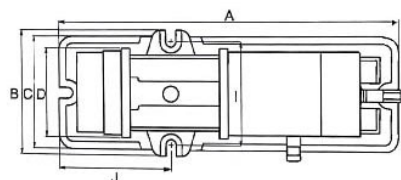

品 號	A	B	C	D	E	F	G	H	I	J	K	L	X	Y	Z	PRESSURE	N.W.
HA-150	618	226	204	150	134	0-300	140	57	186	209	252	83	0-100	100-200	200-300	4500kgf	55kg
HA-200	695	278	230	200	148	0-300	157	64	237	260	270	102	0-100	100-200	200-300	8000kgf	92kg

● 內藏式增壓虎鉗

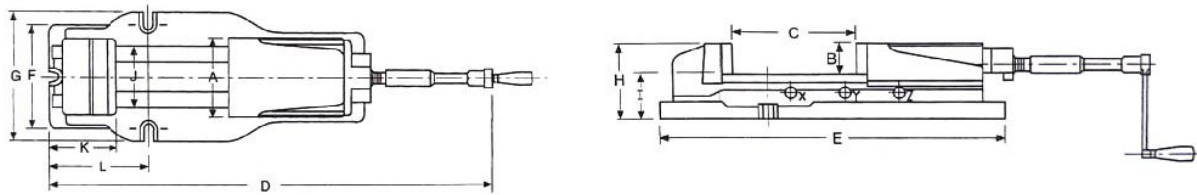

品 號	A	B	C	D	E	F	G	H	I	J	K	L	夾持範圍			kgf	kg	
													X	Y	Z		Table	Disk Rotary
HV-100	105	36	170	525	440	135	170	95	58	80	95	147	0-57	55-114	112-170	2500	21	7
HV-130	130	48	220	670	550	175	207	120	70.5	97	107	195	0-73	72-146	145-220	3500	38	8
HV-150	150	53	300	970	620	182	225	135	82.5	116	117	210	0-100	98-200	198-300	4500	53	11
HV-200	200	62	300	900	680	260	280	162	100	160	150	260	0-100	99-200	198-300	8000	95	13

● 傾斜式增壓虎鉗

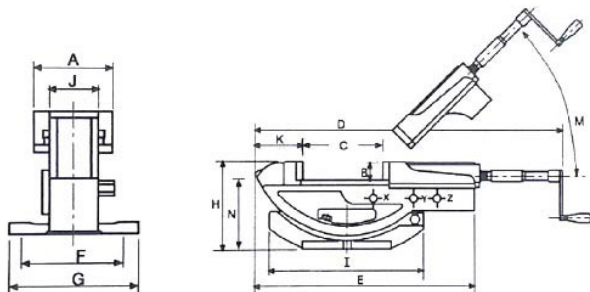
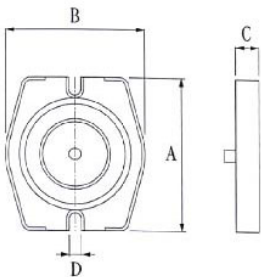
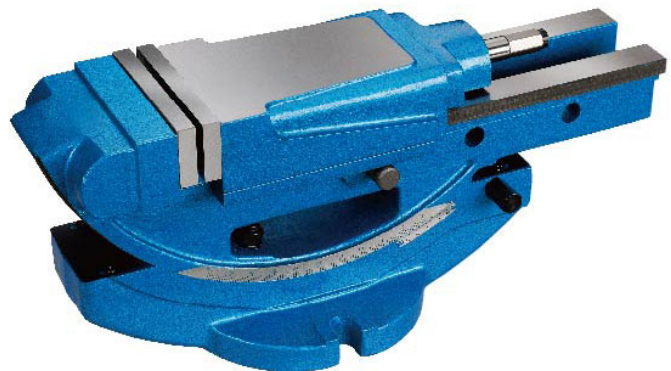

SWIVEL BASE 迴轉底盤

ORDER NO.	A	B	C	D	G.W(kg)
HS-4	270	240	40.7	15	7
HS-5	292	267	44	17	8
HS-6	330	300	40.8	17	11
HS-8	380	345	42.2	19	13

品 號	A	B	C	D	E	F	G	H	I	J	K	M	N	kgf	Weight(kg)	
THV-100	105	36	0-170	547	420	106	165	191	340	80	92	0°~45°	160	2500	body 26kg	Swivel base 7kg
THV-150	150	53	0-300	790	600	165	230	250	435	116	123	0°~45°	197	4500	body 70kg	Swivel base 11kg

## ● MC精密型空油壓式角固虎鉗

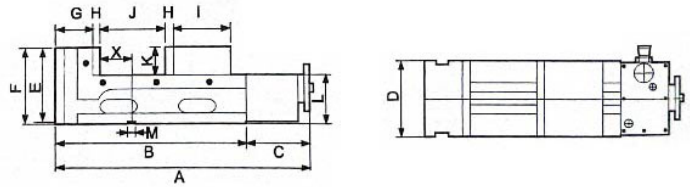
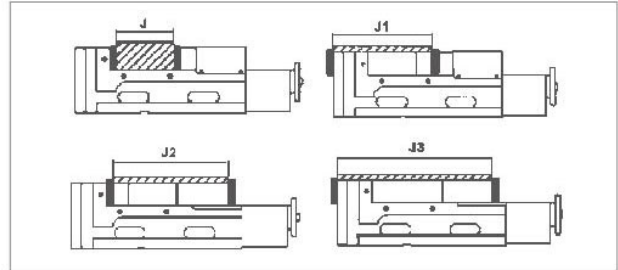
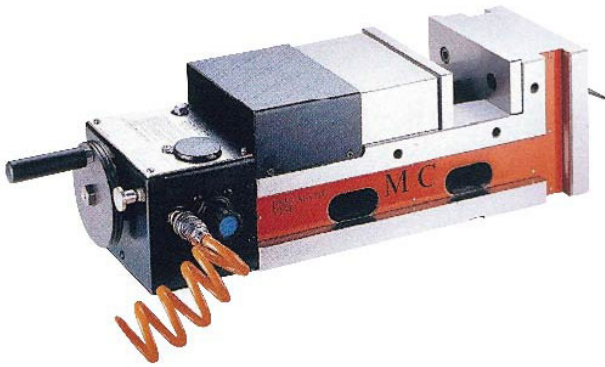

Model	A	B	C	D	E	F	G	H	I	J	J1	J2	J3	K	L	M	X	kgf	N.W. (kg)	G.W. (kg)
JPV-4"-100	435	320	140	100	145	148	85	15	100	0-100	95-220	100-200	200-300	48	100	16	45	3200	27	29
JPV-5"-150	520	380	140	130	157	160	85	15	110	0-150	95-250	110-275	200-380	55	105	18	45	6000	38	40
JPV-6"-160	540	400	140	160	157	160	87	15	120	0-160	95-260	120-295	210-400	55	105	18	45	6000	48	50
JPV-6"-250	630	490	140	160	157	160	87	15	120	0-250	95-350	120-395	210-490	55	105	18	45	6000	54	56
JPV-7"-200	580	440	140	180	170	173	90	18	130	0-200	100-290	130-330	220-440	63	110	18	72	9000	65	72
JPV-8"-200	610	470	140	200	170	173	90	18	140	0-200	100-310	140-360	230-470	63	110	18	72	9000	70	80
JPV-8"-300	710	570	140	200	170	173	90	18	140	0-300	100-410	140-460	230-570	63	110	18	72	9000	79	90

## ● 精密型角固虎鉗

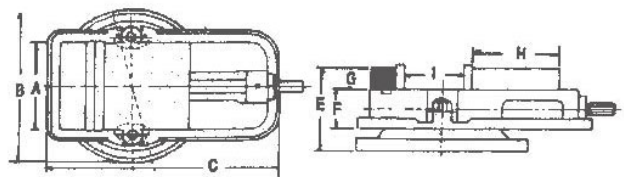
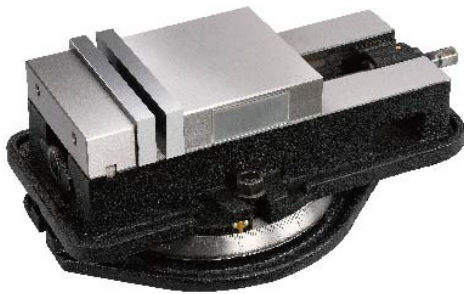

MODEL	A	B	C	E	F	G	H	I	Weight(kg)
AV-4"	100	220	320	133	65	38	115	105	19
AV-5"	125	240	360	146	70	38	132	120	29
AV-6"	150	290	430	161	72	48	170	150	48
AV-6"開8"	150	310	405	155	72	40	125	198	50
AV-8"	200	370	548	191	85	55	190	200	90

<http://www.msc-hsc.com.tw>



精密切削工具 / 訂製鎢鋼刀具 / 超細微粒鎢鋼  
超硬鎢鋼刀具 / 焊刀鎢鋼刀具 / 精捨棄式刀具

**明勝創精密刀具有限公司**  
MING SHENG CHUANG PRECISION TOOL CO., LTD.

TEL:886-4-2515-6305 FAX:886-4-2515-0159

台中市豐原區豐勢路一段475號

No. 475, Sec. 1, Fengshi Rd., Fengyuan Dist., Taichung City 420, Taiwan (R.O.C.)

<http://www.msc-hsc.com.tw> E-mail:[msc.hsc@msa.hinet.net](mailto:msc.hsc@msa.hinet.net)